



XL TELECOM LIMITED

[Registration Number 01-5844]

[The Company was originally incorporated as a Private Limited company under the provisions of the Companies Act, 1956 on October 3, 1985 under the name and style of "XL Cable Splices Private Limited" with The Registrar of Companies, Andhra Pradesh at Hyderabad and subsequently the name of the company was changed to "XL Telecom Private Limited" on December 18, 1985. Later, by virtue of Special Resolution passed on October 29, 1990, the Company was converted into a Public Limited Company. Consequent on its conversion, The Registrar of Companies, Andhra Pradesh, Hyderabad has issued a fresh certificate of incorporation dated December 31, 1990.]

Registered Office: 335, Chandralok Complex, Sarojini Devi Road, Secunderabad – 500 003

(On incorporation the Registered Office was located at A1/3, Chandralok Complex, Sarojini Devi Road, Secunderabad – 500 003, Andhra Pradesh and was shifted to 335, Chandralok Complex, Sarojini Devi Road, Secunderabad – 500 003 w.e.f. May 18, 1987)

Tel.: +91 40 2784 9094, 2784 0109, 2784 7287 **Fax:** +91 40 2784 0081

Website: www.xltelecom.net; **Contact Person:** Ch. Bhavani; **Email:** chbhavani@xltelecom.net

PUBLIC ISSUE OF 39,56,808 EQUITY SHARES OF RS. 10/- EACH FOR CASH AT A PRICE OF RS. [●]/- PER EQUITY SHARE AGGREGATING TO RS. [●]/- LAKHS (HEREINAFTER REFERRED TO AS "THE ISSUE") BY XL TELECOM LIMITED ("THE COMPANY" OR "THE ISSUER"). THE FACE VALUE OF THE EQUITY SHARES IS RS. 10/- EACH. THE ISSUE INCLUDES A RESERVATION OF 1,76,808 EQUITY SHARES OF RS. 10/- EACH AGGREGATING TO RS. [●]/- LAKHS FOR SUBSCRIPTION BY ELIGIBLE EMPLOYEES OF THE COMPANY. THE NET ISSUE TO THE PUBLIC SHALL BE OF 37,80,000 EQUITY SHARES OF RS. 10/- EACH AGGREGATING TO RS. [●]/- LAKHS. THE NET ISSUE WOULD CONSTITUTE 26.07% OF THE POST ISSUE PAID UP CAPITAL OF THE COMPANY.

PRICE BAND: Rs. 125 TO Rs. 150 PER EQUITY SHARE OF FACE VALUE Rs. 10/- EACH.

THE ISSUE PRICE IS 12.50 TIMES THE FACE VALUE AT THE FLOOR PRICE OF THE PRICE BAND AND 15 TIMES THE FACE VALUE AT THE CAP PRICE OF THE PRICE BAND.

In case of revision in the Price Band, the Bidding/ Issue Period will be extended for three additional working days after revision of the Price Band subject to the Bidding/ Issue Period not exceeding 10 working days. Any revision in the Price Band and the revised Bidding/ Issue Period, if applicable, will be widely disseminated by notification to the Bombay Stock Exchange Limited ("BSE") and National Stock Exchange of India Limited ("NSE") and by issuing a press release and also by indicating the change on the website of the Book Running Lead Managers and at the terminals of the Members of the Syndicate.

The Issue is being made through a 100% Book Building Process wherein up to 50% of the Net Issue to the public shall be allocated on a proportionate basis to Qualified Institutional Buyers (QIBs), out of which 5% of the QIB Portion shall be available for allocation on a proportionate basis to Mutual Funds only and the remaining QIB Portion shall be available for allocation on a proportionate basis to all QIBs, including Mutual Funds, subject to valid Bids being received at or above Issue price. Further, atleast 15% of the Net Issue to the public shall be available for allocation on a proportionate basis to Non-Institutional Bidders and atleast 35% of the Net Issue to the public shall be available for allocation on a proportionate basis to Retail Individual Bidders, subject to valid Bids being received at or above the Issue Price.

RISK IN RELATION TO FIRST ISSUE

This being the first issue of Equity Shares of the Company, there has been no formal market for its Equity Shares. The face value of the shares is Rs. 10/- and the issue price is [●] times of the face value. The Issue Price (as determined by the Company in consultation with the Book Running Lead Manager, on the basis of assessment of market demand for the Equity Shares by way of Book Building) should not be taken to be indicative of the market price of the Equity Shares after the Equity Shares are listed. No assurance can be given regarding an active and/or sustained trading in the Equity Shares of the Company or regarding the price at which the Equity Shares will be traded after listing.

GENERAL RISK

Investments in equity and equity related securities involve a degree of risk and investors should not invest any funds in this Issue unless they can afford to take the risk of losing their investment. Investors are advised to read the risk factors carefully before taking an investment decision in this Issue. For taking an investment decision, investors must rely on their own examination of the Company and the Issue including the risks involved. The Equity Shares offered in the Issue have not been recommended or approved by the Securities and Exchange Board of India ("SEBI"), nor does SEBI guarantee the accuracy or adequacy of this Red Herring Prospectus.

The attention of the investors is drawn to the 'Risk Factors and Management Perceptions thereof' appearing on page ix of this Red Herring Prospectus.

IPO GRADING

The Company has not opted for IPO Grading.

ISSUER'S ABSOLUTE RESPONSIBILITY

The Company having made all reasonable inquiries, accepts responsibility for and confirms that this Red Herring Prospectus contains all information with regard to the Company and the Issue, which is material in the context of the Issue, that the information contained in this Red Herring Prospectus is true and correct in all material aspects and is not misleading in any material respect, that the opinions and intentions expressed herein are honestly held and that there are no other facts, the omission of which makes this Red Herring Prospectus as a whole or any of such information or the expression of any such opinions or intentions misleading in any material respect.

LISTING

The Equity Shares issued through this Red Herring Prospectus are proposed to be listed on Bombay Stock Exchange Limited (BSE) (the Designated Stock Exchange) and The National Stock Exchange of India Limited (NSE). The Company has received the in-principle approvals from BSE pursuant its letter dated July 3, 2006 and from NSE pursuant to its letter dated July 24, 2006 and November 3, 2006.

BOOK RUNNING LEAD MANAGERS		REGISTRAR TO THE ISSUE
 ANAND RATHI SECURITIES LIMITED J.K. Somani Building, 3 rd Floor, British Hotel Lane, Bombay Samachar Marg, Fort, Mumbai – 400 023 Tel: +91 22 6637 7000 Fax: +91 22 6637 7070 Email: xtlf@rathi.com Website: www.rathi.com Contact Person: Mr. Paresh Raja	 CENTRUM CAPITAL LIMITED 5 th Floor, Khetan Bhavan, 198, J Tata Road, Churchgate, Mumbai – 400 020 Tel: +91 22 3028 0400 Fax: +91 22 2204 6096 Email: xltelecom@centrum.co.in Website: www.centrum.co.in Contact Person: Mr. Mayank Dalal	 BIGSHARE SERVICES PVT. LTD. E/2, Ansa Industrial Estate, Saki Vihar Road, Saki Naka, Andheri (E), Mumbai – 400 072. Tel: +91 22 2847 3747 Fax: +91 22 2847 5207 E-mail: bigshare@bom7.vsnl.net.in Website: www.bigshareonline.com Contact Person: Mr. N.V.K. Mohan

ISSUE SCHEDULE

BID / ISSUE OPENS ON: MONDAY, DECEMBER 4, 2006

BID / ISSUE CLOSURES ON: THURSDAY, DECEMBER 7, 2006

TABLE OF CONTENTS

I.	DEFINITIONS AND ABBREVIATIONS	i
II.	RISK FACTORS AND MANAGEMENT PERCEPTIONS THEREOF	ix
	1. Forward-Looking Statements	x
	2. Risk Factors	xi
III.	INTRODUCTION	1
	1. Summary of the Industry and Business	1
	2. General Information	8
	3. Capital Structure	15
	4. Objects of the Issue	22
	5. Basic Terms of the Issue	29
	6. Basis for Issue Price	31
	7. Statement of Tax Benefits	34
IV.	ABOUT THE COMPANY	40
	1. Industry Overview	40
	2. Business Overview	44
	3. Key Industry Regulations & Policies	65
	4. History and Corporate Structure	66
	5. Our Management	70
	6. Our Promoters	81
V.	FINANCIAL INFORMATION	85
	1. Financial Information of the Company	85
	2. Financial Information of the Group Companies	101
	3. Management's Discussion and Analysis of Financial Condition and Result of Operations	102
VI.	LEGAL AND OTHER INFORMATION	111
	1. Outstanding Litigations and Material Developments	111
	2. Government Approvals / Licensing Arrangements	114
VII.	OTHER REGULATORY AND STATUTORY DISCLOSURES	118
VIII.	ISSUE RELATED INFORMATION	124
IX.	ISSUE STRUCTURE	127
X.	ISSUE PROCEDURE	129
XI.	MAIN PROVISIONS OF THE ARTICLES OF ASSOCIATION	151
XII.	MATERIAL CONTRACTS AND DOCUMENTS	167
	1. Material Contracts for Inspection	167
	2. Material Documents for Inspection	167
	3. Declaration	169



SECTION: I: DEFINITIONS AND ABBREVIATIONS

I. CONVENTIONAL / GENERAL TERMS:

TERM	DESCRIPTION
Articles / Articles of Association / AoA	Articles of Association of the Company
Companies Act	The Companies Act, 1956, as amended from time to time for the time being in force
Depository	A depository registered with SEBI under the SEBI (Depositories and Participant) Regulations, 1996, as amended from time to time.
Depositories Act	The Depositories Act, 1996, as amended from time to time for the time being in force
Depository Participant	A depository participant as defined under the Depositories Act
FEMA	Foreign Exchange Management Act, 1999, as amended from time to time and the regulations framed there under for the time being in force
Financial Year/FY / Fiscal	Period of twelve months ended June 30 of that particular year
FIs	Financial Institutions
FII/ Foreign Institutional Investor	Foreign Institutional Investor (as defined under SEBI (Foreign Institutional Investors) Regulations, 1995) registered with SEBI under applicable laws in India
Indian GAAP	Generally Accepted Accounting Principles in India
IT Act	The Income-Tax Act, 1961, as amended from time to time and for the time being in force
Memorandum / Memorandum of Association / MoA	The Memorandum of Association of the Company
NRI / Non-Resident Indian	A person resident outside India, as defined under FEMA and who is a citizen of India or a Person of Indian Origin under FEMA (Transfer or Offer of Security by a Person Resident Outside India) Regulations, 2000.
OCB / Overseas Corporate Body	A company, partnership, society or other corporate body owned directly or indirectly to the extent of at least 60% by NRIs including overseas trusts, in which not less than 60% of beneficial interest is irrevocably held by NRIs directly or indirectly as defined under FEMA (Transfer or Issue of Security by a Person Resident Outside India) Regulations, 2000
Person / Persons	Any individual, sole proprietorship, unincorporated association, unincorporated organisation, body corporate, corporation, company, partnership, limited liability company, joint venture or trust or any other entity or organisation validly constituted and/ or incorporated in the jurisdiction in which it exists and operated / as the context required
POI/ Person of Indian Origin	Shall have the same meaning as is ascribed to such term in the Foreign Exchange Management (Investment in firm or Proprietary Concern in India) Regulations, 2000.
SCRR	Securities Contracts (Regulations) Rules, 1957 as amended from time to time
SEBI	The Securities and Exchange Board of India constituted under the SEBI Act
SEBI Act	Securities and Exchange Board of India Act, 1992, as amended from time to time and for the time being in force
SEBI Guidelines	SEBI (Disclosure and Investor Protection) Guidelines, 2000 issued by SEBI on January 27, 2000, as amended, including instructions and clarifications issued by SEBI from time to time
SEBI Insider Trading Regulations	The SEBI (Prohibition of Insider Trading) Regulations, 1992, as amended from time to time, including instructions and clarifications issued by SEBI from time to time.
SEBI Takeover Regulations	Securities and Exchange Board of India (Substantial Acquisition of Shares and Takeover) Regulations, 1997, as amended from time to time.
U.S. GAAP	Generally accepted accounting principles in the United States.



II. ISSUE-RELATED TERMS:

TERM	DESCRIPTION
Allotment / Allotment of Equity Shares	Unless the context otherwise requires, issue of equity shares pursuant to this Issue
Allottees	The successful applicant to whom the Equity Shares are being / or have been issued or transferred
Applicant	Any prospective investor who makes an application for Equity Shares in terms of this Red Herring Prospectus.
Application Form	The Form in terms of which the investors shall apply for the Equity Shares of the Company.
Banker(s) to this Issue	The Bank in which the Escrow Account for the Public Issue will be opened and which act as such, in terms of this Red Herring Prospectus.
Bid	An indication to make an offer, made during the Bidding Period by a prospective investor to subscribe to the Equity Shares at a price within the Price Band, including all revisions and modifications thereto.
Bid Amount	The highest value of the optional Bids indicated in the Bid-cum-Application Form and payable by the Bidder on submission of the Bid for this Issue.
Bid/ Issue Closing Date	The date after which the members of the Syndicate will not accept any Bids for this Issue, which shall be notified in a widely circulated English national newspaper, a Hindi national newspaper and a regional newspaper.
Bid/Issue Opening Date	The date on which the investors can apply for equity shares being offered under this issue, which shall be notified in a widely circulated English national newspaper, a Hindi national newspaper and a regional newspaper.
Bid-cum-Application Form	The form in terms of which the Bidder shall make an offer to subscribe to the Equity Shares of our Company and which will be considered as the application for allotment in terms of the Red Herring Prospectus.
Bidder	Any prospective investor who makes a Bid pursuant to the terms of the Red Herring Prospectus and the Bid-cum-Application Form.
Book Building Process	Book building mechanism as provided under Chapter XI of the SEBI Guidelines, in terms of which this Issue is made.
BRLMs / Book Running Lead Managers	Book Running Lead Managers to this Issue, in this case being Anand Rathi Securities Limited and Centrum Capital Limited
BSE	Bombay Stock Exchange Limited
CAGR	Compounded Annual Growth Rate
CAN/ Confirmation of Allocation Note	Means the note or advice or intimation of allocation of Equity Shares sent to the applicants who have been allocated Equity Shares in this Issue.
Cap Price	The upper end of the Price Band, above which the Issue Price will not be finalised and above which no Bids will be accepted.
CDSL	Central Depository Services (India) Limited
Cut-off Price	The Issue Price finalized by our Company in consultation with the BRLMs and it shall be any price within the Price Band. A Bid submitted at the Cut-off Price by a Retail Individual Bidder is a valid Bid at all price levels within the Price Band.
D/E Ratio	Debt-Equity Ratio
Designated Date	The date on which funds are transferred from the Escrow Account to the Public Issue Account after the Prospectus is filed with the RoC, following which the Board of Directors shall allot Equity Shares to successful Bidders.
Designated Stock Exchange	Designated Stock Exchange shall mean BSE



TERM	DESCRIPTION
DP	Depository Participant
Draft Red Herring Prospectus	Draft Red Herring Prospectus issued in accordance with Section 60B of the Companies Act, which does not have complete particulars on the price at which the Equity Shares are offered and size of this Issue. It will become a Red Herring Prospectus after filing with the Registrar of Companies, Andhra Pradesh at Hyderabad at least three days before the opening of this Issue. It will become a Prospectus after filing with the Registrar of Companies, Andhra Pradesh at Hyderabad, after the Pricing Date.
ECS	Electronic Clearing Services.
Eligible Employee/ Employees (in the Employee Reservation Portion)	All or any of the following: a) A permanent employee of our Company; b) A Director of our Company (whether a whole-time Director, part time Director or otherwise); and An Employee, as used in the context of the Employee Reservation Portion, should be an Indian national, based in India and physically present in India on the date of submission of the Bid-cum-Application Form. Also, such person should be an Employee on the payroll of the Company on the date of filing this Red Herring Prospectus with SEBI. Promoter Directors and / or their relatives are not permitted to participate in this Issue.
Employee Reservation Portion	The portion of this Issue being 1,76,808 Equity Shares of Rs. 10/- each available for allocation to Eligible Employees
Equity Shares	Equity shares of face value of Rs.10 each of the Company unless otherwise specified in the context thereof
Escrow Account	Account opened with Escrow Collection Bank(s) and in whose favor the Bidder will issue cheques or drafts in respect of the Bid Amount.
Escrow Agreement	Agreement to be entered into among our Company, the Registrar to this Issue, the Escrow Collection Banks and the BRLMs in relation to the collection of the Bid Amounts and dispatch of the refunds (if any) of the amounts collected, to the Bidders.
Escrow Collection Bank(s)	The banks, which are registered with SEBI as Banker (s) to this Issue at which the Escrow Account for this Issue will be opened.
ESOP	Employee Stock Option Plan
ESPS	Employee Stock Purchase Scheme
Face Value	Face Value of equity shares of the Company being Rs. 10/- each
FIPB	Foreign Investment Promotion Board, Ministry of Finance, Government of India
First Bidder	The Bidder whose name appears first in the Bid-cum-Application Form or Revision Form.
Floor Price	The lower end of the Price Band, below which this Issue Price will not be finalised and below which no Bids will be accepted.
GIR Number	General Index Registry Number
INR/ Rs	Indian National Rupee
IPO	Initial Public Offering
Issue Price	The final price at which Equity Shares will be issued and allotted in terms of the Red Herring Prospectus. The Issue Price will be decided by our Company in consultation with the BRLMs on the Pricing Date.
Issue/ Bidding Period	The period between the Bid / Issue Opening Date and the Bid/Issue Closing Date inclusive of both days and during which prospective Bidders can submit their Bids.
Issue/ Public Issue	Public issue of 39,56,808 Equity Shares of Rs. 10/- each at a Price of Rs. [●] per Equity Shares for cash aggregating Rs. [●] lakh pursuant to this Red Herring Prospectus.
Issuer/ Company / XL	XL Telecom Limited



TERM	DESCRIPTION
Lead Manager/ Lead Manager to the Issue / LM	Being the Lead Manager appointed for the Issue. In this case being Anand Rathi Securities Limited and Centrum Capital Limited
Margin Amount	The amount paid by the Bidder at the time of submission of the Bid, being 10% to 100% of the Bid Amount.
Mutual Funds	Means mutual funds registered with SEBI pursuant to the SEBI (Mutual Funds) Regulations, 1996, as amended from time to time.
Non Institutional Bidders	All Bidders that are not Qualified Institutional Buyers or Retail Individual Bidders and who have Bid for Equity Shares for an amount more than Rs. 100,000.
Non Institutional Portion	The portion of this Issue being at least 15% of the Net Issue to Public consisting of 5,67,000 Equity Shares of Rs. 10/- each, available for allocation to Non Institutional Bidders.
NSE	National Stock Exchange of India Limited
OCB	A Company, Partnership, society or other corporate body owned directly or indirectly to the extent of at least 60% by NRI, including overseas trusts, in which not less than 60% of the beneficial interest is irrevocably held by NRIs directly or indirectly as defined under FEMA (Transfer or issue of Securities by a Person Resident Outside India) Regulations, 2000. OCBs are not allowed to invest in this Issue.
PAN	Permanent Account Number
Pay-in Date	Bid/Issue Closing Date or the last date specified in the CAN sent to Bidders receiving allocation who pay less than 100% margin money at the time of bidding, as applicable.
Pay-in-Period	Means: (i) with respect to Bidders whose Margin Amount is 100% of the Bid Amount, the period commencing on the Bid/ Issue Opening Date and extending until the Bid/Issue Closing Date; and (ii) with respect to QIBs, whose Margin Amount is 10% of the Bid Amount, the period commencing on the Bid/Issue Opening Date and extending until the closure of the Pay in Date.
Price Band	The price band of a minimum price ("Floor Price") of Rs. 125 and the maximum price ("Cap Price") of Rs. 150 and includes revisions thereof.
Pricing Date	The date on which our Company in consultation with the BRLMs finalises the Issue Price.
Prospectus	The Prospectus, filed with the RoC containing, <i>inter alia</i> , the Issue Price that is determined at the end of the Book Building Process, the size of this Issue and certain other information.
Public Issue Account	Account opened with the Banker to this Issue to receive monies from the Escrow Account for this Issue on the Designated Date.
QIB Margin Amount	An amount representing at least 10% of the Bid Amount.
QIB Portion	The portion of this Issue being upto 50% of the Net Issue to Public consisting of not more than 18,90,000 Equity Shares of Rs. 10/- each, available for allocation on a proportionate basis to QIBs. 5% of the QIB Portion shall be available for allocation on a proportionate basis to Mutual Funds only.
Qualified Institutional	Public financial institutions as specified in Section 4A of the Companies Act, FIs, scheduled commercial banks, mutual funds registered with SEBI, multilateral and bilateral development financial institutions, venture capital funds registered with SEBI, foreign venture capital investors registered with SEBI, state industrial development corporations, insurance companies registered with the Insurance Regulatory and Development Authority, provident funds with minimum corpus of Rs. 2500 lakh and pension funds with minimum corpus of Rs. 2500 lakh.



TERM	DESCRIPTION
Red Herring Prospectus	Means the document issued in accordance with the SEBI Guidelines, which does not have complete particulars of the price at which the Equity Shares are offered and the size of this Issue. The Red Herring Prospectus, which will be filed with RoC atleast 3 (three) days before the Bid Opening Date and will become a Prospectus after filing with RoC after pricing and allocation.
Registrar / Registrar to the Issue	Registrar to the Issue, in this case being Bigshare Services Private Limited, having its registered office as indicated on the cover page of this Red Herring Prospectus
Retail Individual Bidders	Individual Bidders (including HUFs) who have Bid for an amount less than or equal to Rs. 100,000 in any of the bidding options in this Issue.
Retail Portion	The portion of this Issue being at least 35% of the Net Issue to Public consisting of 13,23,000 Equity Shares of Rs. 10/- each, available for allocation to Retail Individual Bidders.
Revision Form	The form used by the Bidders to modify the quantity of Equity Shares or the Bid price in any of their Bid-cum-Application Forms or any previous Revision Form(s).
RoC	Registrar of Companies.
Stock Exchanges	BSE and NSE
Syndicate	The BRLMs and the Syndicate Members.
Syndicate Agreement	The agreement to be entered into between our Company and the members of the Syndicate, in relation to the collection of Bids in this Issue.
Syndicate Member	Intermediaries registered with SEBI and eligible to act as Underwriters. Syndicate Members are appointed by the BRLMs.
Transaction Registration Slip/ TRS	The slip or document issued by the Syndicate Members to the Bidders as proof of registration of the Bid.
Underwriters	The BRLMs and the Syndicate Members.
Underwriting Agreement	The Agreement among the Underwriters and our Company to be entered into on or after the Pricing Date.

III. COMPANY/ INDUSTRY-RELATED TERMS:

TERM	DESCRIPTION
3G	3 Generation
AC	Alternate Current
AGM	Annual General Meeting
APSEB	Andhra Pradesh State Electricity Board
Articles / Articles of Association / AoA	Articles of Association of the Company
AS	Accounting Standards as issued by the Institute of Chartered Accountants of India
Auditors	The statutory auditors of the Company: M/s Satyanarayana & Co., Chartered Accountants.
B2B	Business 2 Business
Board of Directors / Board	The Board of Directors of XL Telecom Limited or a committee thereof
BSNL	Bharat Sanchar Nigam Limited
BTS	Base Terminal Station
CAGR	Compounded Annual Growth Rate
CCA	Component circuit assembly



TERM	DESCRIPTION
CDMA	Code Division Multiple Access
CKD	Completely Knocked Down
Compliance Officer	Compliance Officer of the Company in this case being Ms. Ch. Bhawani the Company Secretary of the Company.
DC	Direct Current
DG	Direct General
Director(s)	Director(s) of the Company unless otherwise specified
DoT	Department of Telecommunications
EBDITA	Earnings Before Depreciation, Interest, Tax and Amortization
EGM	Extraordinary General Meeting of the Company
EPS	Earnings Per Equity Share
Equity Shareholders	Persons holding Equity shares of the Company unless otherwise specified in the context otherwise.
Equity Shares	Equity shares of face value of Rs.10 each of the Company unless otherwise specified in the context thereof
ESD	Electrostatic discharge
Face Value	Value of paid-up Equity Capital per Equity Share, in this case Rs. 10/- each.
FWP	Fixed Wireless Phone
GNP	Gross National Product
GSM	Global System for Mobile
ICA	Indian Cellular Association
IREDA	Industrial Renewable Energy Development Agencies
KVA	Kilo Voltage Ampere
KWH	Kilo Watt Hour
LED	Light Emitting Device
Memorandum / Memorandum of Association / MoA	The Memorandum of Association of the Company
MMA	Module Mechanical Assembly
MSEB	Maharashtra State Electricity Board
MTNL	Mahanagar Telephone Nigam Limited
PCB	Printed Circuit Board
PCB - IT	Printed Circuit Board –Testing Instructions
Promoters	Mr. Dinesh Kumar & M/s. Smt. Snehlata Lal Family Welfare Trust
PTI	Product Test Instructions
QA	Quality Assurance
QC	Quality Check
Registered Office of Company	Registered Office of the Company situated at 335, Chandralok Complex, Sarojini Devi Road, Secunderabad – 500 003, India.
RUIM	Removable User Identity Modules
SAR	Specific Absorption Rate
SKD	Semi Knocked Down
SMPS	Switch Mode Power System
SMT	Surface Mounting Technology



TERM	DESCRIPTION
SPV	Solar Photovoltaic Systems
The Company / XL / XL Telecom Limited / our Company / we / us / the issuer	Unless the context otherwise indicates or implies refers to XL Telecom Limited, a public limited company incorporated under the provisions of the Companies Act, 1956 with its registered office at 335, Chandralok Complex, Sarojini Devi Road, Secunderabad -500 003, India.
TRAI	Telecom regulatory Authority of India
VoIP	Voice Over Internet Protocol

IV ABBREVIATIONS

ABBREVIATION	FULL FORM
AGM	Annual General Meeting
AY	Assessment Year
B.Sc	Bachelor of Science
BG	Bank Guarantee
BOM	Bill of Materials
BSE	Bombay Stock Exchange Limited
CAGR	Compounded Annual Growth Rate
CDSL	Central Depository Services (India) Limited
CEO	Chief Executive Officer
CMD	Chairman-cum-Managing Director
D/E Ratio	Debt Equity Ratio
DP	Depository Participant
EBDITA	Earnings Before Depreciation, Interest, Tax and Amortization
EGM	Extraordinary General Meeting
EPS	Earnings Per Equity Share i.e. profit after tax divided by outstanding number of Equity Shares at the year end.
ESD	Electrostatic Discharge
ESOP	Employee Stock Option Plan
ESPS	Employee Stock Purchase Scheme
FCA	Fellow Chartered Accountant
FCNR Account	Foreign Currency Non Resident Account
FCS	Fellow Company Secretary
FEMA	Foreign Exchange Management Act, 1999 read with rules and regulations there under and amendments thereto.
FII(s)	Foreign Institutional Investors registered with SEBI under applicable laws.
FIPB	Foreign Investment Promotion Board
FIs	Financial Institutions
FVCI	Foreign Venture Capital Investors registered with SEBI under the SEBI (Foreign Venture Capital Investor) Regulations, 2000
FY / Fiscal	Financial year ending June 30
GIR Number	General Index Registry Number



ABBREVIATION	FULL FORM
GoI	Government of India
HR	Human Resources
HUF	Hindu Undivided Family
ICWA	Institute of Cost and Works Accountant of India
IGI	Inward Goods Inspection
IIM	Indian Institute of Management
IIT	Indian Institute of Technology
INR/ Rs	Indian National Rupee
IPO	Initial Public Offering
IT	Information Technology
LC	Letter of Credit
Ltrs / ltrs	Litres
MBA	Master of Business Administration
MNC	Multi National Company
MoU	Memorandum of Understanding
MP	Management Perception
MW	Mega watt
N. A.	Not Applicable
NAV	Net Asset Value being paid-up Equity Share Capital plus free reserves (excluding reserves created out of revaluation) less deferred expenditure not written off (including miscellaneous expenses not written off) and debit balance of Profit & Loss account, divided by number of issued Equity Shares.
NRE Account	Non Resident External Account
NRO Account	Non Resident Ordinary Account
NSDL	National Securities Depositories Limited
NSE	National Stock Exchange of India Ltd
OCB	Overseas Corporate Bodies
P/E Ratio	Price/Earnings Ratio
PAN	Permanent Account Number
PIJF	Poly Insulated Jelly Filled Cables
PPC	Production Planning and Control
PR	Public Relations
PSU	Public Sector Unit
R & D	Research and Development
RBI	The Reserve Bank of India
RoC	The Registrar of Companies, Andhra Pradesh
RoNW	Return on Net Worth
SBI	State Bank of India
Sec.	Section
Sl. No. / Sr. No. / S.N.	Serial Number
UIN	Unique Identification Number issued in terms of SEBI (Central Database of Market Participants) Regulations, 2003, as amended from time to time.
USD/\$/US\$	United States Dollar



SECTION II: RISK FACTORS AND MANAGEMENT PERCEPTIONS THEREOF

PRESENTATION OF FINANCIAL INFORMATION AND USE OF MARKET DATA

Unless stated otherwise, the financial information used in this Red Herring Prospectus is derived from our Company's restated financial statements as of and for the years ended on June 30, 2002, 2003, 2004, 2005 and 2006 prepared in accordance with Indian GAAP and the Companies Act and restated in accordance with SEBI Guidelines, as stated in the report of our Statutory Auditors, M/s. Satyanarayana & Co., Chartered Accountants, included in this Red Herring Prospectus.

Our fiscal year commences on July 1 and ends on June 30 of a particular year.

In this Red Herring Prospectus, unless the context otherwise requires, all references to one gender also refers to another gender and the word "Lakh/Lac" means "one hundred thousand" and "Crore" means "one hundred lakh". Further, any discrepancies in any table between the total and the sum of the amounts are due to rounding-off. Throughout this Red Herring Prospectus, currency figures have been expressed in "Lakh" except those, which have been reproduced/ extracted from sources as specified at the respective places.

Use of Market Data

Market data used in this Red Herring Prospectus have been obtained from industry publications and internal Company reports. Industry publications generally state that the information contained in those publications has been obtained from sources believed to be reliable but that their accuracy and completeness are not guaranteed and their reliability cannot be assured. Although we believe market data used in this Red Herring Prospectus is reliable, it has not been independently verified. Similarly, internal Company reports, while believed by us to be reliable, have not been verified by any independent source.



FORWARD-LOOKING STATEMENTS

This Red Herring Prospectus contains certain “forward-looking statements”. These forward-looking statements generally can be identified by words or phrases such as “aim”, “anticipate”, “believe”, “expect”, “estimate”, “intend”, “objective”, “plan”, “project”, “shall”, “will”, “will continue”, “will pursue”, “may” or other words or phrases of similar import. Similarly, statements that describe objectives, plans or goals also are forward-looking statements.

All forward-looking statements are subject to risks, uncertainties and assumptions about the Company that could cause actual results to differ materially from those contemplated by the relevant forward-looking statement. Important factors that could cause actual results to differ materially from the Company’s expectations include, among others:

- General economic and business conditions in India and the world;
- The ability to successfully implement the strategy, the growth and expansion plans and technological changes;
- Factors affecting growth of Telecom Industry in the country in general;
- The size, timing and profitability of significant projects;
- The effect of forex fluctuations since the major inputs are imported into the country and not produced within the country as on date;
- Increasing competition in, and the conditions of the global and Indian telecom industry;
- The ability to retain the clients and acquire new clients;
- Changes in the Government Policy regarding the ratio of mixing the Ethanol into Petrol and expanding the number of states where the mixing is made mandatory.
- pricing policies or those of the competitors;
- Cancellations, contract terminations or deferrals of projects or investments by the Telecom Carriers or by the Oil Companies in case of Ethanol;
- Unanticipated variations in the duration, size and scope of the projects/supplies;
- Changes in the value of the Rupee and other currencies;
- Changes in laws and regulations that apply to the industry in which Company is operational; and
- Changes in the political and social conditions in India.

For further discussion of factors that could cause the actual results to differ, please see “Risk Factors” beginning on page xi of this Red Herring Prospectus. By their nature, certain market risk disclosures are only estimates and could be materially different from what actually occurs in the future. As a result, actual future gains or losses could materially differ from those that have been estimated. Neither the Company, the Book Running Lead Managers nor any of their respective affiliates have any obligation to update or otherwise revise any statements reflecting circumstances arising after the date hereof or to reflect the occurrence of underlying events, even if the underlying assumptions do not come to fruition. In accordance with SEBI requirements, the Company and Book Running Lead Managers will ensure that investors in India are informed of material developments until such time as the grant of listing and trading permission by the Stock Exchanges.



RISK FACTORS

RISK ENVISAGED BY MANAGEMENT AND MANagements PERCEPTIONS THEREOF

An investment in equity shares involves a high degree of risk. Investors should carefully consider all of the information in this Red Herring Prospectus, including the risks and uncertainties described below, before making an investment in the Equity Shares. If any of the following risks actually occur, the business, results of operations and financial condition of the Company could suffer, the trading price of the Equity Shares could decline, and you may lose all or part of your investment. Unless specified or quantified in the relevant risk factors mentioned below, the Company is not in a position to ascertain the financial and other implications of any of the other risks mentioned below.

a. RISK FACTORS SPECIFIC AND INTERNAL TO THE COMPANY

TELECOM DIVISION

COMPANY DEPENDS ONLY ON PARTNER'S FOR TECHNOLOGY

1. The Company has been working with several Multi National Companies for over two decades as Technology Partners and import the technology for local manufacturing/assembly before they market the same in India. In that sense the Company is to a large extent, dependent on its Technology partners for different models of CDMA Mobile handsets and Fixed Wireless Phones and procuring components for the manufacturing the same. Similarly for new development of SMPS Systems or any other equipment the Company will be totally depending upon the either existing Technology partners or potentially new Technology partners. Any adverse development in the relationship with the Technology partner may have a negative impact on the future revenues and profitability of the Company. Especially in Mobile segment, where new models needed to market very frequently this may have negative impact if the Technology partner delays in launching the new products.

MANAGEMENT PERCEPTION

XL has record in maintaining relationship with the partners of mutually beneficial nature. XL has entered into reasonably long term relationships with these companies extending up to 2008 with a rider to extend further.

2. GOVERNMENT POLICIES AND CHANGE IN IMPORT DUTY – IMPACT ON BUSINESS

Company's major business is telecom and manufacturing of CDMA mobile phones and FWP phones. This business is basically leveraging the differential duty structure presently being charged for finished phones as compared to establishing manufacturing and importing the CKD/SKD kits so that duty is saved completely and gaining competitiveness too. Withdrawal by the government or change in import duty structure for CKD kits (presently 0%) and complete phone (presently 4%) may have financial impact on profitability of the company.

MANAGEMENT PERCEPTION

Going by the policies of successive governments and the Governments intention to bring in the manufacturing activity into India, especially in Telecom sector, company do not see the reduction in the custom duties beyond the current low rates and consequentially impact on the profitability of the company.

3. RETAIL MARKETING OF CDMA HANDSETS – A NEW FORAY

The Company has entered into retail business model for its CDMA Mobile Handsets, in addition to supplying the Mobile Handsets to Carriers/Service Providers in bulk volumes as being done currently. While Private Carriers wants to continue the bulk purchases for low end models, have asked the Mobile Phone suppliers to go directly to customers and reach through retail business model for high end phones, necessitating the new retail business. The Company's revenues and profitability are dependent on success of this retail business model, hence may vary significantly from quarter to quarter since the retail business is more based on the promotional schemes normally brought out by the Carriers due to 'schemes normally announced on festive seasons'.

MANAGEMENT PERCEPTION

The Company has to adopt itself due to paradigm shift in the business model of CDMA sales in Indian Telecom sector. The Company has tied-up with Telecom Operators like Reliance Infocomm and has already created



'chain of distributors' across the country to reach the 'several thousands of retail stores/shops' of these Telecom Operators.

4. COMPANY HAS NO INTERNAL RESEARCH & DEVELOPMENT WING

The Company is not having any internal Research & Development. The Company is dependent on their Technology partners for supply of technology and new products or models to launch in India. Any adverse development with these partners may impact the business of the Company. The Company is dealing with mobile handset segment, where the tastes and habits of the people change so frequently and is difficult to predict. Especially Mobile Handset business involves too frequent introduction of new and fancy models that meets customer expectations. Company needs to maintain its relationship on a continuous basis and needs to be in touch with technology partners to develop the needs to local requirements.

MANAGEMENT PERCEPTION

The Company over the period has entered into technology partnerships with MNC's like Kyocera, Axesstel, Corning, Siemens etc., and these Technology partners have been providing new products for the Indian market timely at an affordable price. The Company does not see advantage at this point of time to have their own internal R & D and come out with products and create a brand.

ETHANOL DIVISION

5. AVAILABILITY OF RAW MATERIAL FOR ETHANOL (SDS) IS SEASONAL IN NATURE AND THERE IS NO LONG TERM AGREEMENT FOR PROCUREMENT.

The Company has entered into Ethanol Business in the year 2005-06. Ethanol is produced basically from Molasses, which is a by-product of Sugar Production. Currently for manufacturing Ethanol, Company procures molasses and some times get the same converted into SDS through distilleries belonging to others and hence non availability of capacity of distilleries at times or non availability of Molasses through the year, since Sugar is a seasonal business can create a problem.

MANAGEMENT PERCEPTION

Ethanol orders from Oil Public Sector Companies are through tender basis, and normally orders are placed for the yearly requirement. Also these orders will have a delivery period, spread over a year. Hence, though the raw material for Ethanol being Molasses (primary version of SDS) is available during sugar crushing season, the supplies to Oil companies can be effected smoothly.

6. DEMAND IS BASED ON GOVERNMENT POLICIES.

The Company's estimate for demand of Ethanol is based on the Petrol Consumption in India and projected growth in consumption in addition to the projected increase in the percentage of blend of Ethanol with petrol. In India currently Ethanol is being blended at about 5% and that too in 9 States. Any change in the Government policy or the demand for petrol may reduce the demand for Ethanol also.

MANAGEMENT PERCEPTION

Government is expected to expand the mandatory mixing orders to remaining states as well. Similarly we also see Government increasing this percentage of mixing from the current 5% to 10% shortly in line with Western world. Hence, the Company do not see any fall in the demand for Ethanol in India.

SOLAR PHOTO VOLTAIC DIVISION

7. SOLAR ENERGY, IN WHICH THE COMPANY IS PROPOSING ITS EXPANSION PLANS IS A RISKY BUSINESS

The Company is only in the Domestic Market for supply of Solar Photovoltaic Modules for over 10 years. The Company has now plans to enter into export market by substantially increasing the capacity from the existing 1 MW per annum to 24 MW per annum, which is risky since sudden fall in demand globally means underutilization of capacity and also the Solar Photovoltaic cells is in shortage internationally due to sudden surge in demand, which may affect the margins of the company.



MANAGEMENT PERCEPTION

The Company has a Firm Order for 12 MW worth Solar Modules to be supplied before 31.12.2009 from Forta Im-Ex SL. The Company normally negotiates with the customers pricing based on the procurement price of PV Cell and hence the gross margins are reasonably fixed and do not fluctuate based on the change of raw material prices.

8. RISK OF RUPEE DEPRECIATION

Company proposes to invest Rs. 800 Lakh out of the proceeds to be raised through this public issue for the Solar modules manufacturing facility. The Company is exposed to foreign currency risk since some of the machinery is imported. XL has embarked on the expansion plans in Solar Systems for export market. Any depreciation of Indian Rupee vis-à-vis USD or Euro will have an impact on the revenues and profitability of the Company.

MANAGEMENT PERCEPTION

This project has made necessary contingency provisions to take care of any adverse exchange fluctuations. As far as exports are concerned, the company normally hedges itself to deal with the exchange fluctuation, while negotiating the export pricing of company's products. However, like any other business, the company business is subject to the risk of abnormal variation in the exchange rates.

9. PENDING ORDER PLACEMENT FOR FURNITURE AND FIXTURES

The Company is yet to place certain orders for some of the Furniture and Fixtures required for SPV Module manufacturing facility plant and SMT Line in CDMA Division since these need to be custom specific. The value of these pending orders is worth Rs. 20 Lakh.

MANAGEMENT PERCEPTION:

The Company has placed orders for all the major machinery and equipment except in the case of furniture and fixtures, which is less than 1% of the total project cost. Orders for this can be placed on arrival of machinery so that the specifications are clear.

GENERAL

10. ONE OF THE PROMOTERS OF THE COMPANY IS A PRIVATE TRUST.

One of the two Promoters of the Company is a Private Trust with a limited period of existence up to the Year 2013. The Trust has beneficiaries as minors and it is difficult to predict the continuation of holding of these shares held by Trust beyond 2013, which means that the promoter shareholding may go down by 2013, in case the beneficiaries decide to dissolve the Trust.

MANAGEMENT PERCEPTION

The trust has become the Promoter by virtue of inheritance and Period of the Trust was originally up to 2006 and the same has already been extended up to 2013. From time to time the Trustees along with the Beneficiaries can decide to extend the period of Trust as was done earlier.

11. VARIATION IN THE REVENUES & PROFITS

The Company's revenue is mainly from large Telecom Operators. Similarly the Company depends upon Oil companies for their Ethanol supplies. These large companies normally go through their own internal procurement policies, which is public tender model for the yearly requirements in the case of Public Sector companies and 'need' based procurement model in the case of private companies. The Company's revenues and profitability are dependent on several such factors and may vary significantly from quarter to quarter. The company depends on certain public sector companies, who go through elaborative open tender process for procurement, which in turn can delay their procurement. Therefore, the historical financial results may not be an accurate indicator of future performance.



MANAGEMENT PERCEPTION

The orders from Telecom Operators and Oil Companies are generally not spread uniformly through out the year and hence the revenues and profitability could differ significantly from quarter to quarter.

12. THE PROJECT HAS NOT BEEN APPRAISED BY ANY BANK OR FINANCIAL INSTITUTION.

All the figures under the utilization of funds raised are based on company's own estimates. There has been no independent appraisal of the project by any financial institution. The project may be subject to various unforeseen variableness such as possible cost overrun or delays in implementation.

MANAGEMENT PERCEPTION

The Company has been working for over 20 years and has the ability to identify and establish new projects with its experience in establishing several projects especially in last five years.

13. SUCCESS IN ATTRACTING AND RETAINING PROFESSIONALS

Business depends on quality professionals and their longevity with the company. The Company's success depends in large part upon its highly skilled professionals and its ability to attract and retain these personnel.

MANAGEMENTS PERCEPTION:

The Company is successful in retaining its workforce and also investing in their skills improvement. The Company is ensuring certain percentage of Public Issue as a reservation for Employees to the Employees to give the benefit of growth and creating the feeling of ownership to the Employees.

14. DEPENDENCY ON SENIOR MANAGEMENT

The top management is committed to the business of the Company and have pioneered foray into the current lines of businesses. Further many of senior management team has been working with the company for several years The Company's success depends upon its senior management and key personnel and its ability to attract and retain them.

MANAGEMENT PERCEPTION

The company's working environment and new ESOP policy post IPO and Reservation of Shares, as part of Public Issue to Employees should ensure in improving the retention model.

15. COMPANY IS IN COMPETITIVE BUSINESS ENVIRONMENT

The Company operates in a highly competitive business environment and it is likely to continue to be in the future as well. The business of Mobile Phones or Fixed Wireless Phones is generally in a very competitive in both pricing and frequency with which the company need to introduce newer models. Similarly Ethanol being a Tendered base business, Company needs to be extremely cost competitive to win the tenders and gain business on regular basis.

MANAGEMENT PERCEPTION

At present, there are fewer, but more serious, players in the market. The Company maintains its competitiveness through innovative service offerings, responsive customer care and attractive pricing in addition to attractive product offerings.

16. COMPANY DEPENDS ON PSUs FOR BUSINESS

The revenues of Company are highly dependent on a limited number of PSU buyers. Any slow down in the government spending may adversely affect the revenues and profits of the Company. Especially in Ethanol division the Company only depends upon the PSU buyers and any change in the mixing of Ethanol into Petrol from the existing 5% can effect the revenues of the company on either side.



17. PART OF BUSINESS IS THROUGH TENDER BASED MODEL – FAILING TO WIN THE TENDERS COULD AFFECT THE BUSINESS.

Telecom and Ethanol business of the Company is derived through the public tendering of Government Companies. Any shortfall in the estimates may adversely affect the revenue earning potential of the Company. Similarly not winning tenders due to competitiveness or position in the Tender may vary the Company's revenues as well.

MANAGEMENT PERCEPTION

The Company has been in the business for about 20 years and has developed skills in participating in tenders of Public Sector Companies despite the severe competition from large players.

18. RISK OF COST AND TIME OVERRUN

Company's expansion plans in the Solar Photo Voltaic Module Plant capacity from 1 MW to 24 MW and the backward integration project of creating Surface Mounting Technology based Assembly Line for producing CDMA Mother Board for both CDMA Mobiles and Fixed Wireless Phones are subject to the risk of cost and time overruns. Expansion plans having not been appraised by any financial institution are subject to number of contingencies, changes in laws and regulations, government actions, accidents, natural calamities, terrorist activity and other factors, many of which may be beyond company's control.

MANAGEMENT PERCEPTION

Company intends to apply the net proceeds of the Issue to broad base the operations and reduce financial costs by using funds for prepayment of loans and for working capital of retail business. Although Company has taken steps to complete the expansion plan within parameters estimated, there cannot be any assurance that the actual costs incurred, time taken for implementation of these plans will not vary from estimated parameters.

19. ALLOTMENT OF EQUITY SHARES TO PERSONS OTHER THAN PROMOTER / PROMOTER GROUP AT A PRICE LOWER THAN THE ISSUE PRICE TO BE DISCOVERED THROUGH BOOK BUILDING IN THIS ISSUE.

Company has made the following allotments of Equity Shares to persons other than Promoter / Promoter Group the price of such issues may be lower than the Issue Price:

Date	Number of Shares	Face Value	Issue Price	Details
05-05-2006	10,00,000	10/-	100/-	Issue of Equity Shares to 2i Capital PCC, a SEBI Registered Venture Capitalist Firm.

20. ANY FUTURE ISSUANCE OF EQUITY SHARES BY COMPANY MAY DILUTE EXISTING INVESTORS HOLDING PERCENTAGE IN THE COMPANY.

To fund future growth plans, Company may further raise capital by way of issuance of Equity Shares or convertibles in domestic or overseas market. Such further issuance of Equity Shares or convertibles could dilute your shareholding in the Company. Further, perception of such further Issues may also affect the trading price of Equity Shares.

Also, sale by the Promoters or major shareholders of their shareholding (subject to lock-in compliances) may affect the trading price of the Equity Shares of Company.

21. PROMOTERS MAY BE DEEMED TO BE INTERESTED TO THE EXTENT OF EQUITY SHARES HELD BY THEM, THEIR FRIENDS OR RELATIVES OR THE GROUP COMPANIES, AND BENEFITS ARRIVING FROM THEIR DIRECTORSHIP IN COMPANY. THE PROMOTERS ARE INTERESTED IN THE TRANSACTION ENTERED INTO BETWEEN COMPANY WHERE PROMOTERS ARE INTERESTED EITHER AS A PROMOTER, DIRECTOR, PARTNER, PROPRIETOR OR OTHERWISE.



22. CASE FILED BY THE COMPANY

The Company has filed a writ petition with the Hon'ble High Court of Judicature at Mumbai in the year 2004 against the State of Maharashtra questioning the State powers to regulate and control the Indian Alcohol or Ethanol after denaturalization or rectified spirit. Also whether the provisions of Bombay Denatured Spirit Rules, 1959 in respect of transport, export, import or dehydration of denatured spirit are ultra vires of the Constitution. The Outcome of the case can have impact on the revenues and profitability of the company positively or adversely.

23. INCOME TAX PROCEEDINGS AGAINST THE COMPANY AND PROMOTERS

Income Tax authorities under the provisions of Section 132 of the Income Tax Act, 1961 carried out a search during the month of Sep 2005, at the premises of Company, the Promoters. During the course of search the Company and Promoters have admitted certain undisclosed income; the final assessment would impact on the profits of the company to the extent of not provided for in the books.

MANAGEMENT PERCEPTION

The Company has filed the Block Assessment return in respective of the above matter. The company has already provided for Rs.365 Lakh of Income Tax payable as on 30th June 2005, which covers the Income Tax payable for disclosers even. There is no future impact of Tax Liability in respect of the search proceedings.

24. PENDING INCOME TAX PROCEEDINGS AGAINST THE GROUP COMPANY, SOFTPROJEX (I) LIMITED MAY HAVE ADVERSE EFFECT ON THE COMPANY

The Group Company has been part of the overall search of Income Tax Authorities under the provisions of section 132. However, since the Company being 100% EOU, there is no liability arrived by the IT Authorities.

25. CASES AGAINST THE DIRECTOR OF THE COMPANY

The following are the list of cases filed against one of the Director Shri Ashok Kumar Goyal who was formerly working as Director and Company Secretary in Xerox Modicorp Limited and Indian Management Advisors & Leasing (P) Limited:

Case No.	Cases Filed by	Court	Charges/Allegations	Present Status
709/2003	ROC, Kanpur	Spl Chief Judicial Magistrate-Meerut	Non compliance of the provisions of Sec-211 read with Schedule VI of the Companies Act	The matter is Compounded by Regional Director, Northern Region under section 621-A of the Companies Act, 1956 (Matter yet to be withdrawn)
710 /2003	ROC, Kanpur	Spl Chief Judicial Magistrate-Meerut	Non compliance of the provisions of Sec-193(1) of the Companies Act	The matter is Compounded by Regional Director, Northern Region under section 621-A of the Companies Act, 1956 (Matter yet to be withdrawn)
711/2003	ROC, Kanpur	Spl Chief Judicial Magistrate-Meerut	Non compliance of the provisions of Sec-209 (1) of the Companies Act, 1956.	The matter is Compounded by Regional Director, Northern Region under section 621-A of the Companies Act, 1956 (Matter yet to be withdrawn)
499/2004	DCIT, Circle 9(1), New Delhi	Additional Chief Metropolitan Magistrate, Tis Hazari Courts, New Delhi	Claim of Depreciation in lease transaction disputed by department	Proceedings are still pending.



Case No.	Cases Filed by	Court	Charges/Allegations	Present Status
41/1994	ITO, Spl Range 24, New Delhi	Additional Chief Metropolitan Magistrate, Tis Hazari Courts, New Delhi	Claim of Depreciation in lease transaction disputed by the Department of Income Tax	Proceedings have been stayed by the Hon'ble High Court of Delhi

The aggregate amount of financial impact of these cases / litigations / disputes have been disclosed to the extent possible in the respective places.

26. CONTINGENT LIABILITIES

Risk associated with Contingent Liabilities as on June 30, 2006 is as follows:

Particulars	Amt. (Rs. in Lakhs)
Letter of Credit	3956.95
Guarantees & Counter Guarantees	2215.83
Capital Commitment	2840.00
TOTAL	9012.79

27. NEW CUSTOMER ACQUISITION

Currently, company majorly supplies to BSNL, TATA and Reliance Infocomm. The Company's growth depends on these customers and acquiring new customers for its products apart from increasing business from existing customers. Any discontinuance of supply to these existing customers and inability to acquire new customers will affect the revenues and profitability of the Company.

MANAGEMENT PERCEPTION

Company has several products in its portfolio and have always been doing well in offering new products and services to customers for the new products. The Company has been successful through its management team to expand customer base from time to time both with in the country and also outside country for export opportunities.

28. DELAY IN IMPLEMENTATION SCHEDULE OF THE PROPOSED PROJECT:

Company proposed project is sourced only through raising of funds through issue of equity to public. Because of delay in the process of sourcing this funds, there is consequential delay in implementation schedule of the proposed project.

29. RISK OF TECHNOLOGY OBSOLESCENCE

CDMA Technology has been working for a little over ten years in USA and since 2003 in India and global majors have been putting significant effort in the continuous improvement and updation of the CDMA technology. Changes in technology may render Company's current plant & equipments obsolete or require it to make substantial capital investments for latest technologies.

MANAGEMENT PERCEPTION

Company's technology partners being MNCs have been providing the company with the latest technology, updated products and the company being not in the product development as such is sufficiently insured by itself in the process, excepting that the Company may need to re-engineer its assembly lines depending upon the product design and technology, which is not expensive to dictate the profitability of the company.

30. CHANGE IN REGULATORY POLICIES

Telecom growth prospects are highly dependent on Government Policies. Any change in the regulatory authority policies favouring the GSM Operators may have an adverse impact on the CDMA handsets business and consequently will have a negative impact on the sales & profitability of the Company.



MANAGEMENT PERCEPTION

Telecom Regulatory Authority of India has not been favouring one technology over the other and has been considering the mobile operator as such. The transparency with which the Indian Government and the regulator TRAI has been working, the Company does look forward to advanced information and time for the operators to effect any changes, which will ensure giving sufficient time frame to change the business policies and direction to ensure continuity of revenues and profitability.

b. RISKS EXTERNAL TO THE COMPANY

1. GLOBALLY COMPETITIVE ENVIRONMENT

The Company operates in a globally competitive business environment. Growing competition may force it to reduce the price of its products which may reduce its revenues and margins and/ or decrease its market share, either of which could have a materially adverse effect on its business, financial condition and results of operations.

MANAGEMENT PERCEPTION

The Company endeavours to increase the scope, volume and value of business in a competitive and risk-prone environment. It may rationalize its product and service offerings from time to time to leverage core competency and maintain competitiveness in addition to work with partners to make the product cost effective to be able to compete in the market.

2. DISRUPTION OF UTILITY SERVICES

Any disruption in the supply of power, telecom infrastructure and telecom lines could disrupt the company's business process or subject it to additional costs.

MANAGEMENT PERCEPTION

Company has made adequate arrangements of back up infrastructure like DG Sets etc., and feel that the company is adequately insured from such happenings except for unusual situations.

3. STABILITY OF POLICIES & POLITICAL SITUATION

Infrastructure growth prospects are highly dependent on Government policies. A significant change in India's economic liberalization and deregulation policies could affect the business and economic conditions in India, which in turn could have an impact on the Indian companies with a concurrent effect on the market for the Company's products and services.

MANAGEMENT PERCEPTION

The economic liberalization process is continuing in India and there is a reasonable consistency in the policies despite change in the governments and there is a reason to believe that it will continue through the foreseeable future.

4. FOREIGN EXCHANGE FLUCTUATIONS

Parts of the Company's revenues and expenses are denominated in US Dollars and other international currencies. Thus the Company faces the risk of fluctuating exchange rates.

MANAGEMENT PERCEPTION

The Company normally ensures taking adequate business insurance of the exchange rate fluctuations by taking forward contracts in consultation with Industry experts. Any depreciation or appreciation of rupee vis-à-vis foreign currencies that could happen beyond the normal fluctuations in the daily trading is difficult to predict and provide for and your company is at risk as much as the entire Indian economy to that extent.

5. There can be no assurance that an active trading market for the equity shares will develop or be sustained after this Issue, or that prices at which the Company's equity shares are initially offered will correspond to the prices at which the Company equity shares will trade in the market subsequent to this Issue. The price of the



Company's equity shares in Indian stock exchanges may fluctuate after this Issue as a result of several factors, including:

- a. Volatility in the Indian and Global securities market;
- b. The results of operations and performance;
- c. Perceptions about the Company's future performance or the performance of Indian telecom companies;
- d. Performance of the Company's competitors in the Indian telecom industry and market perception of investments in the Indian telecom sector;
- e. Adverse media reports on the Company or on the Indian Telecom industry;
- f. Change in the estimates of the Company's performance or recommendations by financial analysts;
- g. Significant development in India's economic liberalization and deregulation policies; and
- h. Changes in the applicable tax incentives;
- i. Significant development in India's fiscal and environmental regulations.
- j. The exchange rate of USD or Euro or any other relevant currency; and
- k. General political and security environment in the country and across the globe.

MANAGEMENT PERCEPTION:

There has been no public market for the Company's equity shares till now and the prices of the Company's equity shares may fluctuate after this Issue. The Company's share price could be volatile and may also decline.

6. EFFECT OF NATURAL CALAMITIES, TERRORISM AND VIOLENCE – FORCE MAJEURE

Terrorist attack and other acts of violence or war involving India, the United States, and other countries could adversely affect the financial markets and adversely affect business.

Certain events that are beyond Company's control including the recent tsunami or seismatically generated sea wave capable of considerable destruction, which affected several parts of South and South East Asia, including India on December 26, 2005 and terrorist attacks, such as the ones that occurred in New York and Washington DC on September 11, 2001 and in New Delhi on December 13, 2001 and other acts of violence or war (including civil unrest, military activity and hostilities among neighbouring countries, such as between India and Pakistan) which may involve India, the United State or other countries, may adversely affect worldwide financial markets and could lead to global economic recession. These acts may also result in a loss of business confidence and have other consequences that could adversely affect our business, results of operations and financial condition. Furthermore any of these events could lower confidence in India as an outsourcing base in the Global economy. Any such event could adversely affect Company's financial performance or the market price of the Equity Shares.

7. CHANGES IN THE DOMESTIC TAX LAWS

Any changes in the tax laws in India particularly Income Tax might lead to increased tax liability of the Company thereby putting pressures on profitability.

MANAGEMENT PERCEPTION

Change in tax laws, particularly income tax, can have an impact on the post-tax profits of the Company.

Notes:

1. Pre-Issue Net worth of the Company as per the financial accounts of the company for the period ending on June 30, 2006 is Rs. 7873.75 lakhs. The Book Value per share as on the same date is Rs. 74.68 and the size of this issue is Rs. [●].
2. The Investors are advised to refer to the section on "**Basis for Issue Price**" beginning on page 31 before making an investment in this issue.



3. Size of the present Issue is of 39,56,808 equity shares of Rs.10/- each for cash at premium of Rs [●] /- per share aggregating to Rs. [●] lakhs. This Issue comprises of reservation of 1,76,808 Equity Shares aggregating Rs. [●] lakh for Eligible Employees on a Competitive basis and the Net Issue to Public of 37,80,000 Equity Shares aggregating Rs. [●] lakhs. The net Issue would constitute 26.07% of the Post Issue Paid-up Capital of our Company.
4. The Issue is being made through a 100% Book Building Process wherein up to 50% of the Net Issue will be allocated on a Proportionate basis to Qualified Institutional Buyers (“QIBs”) (including 5% thereof to be allocated to Mutual Funds). Further, at least 15% of the Net Issue will be available for allocation on a proportionate basis to Non-Institutional Bidders and at least 35% of the Net Issue will be available for allocation on a proportionate basis to Retail Individual Bidders, subject to valid bids being received at or above the Issue Price.
5. Investors may please note that in the event of over-subscription, allotment shall be made on a proportionate basis in consultation with the Bombay Stock Exchange Limited - the Designated Stock Exchange.
6. The average cost of acquisition of Equity Shares of the promoters is as under:

Name of the Promoter	Average Cost of Acquisition per Equity Share (in Rs.)
Snehlata Lal Family Welfare Trust	Rs. 1.18/- *
Mr. Dinesh Kumar	Rs. 3.70/-

*Substantial Holding of the Trust has been through transmission of shares with out any cost to trust, by the erstwhile promoters.

7. For any complaint/ clarification/ information pertaining to the Issue, the investors may contact the Book Running Lead Managers or the Compliance Officer who will be obliged to attend to the same.
8. The Company has made Bonus Issue thrice so far, i.e., 27, 544 Equity Shares were allotted on 16th September 1989 in the ratio of 3 shares for every 5 Shares held and 31,181 Equity Shares allotted on 19th January, 1991 in the ratio of 2 Shares for every 5 Shares held. These shares were of the face value of Rs. 100/- each. However the face value of Shares of the Company has been subdivided subsequently in the Extra-ordinary General Meeting held on 9th March, 1992. The last bonus issue being made of 47,71,596 Equity Shares were allotted on 3rd March 2006 issued in the ratio of 1 Share for every 1 share held. Except bonus issues mentioned above there has been no capitalisation of the profits of the Company.
9. The Book Running Lead Managers and the Company shall make all information available to the public and investors at large and no selective or additional information would be available for a section of the investors in any manner whatsoever.
10. Related Party Transactions Disclosures: Other than as disclosed either in related party transaction or otherwise, the promoters / directors / key management personnel of our Company have no interest other than reimbursement of expenses incurred or normal remuneration or benefits arising out of the shareholding in our Company or out of any business relation with any of the ventures in which they are interested. For interests of promoters and directors, please refer the section titled “Our Management” and “Our Promoters” beginning on pages 70 and 81 respectively of this Red Herring Prospectus.



SECTION III: INTRODUCTION

SUMMARY OF THE INDUSTRY AND BUSINESS

Indian Telecom Industry

India has large pool of qualified and experienced professionals in various disciplines, particularly in information technology, telecommunication technology. English is widely spoken among professionals and in the business community as well as in many Government Offices across India. Successive Governments, since 1991, have laid emphasis on economic reforms resulting in lesser controls and liberalization of economic policies.

In pre-reform period till 1994, Indian Telecommunication Industry was largely driven by Public sector model – monopoly regime, resulting in higher costs to customers and low Tele-density. This can be clearly seen from the marginal growth in the Tele-density of 0.02 in 1948, the first year of Indian Independence to 1.94 in 1998, a meager growth of 1.92 in 50 years.

Government of India's Telecom liberalization program initially started in the year 1994 with National Telecom Policy and then followed by setting up of Regulatory Authority (Telecom Regulatory Authority of India or TRAI) in 1997. The first Tariff order was passed in 1998, thus effecting realistically reform process in Indian Telecom Industry. National Telecom Policy 1999 pushed further this reform process, resulting phenomenal growth in Tele-density, called Phase II and the growth was largely driven by competitive mobile segment.

Post Reforms, the Tele-density jumped from 1.94 in 1998 to 5.11 in 2003 and further due to certain key decisions by GOI and TRAI, mobile segment has created growth to Tele-density from 5.11 in 2003 to 9.11 in 2005 and further to 15.44 in Sep 2006. As one can see, the country witnessed only 1.92 Tele-density in the first 50 years where as in each of 2003-04 and 2004-05 the Tele-density has added about 2. Further due to creation of competitive environment and opening of the sector the prices have fallen significantly benefiting the large Indian consumers.

The Cellular and fixed line penetration levels in India are still lower than those in most developed countries in the world, offering potential for growth in the telecommunication Industry. In recent years, the Indian Telecommunication Industry has experienced high growth, though second only to China.

The total number of Cellular subscribers has reached about 129.51 million significantly surpassing the landline subscribers of 40.75 million in Sep 2006, clearly indicating the growth drivers. The total Telecom Subscribers stands at 170.26 million with 15.44 Tele-density as at the end of Sep 2006.

(Source TRAI Press Releases published in their website www.trai.gov.in)

Indian Telecom Regulatory Authority conducted a survey and came out with targets/ projections for the next 3 years based on the demand in India considering both in Urban and Rural segments in addition to thrust being given by the Telecom Minister and his growth plans for the country. According to TRAI:

1. The Tele-density should reach to 22.50 from the current 15.44 (as of Sep '06) – EACH YEAR MUST GROW GREATER THAN 4.5.
2. This means in absolute terms – 250 million connections by 2008 – a whopping 100% growth over current 123.44 million connections in three year period.
3. Fixed Line connections are expected to increase from the existing 40.75 million as of 30.9.2006 to 70 Million by 2008 – MARGINAL GROWTH IN LINE WITH OTHER COUNTRIES
4. Mobile segment (GSM & CDMA combined) should witness growth from the existing 129.51 millions as of 30.9.2006 to 180 million by 2008 – this means additional subscriber base should go up from the current 1.5 to 2 million per month to > 4 million.



BUSINESS OVERVIEW

XL Telecom's business is divided into three Strategic Business Units.

- i. Telecom – Mobile Handsets, SMPS etc.,
- ii. Solar Photovoltaic Systems
- iii. Ethanol

STRATEGIC BUSINESS UNITS

(I) TELECOM DIVISION

a. CDMA Mobile Handset Manufacturing:

XL has partnered with International Brand KYOCERA for establishing an assembly unit for CDMA Mobile Handsets. XL has currently installed capacity of over 3 Million Handsets per annum. XL is the only independent assembler / manufacturer of CDMA handsets, while other Competitors like LG and Samsung have established their own units in India.

Industry Leaders like BSNL and MTNL have made it compulsory for the vendors to establish the manufacturing facility to be eligible to participate in their tenders. Further, with the establishment of the manufacturing facility, XL could compete in the extremely tough price sensitive market like India, especially leveraging the duty differentials.

The Company has supplied to all CDMA Operators like BSNL, MTNL, TATA and Reliance over 1 Million Mobile Phones and about 15 Models.

The Company is in a position to keep pace with the growing market/technology requirements and is equipped to participate in VoIP and 3G Technology at an appropriate time.

Market:

At the end of June 2006, there were estimated 112.15 Million Cellular subscriptions, out of which CDMA connections accounted for about 26.87 Million, which is about 24%. New Additions in the CDMA Mobile Segment alone is of the order of 5.92 million in the April to June 2006 quarter, accounting for about 26.90% of total additions. (Details are discussed at length in Industry Scenario).

Mobile Phone Segment in India is rapidly growing and is second only to China. The Industry has grown almost 10 times from March 2003 to Sep, 2006, from 13 million in March 2003 to about 129.51 million in Sep 2006. The Industry is expected to continue to see these (70 to 80% per annum) growth rates in the coming years. During the current fiscal year the Industry has grown about 43.67% in the first 6 months ending Sep 2006. As per TRAI and other various research organizations, the Mobile segment is expected to touch to 180 million by 2008, effectively another 39% growth in the next 1.5 years time frame.

Jan Campbell, Managing Director of Ericsson India, expects India's mobile base to reach 100 million by 2006 and surpass 200 million 2008-09. "There is serious demand. The bottom of the pyramid in India is very wide and the addressable market size is big when prices are low".

Indian operators are aggressively expanding their networks into smaller towns and rural areas, pushing up handset demand significantly. "The key will be the network expansion into provincial towns, where there was limited or no presence in the past. Growth will then come mainly from the low-end handset market and the youth." Says Kobita Desai, principal analyst Gartner India. CDMA handset Market in the country will touch \$3.5 Billion in 2007 and \$4.17 billion by 2010 as compared to an estimated \$1.6 Billion at the end of 2004, as per Indian Cellular Association.

Source: TRAI Press releases and Tele.net magazine, AUSPI website

With the announcement of TATA and BSNL to expand the services for another few thousands of towns, especially in the rural segment Company sees opportunity and growth for the company in the areas of CDMA handsets and Fixed Wireless Phones. BSNL has announced to add close to 75 Million Lines in the coming year alone to reach out the emerging rural market segment.

Handset demand: 2004-2008 (volumes)

(Millions)

Year	GSM	% annual	CDMA	% annual	Total
2003	11.80	6	17.8		
2004	18.52	56.9%	5	(-)17%	23.52
2007	56.46	45%	15.24	45%	71.70
2008	81.87	45%	22.10	45%	103.97

Source: Research Report from Tele.net



XL Estimates for their CDMA Sales:

Considering the opportunity in the Mobile Segment and more particularly, the CDMA mobile segment, XL is positioning itself to have significant Market share both in the low end high growth mobile handset segment sold through volume sales to Telecom carriers and higher-end mobile phones through Open market operations for higher price and margin realization for the next 3 to 5 years. The decision to create the distribution network across the country in the 3rd Quarter of 2005 should help the company to reach the potential customer base without any problems. Accordingly, XL has launched its retail sale model through their 'OPEN MARKET OPERATIONS' in December 2005. XL expects to complete creation distribution network to reach 10,000 sales multi-brand sales outlets shortly.

b. SMPS POWER SYSTEMS:

XL has established a facility to manufacture SMPS Power Systems in Technology transfer from SMPS De Austria in the year 2000 with a capital outlay of about Rs.950 Lakhs, largely funded by IDBI and the balance from internal accruals. XL has full range of power systems needed by several Telecom Operators like BSNL, MTNL, Reliance, Bharti etc., SMPS Power Systems manufactured by XL has enabled the Company to enter into international network integrators like Nortel, Erricson etc., XL supplies complete range to help the carriers to meet their demands.

Market:

As per Company's estimates, SMPS Power Systems market is estimated at about Rs.12500 lakhs per annum. XL has been enjoying the market share between 10 to 20% for the past 5 years. With the ever increasing Telecom penetration and the projected 250 Million connections target by 2008, there is growth opportunity for the product both in Telecom exchanges of conventional wired line requirement and BTS stations in the mobile segment. XL is confident of retaining its current market share in the coming years.

c. OUTSIDE PLANT ACCESSORIES:

(Jointing Kits, Optic Fiber Accessories, Fusion Splicers etc.)

XL has been supplier of these outside plant accessories for over 2 decades with a market share of about 40% in Jointing Kit business. However, with the evolution of mobile segment and growth in the Tele-density in the last 7 years only due to mobile penetration, the demand for the company's Jointing kits has come down drastically. However, with the new thrust for the land line growth by the Telecom Minister from existing 46 Million lines to 70 million lines by 2008, the Company is expected to have reasonable level of revenues, though miniscule compared to over all revenues.

(ii) SOLAR PHOTO VOLTAIC SYSTEMS:

XL has established Solar Photo Voltaic Module Manufacturing facility in the year 1995. XL has initially has entered into this segment to largely cater to BSNL's Village Public Telephone requirements valued about Rs.25000 Lakhs.

XL has received orders in the first year of establishment, valued over Rs.3000 lakhs and executing with in the time frame stipulated by BSNL and meeting all the quality standards and going through approval procedures etc.,

However, due to various political reasons, BSNL has decided in the subsequent years to drop the procurement of SPV Systems, which in turn helped Company to focus in other Non-conventional Energy Segments. XL product range includes, Solar Photovoltaic Power Plants – stand alone and Grid Based, SPV Home and Street Lighting Systems, Solar Lanterns etc.,

XL is a supplier of these SPV Systems to various Non-Conventional Energy agencies for the past decade and have also export its Modules to various countries.

Currently looking at the demand in Germany and other parts of Europe for the SPV Systems, XL has entered into 'exclusive distribution agreement' with Forta Im Ex SL, a Spanish Company with a minimum commitment of 3 MW per annum. The agreement is valid for a period of 3 years and the total minimum uplift committed by the European customer is of the order of 12 MW which at current prices works Rs.22000 Lakhs.

This exclusive agreement stipulates that XL telecom limited will supply Solar Photo Voltaic Modules in Spain through Forta Im Ex SL only.

(iii) ETHANOL:

Ethanol is used as an automotive fuel by itself and can be mixed with gasoline to form what has been called 'gasohol'. FUEL THANOL – the most common blends contains 10% of Ethanol. Because of the ethanol molecule contains oxygen, it allows the engine to more completely combust the fuel, resulting in fewer emissions. Since ethanol is produced from plants that harness the power of sun, ethanol is also considered a renewable fuel.

XL has established manufacturing facility at Nanded, Maharashtra after obtaining the necessary license. XL is one of the largest licensed and production capacity currently in India with 1,50,000 litres capacity per day. XL facilities have been inspected and cleared technically by Oil companies both in terms of capacity evaluation and the quality of the product being produced. XL has started the supplies in the year 2006 and has achieved revenues of Rs.5938.14 Lakh in the year 2005-06.

**Market:**

Demand for fuel Ethanol depends on the projected growth in petrol demand in the country. As per IDBI study (July 2002), the demand for petroleum products is estimated to grow at a CAGR of 4.5% and reach 122 million tones by FY 2007. Accordingly the demand for petrol is estimated at 9.85 million tonnes or 13.3 billion litres and demand for anhydrous ethanol works out to around 668 million litres by FY 2007, based on the current policy decision of 5% Mix allowed by GOI.

Demand for Fuel Ethanol	2005	2006	2007
Demand for Petrol			
Million Tonnes	8.60	9.20	9.85
Billion Litres	11.66	12.48	13.35
Demand for Ethanol			
Million Litres @5%	583.13	623.88	667.62
Million Litres @10% Blend	1166.26	1247.76	1335.24
Market Value @Rs.20 Per Ltr	Rs.2300 Crs	Rs.2500 Crs	Rs.2700 Crs

Source: IDBI Study Paper (July 2002) amended with the current Market Price



B. Issue Details in Brief

Equity Shares issued through:	
Fresh Issue by the Company	39,56,808 Equity Shares, constituting 27.29% of the Post-Issue Paid up capital of the company, aggregating to Rs. [●] Lakhs
Of Which:	
Employee Reservation Portion ⁽¹⁾⁽²⁾	1,76,808 Equity Shares aggregating to Rs. [●] Lakhs (allocation on a proportionate basis)
Therefore:	
Net Issue to the Public ⁽²⁾	37,80,000 Equity Shares aggregating to Rs. [●] Lakhs
(i) QIB Portion ⁽³⁾ aggregating to Rs. [●] Lakhs	Upto 18,90,000 Equity Shares, i.e. upto 50% of the Net Issue to Public
Of which:	
Reservation for Mutual Funds	94,500 Equity Shares, i.e. upto 5% of the Net Issue to QIB aggregating to Rs. [●] Lakhs (allocation on a proportionate basis)
Balance for all QIBs including Mutual Funds	17,95,500 Equity Shares (allocation on a proportionate basis)
(ii) Non Institutional Portion	At least 5,67,000 Equity Shares, i.e. minimum 15% of the Net Issue to the Public aggregating to Rs. [●] Lakhs(allocation on a proportionate basis)
(iii) Retail Portion	At least 13,23,000 Equity Shares, i.e. minimum 35% of the Net Issue to the Public aggregating to Rs. [●] Lakhs(allocation on a proportionate basis)
Equity Shares outstanding prior to the Issue	105,43,192 Equity Shares of face value of Rs. 10/- each
Equity Shares outstanding after the Issue	1,45,00,000 Equity Shares of face value of Rs. 10/- each
Objects of the Issue	Please see the section entitled "Objects of the Issue" on page 22 of this RHP.

Notes:

- (1) Eligible Employees of the Company shall be entitled to apply in the reserved category for Employees portion. However, the Promoter Directors and Promoter Group (relatives of Promoters) shall not be eligible to apply in the Employees Reservation Portion
- (2) The unsubscribed portion, if any, in the employee reservation portion will be added back to Net Issue to Public and will be considered for allotment only on a proportionate basis. Under-subscription, if any, in the QIBs portion, Non- institutional portion or Retail Individual Investors shall be allowed to be met with spillover from the other categories, at the sole discretion of the Company and BRLMs.
- (3) As per the amendments to the SEBI Guidelines, allocation to QIBs is proportionate as per the terms of this RHP. 5% of the QIB Portion shall be available for allocation to Mutual Funds. Mutual Funds participating in the 5% reservation in the QIB Portion will also be eligible for allocation in the remaining QIB Portion.



SUMMARY OF FINANCIAL DATA

The following table sets forth the selected historical consolidated financial information of XL Telecom Limited derived from its restated consolidated financial statements for the fiscal years ended June 30, 2002, 2003, 2004, 2005 and 2006, prepared in accordance with paragraph B(1) of the Part II of the Schedule II of the Companies Act, and SEBI guidelines, and restated as described in the auditor's report of M/s. Satyanarayana & Co., included in the section titled "Financial Information" on page no 85 of this RHP and should be read in conjunction with those financial statements and notes thereon.

SUMMARY STATEMENT OF ASSETS AND LIABILITIES, AS RESTATED

(Rs. In Lakh)

Particulars	As at June,30				
	2002	2003	2004	2005	2006
Fixed Assets (A)					
Gross Block	1236.55	2065.41	2140.35	3003.98	3034.75
Less Depreciation	489.66	572.14	670.18	792.95	937.19
Net Block	746.89	1493.27	1470.17	2211.03	2097.56
Capital Work in Progress	585.45	0.00	604.04	0.00	0.00
Net Block (Total A)	1332.34	1493.27	2074.21	2211.03	2097.56
Investments (B)	1.94	0.00	3.17	3.17	0.00
Current assets , Loans and Advances (C)					
Inventories	841.08	836.86	614.72	1219.40	3978.51
Sundry Debtors	1587.46	3222.40	3788.63	4961.90	8888.05
Cash and Bank Balances	557.99	399.68	1020.86	834.21	1209.96
Loans and Advances	724.22	468.60	276.67	219.92	422.19
Total (C)	3710.75	4927.54	5700.88	7235.43	14498.71
Liabilities and Provisions (D)					
Secured Loans	2212.52	3591.16	3768.47	5274.96	5759.14
Unsecured Loans	0.00	0.00	0.00	0.00	0.00
Current Liabilities and Provisions	1208.90	1055.01	1767.22	1224.64	2977.25
Total (D)	3421.42	4646.17	5535.69	6499.60	8736.39
Networth (A+B+C-D) = (E)	1623.61	1774.64	2242.57	2950.03	7859.88
Represented By					
1. Share Capital	334.56	334.56	334.56	334.56	1054.32
2. Share Application Money Pending allotment	0.00	0.00	0.00	0.00	0.00
2. Reserves	1289.05	1440.08	1908.01	2615.47	6805.56
Networth	1623.61	1774.64	2242.57	2950.03	7859.88
Less: Miscellaneous Expenses	0.00	0.00	0.00	0.00	0.00
Networth	1623.61	1774.64	2242.57	2950.03	7859.88

Note:

1. The fixed assets have not been revalued during any of the period under reporting.



SUMMARY STATEMENT OF PROFITS AND LOSSES, AS RESTATED

(Rs. In Lakh)

	Year ended June,30				
	2002	2003	2004	2005	2006
Income					
Sales :					
Of products manufactured by the Company	4002.21	6054.96	21219.50	29607.75	39445.02
Of products traded in by the Company	881.07	319.31	174.97	83.60	84.05
Total	4883.28	6374.27	21394.47	29691.35	39529.07
Other income	37.96	50.77	36.73	52.26	66.20
	4921.24	6425.04	21431.20	29743.61	39595.27
Expenditure					
Raw Materials consumed	3417.55	4840.05	18690.57	25908.31	34795.68
Staff Costs	262.36	317.99	365.61	385.19	490.80
Other manufacturing expenses	29.57	29.10	37.58	56.93	83.07
Depreciation	58.25	82.48	99.87	128.57	154.82
Administration Expenses	252.47	289.83	445.07	626.23	807.10
Selling and Distribution Expenses	194.19	112.24	358.84	330.63	701.10
Interest	309.53	582.32	907.36	1235.29	1182.11
Total	4523.92	6254.01	20904.90	28671.15	38214.68
Net Profit before tax and extraordinary items	397.32	171.03	526.30	1072.46	1380.59
Prior Period Adjustment	19.60				
Income Tax and FBT	38.64	20.00	58.37	365.00	322.75
Net Profit before deferred tax	378.28	151.03	467.93	707.46	1057.84
Add/Less deferred Tax	0.00	0.00	220.00	113.41	-9.33
Net Profit after adjusting deferred tax	378.28	151.03	247.93	594.05	1067.17



XL TELECOM LIMITED

[The Company was originally incorporated as a Private Limited company under the provisions of the Companies Act, 1956 on 3rd day of October, 1985 as “XL Cable Splices Private Limited” with The Registrar of Companies, Andhra Pradesh at Hyderabad and subsequently the name of the company was changed to “XL Telecom Private Limited” on 16th day of December 1985. The Company was converted to a Public Limited Company by the name of “XL Telecom Ltd” vide fresh Certificate of Incorporation dated 31st December, 1990 obtained from the said Registrar of Companies.]

Registered Office: 335, Chandralok Complex, 111, Sarojini Devi Road, Secunderabad – 500 003

(On incorporation the Registered Office was located at A1/3, Chandralok Complex, Sarojini Devi Road, Secunderabad-500 003, Andhra Pradesh and was changed to 335, Chandralok Complex, Sarojini Devi Road, Secunderabad w.e.f. 18th May, 1987)

Tel.: +91-40-2772 0002, Fax: +91-40-2784 0081

Website: www.xltelecom.net , **Contact Person:** Ms. Ch. Bhavani; **E Mail ID:** chbhavani@xltelecom.net

Registration Number: 01-5844

Registered with the Registrar of Companies, Andhra Pradesh, situated at 2nd Floor, Kendriya sadan, Sultan Bazar Koti, Hyderabad.

GENERAL INFORMATION

BOARD OF DIRECTORS OF THE COMPANY

Sr. No	Name of the Director	Designation
1.	Dr. R Srinivasan	Chairman (Independent)
2.	Mr. Dinesh Kumar	Managing Director
3.	Mr. K Vasudeva Rao	Executive Director
4.	Mr. Aneesh Mittal	Whole Time Director
5.	Mr. Pramod Kumar Jain	Whole Time Director
6.	Mr. Wolfgang Knop	Director (Independent)
7.	Mr. Rajiv Garg	Director (Independent)
8.	Mr. Ashok Kumar Goyal	Director (Independent)
9.	Ms. Ritu Lal Kumar	Director

BRIEF PROFILE OF DIRECTORS:

- Dr R Srinivasan**, aged 75 years is a Doctorate in Banking and Finance, comes with good managerial expertise. He has held several Senior Managerial Positions in the Public Sector Banks like Chairman and Managing Director of Bank of India and Allahabad Bank for several years. He is also associated currently with as Chairman/Director of several companies focussing in Software, Pharma, Gems & Jewellery, Tea, Paint in addition to Mutual Fund Industry.
- Mr Dinesh Kumar**, aged 43 years is the Managing Director of the Company and by qualification he is a B.Com. Graduate. He has been associated with the Telecom Industry for the past 15 years. Mr. Dinesh Kumar joined the Company during the year 1987 as a Management Executive and since then serving the Company. He has been instrumental for the growth of the Company and has been taking care of production, technical and administration of the affairs of the Company. He has knowledge of various telecom products.
- Mr K Vasudeva Rao**, aged 44 years is the Executive Director and is a B.Sc, F.C.A with about 20 years of experience in the Corporate Management. He has held several positions like Executive Director and CEO in Goldstone Technologies Ltd, Executive Director in Goldstone Teleservices Ltd, and several Board positions including few unlisted entities in other countries like Japan and Sri Lanka. He has varied industry exposure like Engineering (Kirloskar Electric), Tea, Telecom and Software. He has been in Telecom Industry for over 13 years focussing Operations and software for over 6 years.
- Mr Aneesh Mittal**, aged 44 years is the Wholetime Director of the company and by qualification is a B.Com graduate. He has over 15 years of experience in the field of Telecom manufacturing Operations. He is rendering services from the inception of the Company in production and assembly of cable jointing kits and other telecom products.
- Mr Pramod Kumar Jain**, aged 40 years is the Wholetime Director of the company and is a Telecom Engineering Graduate. He is having 15 years of experience in the Telecom Industry. He has exposure to various telecom technologies



such as optical transmission, data networking, operation support systems, wireless and mobile communication systems, etc., He has held positions with Companies like Lucent Technologies Pty. Ltd., Singapore, Reliance Telecom Ltd., National Telecom Ltd. and Optel Telecommunications Ltd. in wireless telecommunication.

6. **Mr Wolfgang Knop**, aged 62 years is an Independent Director and is a Chemical Engineer from Berlin University and joined Siemens group in 1976 in cable business. After serving many years in Siemens he was posted as a Director of Sales in the Siemens subsidiary RXS Kabelgarnituren GmbH & Co., KG in the year 1990. He, as Director of Sales was responsible for establishing of RXS brand of products in various countries including India, Japan, Korea and many other countries in Africa. On retirement as Director-Sales of RXS, he was then promoted as Managing Director in RXS in 1995. As the Managing Director he successfully grew the RXS worldwide and RXS become leader in cable accessories. In 1999-2002, he was instrumental in smooth merger of RXS with Corning Cable Systems and continued to be the Managing Director located in Hagen till 2001. In March, 2001, he joined Head quarters of Corning Cable Systems in Munich as a Director on the Board and has been serving since then.
7. **Mr Rajiv Garg**, aged 51 years is Independent Director and has 25 years of experience in finance/general management. Mr. Rajiv Garg is an Engineer from Delhi. After passing Engineering in 1979, he joined State Bank of India and he has worked worked with various Corporate Capital Venture Fund, Jindal Group, Raymonds, etc. Presently he is working as a Corporate Chief Executive Office in ZEE Telefilms Limited.
8. **Mr Ashok Goyal**, aged 49 years, is an Independent Director and is professional Chartered Accountant. He has more than 25 years of experience in managing businesses especially in financial, regulatory issues and more specifically Telecom and Office Automation sectors. He is founder Chairman of Global Advisors Ltd., and was a Partner & Director of Grant Thornton India. He was involved as Executive Director in setting up the first Cellular Network in India for Modi Telestra Ltd.
9. **Ms Ritu Lal Kumar**, aged 41 years is a Graduate by qualification. Smt. Ritu Lal Kumar has been associated with the Company since its inception and with her experience in finance and accounts has been instrumental in computerising the accounts and finance. Earlier she was on the Board and resigned on 25th July, 2002. To benefit from her experience, again she has been inducted as an Additional Director in the Board Meeting held on 21st September, 2002.

COMPANY SECRETARY AND COMPLIANCE OFFICER

Ch. Bhavani

335, Chandralok Complex,
111, Sarojini Devi Road, Secunderabad – 500 003
Tel: +91-40-2772 0002
Fax: +91-40-2784 0081
Email: chbhavani@xltelecom.net

BANKERS TO THE COMPANY

CANARA BANK

R P Road, Secunderabad – 500 003
Tel: +91- 40-2343 8655, 2343 8654
Fax: +91-040-2343 8660
Email: fcssrp@canbank.co.in

VIJAYA BANK

3-1-252/253, SD Road
Secunderabad – 500 003
Tel: +91-40-2784 3436, 2784 7288
Fax: +91-40-2772 2727

INDIAN OVERSEAS BANK

Chandralok Complex, MG Road
Secunderabad – 500 003
Tel: +91-40-2784 7044, 2784 7817
Fax: +91-40-2784 0742

AUDITORS OF THE COMPANY

M/S. SATYANARAYANA & CO.

Chartered Accountants,
Amar Mansion, Ranigunz, Secunderabad – 500 003
Tel no.: +91-40-2771 8992, 2771 5028 Fax no.: +91-40-2771 4814

THE FEDERAL BANK LIMITED

Vasavi Towers, SD Road, Secunderabad – 500 003
Tel: +91-40-2789 6208, 2789 5133
Fax: +91-40-2784 5177
Email: sbd@federalbank.co.in

STATE BANK OF HYDERABAD

Kushaiguda Hyderabad – 500 062
Tel: +91-40-2712 2225
Fax: +91-40-2712 5467
Email: kushaiguda@sbhyd.co.in



ISSUE MANAGEMENT TEAM

BOOK RUNNING LEAD MANAGERS

ANAND RATHI SECURITIES LIMITED

J.K. Somani Building, 3rd Floor, British Hotel Lane,
Bombay Samachar Marg, Fort, Mumbai – 400 023
Tel: +91 22 6637 7000 Fax: +91 22 6637 7070
E-mail: xltl@rathi.com
Website: www.rathi.com
Contact Person: Mr. Paresh Raja

CENTRUM CAPITAL LIMITED

5th Floor, Khetan Bhavan, 198, J Tata Road, Churchgate, Mumbai – 400 020
Tel: +91-22-30280400 Fax: +91-22-22046096
Email: xltelecom@centrum.co.in
Website: www.centrum.co.in
Contact Person: Mr. Mayank Dalal

REGISTRAR TO THE ISSUE

BIGSHARE SERVICES PRIVATE LIMITED

E/2, Ansa Industrial Estate, Saki Vihar Road, Saki Naka, Andheri (E),
Mumbai – 400 072, Maharashtra, India
Tel: +91-22-28473747 Fax: +91-22-28475207
E-mail: bighshare@bom7.vsnl.net.in
Contact Person: Mr. N.V.K. Mohan

LEGAL ADVISORS TO THE ISSUE

V.S. RAJU & ASSOCIATES,

106, Dhanunjaya Towers, Main Road, Banjara Hills, Hyderabad – 500 034.
Tel no.: +91-40-2339 7154 Fax no.: +91-40-2339 8807
Email: xltelecomipo@vsraju.com
Contact Person: Mr. V.B. Raju

SYNDICATE MEMBERS

ANAND RATHI SECURITIES LIMITED

J.K. Somani Building, 3rd Floor, British Hotel Lane, Bombay Samachar Marg, Fort, Mumbai – 400 023
Tel: +91 22 6637 7000 Fax: +91 22 6637 7070
E-mail id: xltl@rathi.com
Website: www.rathi.com
Contact Person: Ms. Meghna Parekh

CENTRUM CAPITAL LIMITED

5th Floor, Khetan Bhavan, 198, J Tata Road, Churchgate, Mumbai – 400 020
Tel: +91-22-30280400 Fax: +91-22-22046096
Email: xltelecom@centrum.co.in
Website: www.centrum.co.in
Contact Person: Mr. Mayank Dalal

Enam Securities Private Limited

Khatau Bldg, 2nd Floor, 44, Bank Street, Fort, Mumbai – 400 023.
Tel: 91 – 22- 2267 7901 Fax: 91 -22 – 2266 5613
Email: ajays@enam.com
Contact Person: Mr Ajay Sheth

BANKERS TO THE ISSUE AND ESCROW COLLECTION BANKERS

CANARA BANK

R P Road, Secunderabad – 500 003
Contact Person: Mr. M. Vijayraj
Tel: +91- 40-2343 8655, 2343 8654 Fax: +91-040-2343 8660
Email: fcssrp@canbank.co.in

**HDFC Bank Ltd.**

26A Narayan Properties, Chandivali Farm Road, Sakinaka,
Andheri (East), Mumbai – 400 059
Contact Person: Mr. Viral Kothari
Tel.: 91-22 – 28569009 Fax: 91-22 – 28569256
Email:viral.kothari@hdfcbank.com

Standard Chartered Bank

Corporate & Institutional Banking
270, D N Road, Fort, Mumbai - 400 001
Contact Person: Mr. Rajesh Malwade
Tel: 91- 22 – 2209 2213 Fax: 91- 22- 2209 6067
Email: rajesh.malwade@in.standardchartered.com

The Hongkong and Shanghai Banking Corporation Limited

52/60, Mahatma Gandhi Road, Fort, Mumbai – 400001
Contact Person : Mr. Zersis Irani
Tel: 91- 22 -2268 5568 Fax: 91- 22- 22623890
Email: zersisirani@hsbc.co.in

Industrial Development Bank of India Limited

IDBI Tower, WTC Complex, Cuff Parade, Mumbai – 400005
Contact Person : Mr. S. Bhaskar Gopal
Tel: 91- 22 - 2218 9111 Fax: 91- 22 – 6655 3355

REFUND BANKER**The Hongkong and Shanghai Banking Corporation Limited**

52/60, Mahatma Gandhi Road, Fort, Mumbai – 400001
Contact Person : Mr. Zersis Irani
Tel: 91- 22 -2268 5568 Fax: 91- 22- 22623890
Email: zersisirani@hsbc.co.in

BROKERS TO THE ISSUE:

All members of Recognised Stock Exchanges would be eligible to act as Brokers to the Issue.

STATEMENT OF INTER-SE ALLOCATION OF RESPONSIBILITIES AMONGST BRLMS

The responsibilities and co-ordination for various activities in this Issue will be complied by the BRLMs to the issue viz. Anand Rathi Securities Limited and Centrum Capital Limited.

Activities	Responsibility	Co-ordinator
Capital structuring with the relative components and formalities such as type of instruments, etc.	Anand Rathi/ Centrum	Centrum
Due diligence of the Company's operations / management / business plans/legal etc.	Anand Rathi/ Centrum	Anand Rathi
Drafting & Design of Draft Red Herring Prospectus and of statutory advertisement including memorandum containing salient features of the Prospectus. Ensure compliance with stipulated requirements and completion of prescribed formalities with SEBI, Stock Exchanges, RoC	Anand Rathi/ Centrum	Anand Rathi
Primary coordination with SEBI, Stock Exchanges and RoC upto bidding and coordinating interface with lawyers for agreement	Anand Rathi/ Centrum	Anand Rathi
Drafting and approval of all publicity material other than statutory advertisement as mentioned above including corporate advertisement, brochure, etc.	Anand Rathi	Anand Rathi
Appointment of Registrar, Bankers, Printer and Ad agency	Anand Rathi	Anand Rathi
Company Positioning and pre-marketing exercise, finalize media and PR strategy	Anand Rathi	Anand Rathi
Qualified Institutional Buyers (QIB): Finalising the list and division of investors for one to one meeting and co-ordinating institutional investors meetings.	Anand Rathi/ Centrum	Anand Rathi



Activities	Responsibility	Co-ordinator
Non Institutional and Retail Marketing of the Issue, which will cover inter alia, <ul style="list-style-type: none"> ● Formulating marketing strategies ● preparation of publicity budget ● Finalizing centres for holding conferences for brokers, etc. ● Finalize collection centres ● Follow-up on distribution of publicity and Issue material including form, prospectus and deciding on the quantum of the Issue material 	Anand Rathi/ Centrum	Anand Rathi
Appointment of Syndicate Members	Anand Rathi/ Centrum	Anand Rathi
Managing the Book, Interaction/Co-ordination with Stock Exchange for book building software, bidding terminals and mock trading	Anand Rathi	Anand Rathi
Finalising pricing, QIB allocation and intimation by BRLMS in consultation with the Company	Anand Rathi	Anand Rathi
Finalization of Prospectus and RoC filing etc.	Anand Rathi	Anand Rathi
Post bidding activities including management of Escrow Accounts, co-ordination with Registrar and Banks, Refund to Bidders, etc.	Anand Rathi/ Centrum	Centrum
The post Issue activities of the Issue will involve essential follow up steps, which include finalisation of listing of instruments and despatch of non institutional allotments advice and related orders, with the various agencies connected with the work such as Registrars to the Issue, Bankers to the Issue and the bank handling refund business.	Anand Rathi/ Centrum	Centrum

CREDIT RATING/ DEBENTURE TRUSTEES:

This being Issue of Equity Shares, appointment of Credit Rating Agency/ Debenture Trustee is not required.

IPO GRADING

Company has not opted for IPO grading.

MONITORING AGENCY

M/s. Canara Bank, R P Road, Secunderabad 500 003 will act as Monitoring Agency.

BOOK BUILDING PROCESS

Book Building Process, with reference to the Issue, refers to the process of collection of Bids from investors, on the basis Price Band. The Issue Price is fixed after the Bid/ Issue Closing Date. The principal parties involved in the Book Building Process are:

1. The Company;
2. The Book Running Lead Managers;
3. The Syndicate Members, who are intermediaries registered with SEBI or registered as a broker with NSE/ BSE and eligible to act as underwriters. The Syndicate Members are appointed by the BRLMS; and
4. The Registrar to the Issue.

The SEBI Guidelines has permitted an issue of securities to the public through the 100% Book Building Process, wherein not more than 50% of the Net Issue shall be allocated on a proportionate basis to QIBs. Out of the portion available for allocation to QIBs, 5% shall be allocated proportionately to mutual funds. Mutual funds shall also be eligible for proportionate allocation under the balance 45% of the Net Issue to the QIBs. Further, not less than 15% of the Net Issue to public shall be available for allotment on a proportionate basis to Non Institutional Bidders and not less than 35% of the Net Issue to Pubic shall be available for allotment on a proportionate basis to Retail Individual Bidders, subject to valid Bids being received at or above the Issue Price.

QIBs are not allowed to withdraw their Bid(s) after the Bid /Issue Closing Date. In addition as per the recent amendments to the SEBI Guidelines, QIBs are required to pay 10% margin amount upon submission of their Bids and the allocation to QIBs will be on a proportionate basis. For further details please see the section titled "Issue Procedure" beginning on page 129.



Our Company shall comply with guidelines issued by SEBI for this Issue. In this regard, our Company has appointed Anand Rathi Securities Limited and Centrum Capital Limited as the BRLMS to manage the Issue and to procure subscription to the Issue.

Illustration of Book Building and Price Discovery Process (Investors may note that this illustration is solely for the purpose of easy understanding and is not specific to the Issue).

Bidders can bid at any price within the price band. For instance, assuming a price band of Rs. 40 to Rs. 48 per share, issue size of 6,000 equity shares and receipt of nine bids from bidders details of which are shown in the table below. A graphical representation of the consolidated demand and price would be made available at the website of the BSE (www.bseindia.com) and NSE (www.nseindia.com). The illustrative book as shown below shows the demand for the shares of the company at various prices and is collated from bids from various investors.

Number of equity shares bid for	Bid Price (Rs.)	Cumulative equity shares bid	Subscription
500	48	500	8.33%
700	47	1,200	20.00%
1,000	46	2,200	36.67%
400	45	2,600	43.33%
500	44	3,100	51.67%
200	43	3,300	55.00%
2,800	42	6,100	101.67%
800	41	6,900	115.00%
1,200	40	8,100	135.00%

The price discovery is a function of demand at various prices. The highest price at which the issuer is able to issue the desired quantum of shares is the price at which the book cuts off i.e. Rs. 42 in the above example. The issuer, in consultation with the BRLMS will finalize the issue price at or below such cut off price i.e. at or below Rs. 42. All bids at or above this issue price and cut-off bids are valid bids and are considered for allocation in respective category.

Steps to be taken for Bidding:

- Check eligibility for making a Bid (see section titled “Issue Procedure - Who Can Bid” beginning on page 130);
- Ensure that you have a demat account and the demat account details are correctly mentioned in the Bid cum Application Form;
- If your Bid is for Rs. 50,000 or more, ensure that you have mentioned your PAN and attached the photocopies of your PAN card to the Bid cum Application Form (see section titled “Issue Procedure - Permanent Account Number” beginning on page 143);
- Ensure that the Bid cum Application Form is duly completed as per instructions given in the Red Herring Prospectus and in the Bid cum Application Form.

Withdrawal of the Issue

Our Company, in consultation with the BRLMs, reserves the right not to proceed with the Issue at anytime after the Bid /Issue Opening Date but before Allotment, without assigning any reason therefore.

Bid/Issue Programme

Bidding /Issue Period

BID/ISSUE OPENS ON	MONDAY, DECEMBER 4, 2006
BID/ISSUE CLOSES ON	THURSDAY, DECEMBER 7, 2006

Bids and any revision in Bids shall be accepted **only between 10 a.m. and 3 p.m.** (Indian Standard Time) during the Bidding Period as mentioned above at the bidding centers mentioned on the Bid cum Application Form except that on the Bid /Issue Closing Date, the Bids shall be accepted **only between 10 a.m. and 1 p.m.** (Indian Standard Time) and uploaded till such time as permitted by the BSE and the NSE on the Bid /Issue Closing Date.



The Company reserves the right to revise the Price Band during the Bidding/Issue Period in accordance with SEBI Guidelines. The cap on the Price Band should not be more than 20% of the floor of the Price Band. Subject to compliance with the immediately preceding sentence, the floor of the Price Band can move up or down to the extent of 20% of the floor of the Price Band advertised at least one day prior to the Bid /Issue Opening Date.

In case of revision in the Price Band, the Bidding/Issue Period will be extended for three additional days after revision of Price Band subject to the Bidding Period/Issue Period not exceeding 10 working days. Any revision in the Price Band and the revised Bidding/Issue Period, if applicable, will be widely disseminated by notification to the BSE and the NSE, by issuing a press release, and also by indicating the change on the web sites of the BRLMS and at the terminals of the Syndicate.

Underwriting Agreement

After the determination of the Issue Price and allocation of our Equity Shares but prior to filing of the Prospectus with the RoC, our Company will enter into an Underwriting Agreement with the Underwriters for the Equity Shares proposed to be offered through this Issue. It is proposed that pursuant to the terms of the Underwriting Agreement, the BRLMS shall be responsible for bringing in the amount devolved in the event that the Syndicate Members do not fulfill their underwriting obligations.

The Underwriters have indicated their intention to underwrite the following number of Equity Shares:

Name and Address of the Underwriter	Indicative Number of Equity Shares to be Underwritten	Amount Underwritten (Rs. Lakh)
Anand Rathi Securities Limited J.K. Somani Building, 3 rd Floor, British Hotel Lane, Bombay Samachar Marg, Fort, Mumbai – 400 023 Tel: +91 22 6637 7000 Fax: +91 22 6637 7070 Email: xltl@rathi.com Contact Person: Mr. Paresh Raja	22,55380	[●]
Centrum Capital Ltd SEBI Regn. No: INU00000076 15 th Floor, Khetan Bhavan, 198, J Tata Road Churchgate, Mumbai – 400 020 Tel: +91 22 3028 0400 Fax: +91 22 2204 6096 Email: xltelecom@centrum.co.in Contact Person: Mr. Mayank Dalal	3,95,681	[●]
Enam Securities Private Limited Khatau Bldg, 2nd Floor, 44, Bank Street, Fort, Mumbai – 400 023. Tel: +91 22 2267 7901 Fax: +91 22 2266 5613 Email: ajays@enam.com Contact Person: Mr. Ajay Sheth	13,05,747	[●]

(This portion has been intentionally left blank and will be filled in before filing of the Prospectus with ROC)

The above Underwriting Agreement is dated [●]

In the opinion of the Board of the Company (based on a certificate given to it by the Underwriters), the resources of all the above mentioned Underwriters are sufficient to enable them to discharge their respective underwriting obligations in full. All the above-mentioned Underwriters are registered with SEBI under Section 12(1) of the SEBI Act or registered as brokers with the Stock Exchanges.

Allocation amongst the Underwriters may not necessarily be in proportion to their underwriting commitments. Notwithstanding the above table, the BRLMS and the Syndicate Member shall be responsible for ensuring payment with respect to Equity Shares allocated to investors procured by them. In the event of any default in payment, the respective Underwriter, in addition to other obligations defined in the Underwriting Agreement, will also be required to procure or subscribe to the extent of the defaulted amount. Allocation to QIBs may not be proportionate in any way and the patterns of allocation to the QIBs could be different for the various Underwriters.



CAPITAL STRUCTURE

The Share Capital Structure of our Company as on date of filing this Red Herring Prospectus with SEBI is as below:

(Rs. In Lakhs)

	Share Capital as on date of filing this Red Herring Prospectus	Nominal Value	Aggregate Value
A.	Authorised Share Capital		
	2,00,00,000 Equity Shares of Rs.10/- each	2000.00	
B.	Issued, Subscribed and Paid Up Capital before the Issue		
	105,43,192 Equity Shares of Rs. 10/- each fully paid up.	1054.32	
C.	Present Issue to the Public in terms of this Red Herring Prospectus		
	39,56,808 Equity Shares of Rs. 10/- each at a Premium of Rs. [●] each		
	Out of which		
	1,76,808 Equity Shares are reserved for the Eligible Employees of the Company	17.68	[●]
	37,80,000 Equity Shares is the Net Issue to the Public	378.00	[●]
	Of which:		
	Qualified Institutional Buyers upto 18,90,000 Equity Shares (5% thereof reserved to be allocated for Mutual Funds)	189.00	[●]
	Non-Institutional Portion of atleast 5,67,000 Equity Shares	56.70	[●]
	Retail Portion of atleast 13,23,000 Equity Shares	132.30	[●]
D.	Subscribed And Paid Up Capital After The Issue		
	1,45,00,000 Equity Shares of Rs. 10/- each fully paid up.	1450.00	[●]
E.	SHARE PREMIUM AMOUNT		
	- Before the Issue	3609.40	
	- After the Issue	[●]	

Notes:

- Originally the Equity Shares are of the face value of Rs.100/-each and subsequently subdivided into the face value of Rs. 10/- each vide the resolution passed in the Extra-ordinary General Meeting held on 9th March, 1992
- Company has thrice issued bonus shares to the shareholder in the past by capitalization of profits of the company. 27,544 Equity Shares allotted on 16th September, 1989 and 31,181 Equity Shares allotted on 19th January, 1991. On March 3, 2006 Company again issued 47,71,596 shares as bonus shares to the eligible shareholders in the ratio of 1:1.
- Company has allotted 14,26,000 shares to various shareholders @Rs.200 per share including Rs.190 as premium per share on a preferential basis on 1st Feb, 2006.
- Company has allotted 10,00,000 shares to a Venture Capital Firm @Rs.100 per share including Rs.90 as premium per share on a preferential basis on 5th May, 2006.

Notes Forming Part of the Capital Structure

- Details of increase in Authorised Share Capital of the Company after the date of incorporation till filling of the Red Herring Prospectus with SEBI is as follows

Sr. No.	Particulars of the Increase	AGM/ EGM	Date of Meeting
1	Rs. 5,00,000	Incorporation	Incorporation
2	Rs.15,00,000	EGM	05-05-1986
3	Rs.25,00,000	EGM	23-07-1987
4	Rs. 50,00,000	EGM	13-03-1989
5	Rs. 1,00,00,000	AGM	10-07-1989



Sr. No.	Particulars of the Increase	AGM/ EGM	Date of Meeting
6	Rs.3,00,00,000	AGM	29-10-1990
7	Rs.3,50,00,000	AGM	20-06-1991
8	Subdivision of Shares of Rs. 100/- to Rs. 10/- each	EGM	09-03-1992
9	Rs. 7,00,00,000	EGM	09-03-1992
10	Rs.20,00,00,000	EGM	27-01-2006

2. Share Capital History of the Company

Date of allotment/ Reduction	No. of Shares	Face Value (Rs.)	Issue Price (Rs.)	Value (Rs.)	Cumulative Paid-up Capital (Rs.)	Consideration (Cash, Bonus, kind etc.)	Remarks
Subscription	2	100	100	200	200	Cash	Shares taken by Subscribers to the Memorandum and Articles of Association
05-05-1986	4998	100	100	499800	500000	Cash	Allotment
29-09-1986	5000	100	100	500000	1000000	Cash	Allotment
01-09-1988	7000	100	100	700000	1700000	Cash	Allotment
31-03-1989	28907	100	100	2890700	4590700	Cash	Allotment
16-09-1989	27544	100	100	2754400	7345100	Bonus	Allotment
30-03-1990	4503	100	100	450300	7795400	Cash	Allotment
23-10-1990	12440	100	100	1244000	9039400	Cash	Allotment
10-12-1990	8978	100	100	897800	9937200	Cash	Allotment
19-01-1991	31181	100	100	3118100	13055300	Bonus	Allotment
29-05-1991	1295	100	100	129500	13184800	Cash	Allotment
22-11-1992	32820	10	10	328200	13513000	Cash	Allotment
03-12-1992	1000000	10	10	10000000	23513000	Cash	Allotment to IDBI, ICICI, IFCI
24-07-1992	494296	10	10	4942960	28455960	Cash	Allotment to Collaborator*
17-08-1992	419098	10	10	4190980	32646940	Cash	Allotment to Collaborator*
11-02-1993	80902	10	10	809020	33455960	Cash	Allotment to Collaborator*
01-02-2006	1426000	10	200	14260000	47715960	Cash	Allotment to Investors
03-03-2006	4771596	10	10	47715960	95431920	Bonus	Allotment
05-05-2006	1000000	10	100	10000000	105431920	Cash	Allotment to Investors

*Name of the Collaborator "RXS Schrumpftechnik Garnituren GmbH, a 100% Subsidiary of SEIMENS.

3. Shares Issued for Consideration other than Cash

The Company has not issued any shares for consideration other than cash excepting Bonus shares issued from time to time by capitalization of Reserves.

4. As on the date of filing of this Red Herring prospectus with SEBI, the issued capital of the Company is fully paid-up.



5. Promoters Contribution and Lock-in Period:

The following shares shall be locked in for a period of three years being part of promoter's contribution:

Name	Date of Acquisition	Consideration	No. of Shares	Face Value (Rs.)	Issue / Acquisition Price	% of post Issue Capital	Lock-in Period
Mr. Dinesh Kumar	01-10-2003	Cash	1223	10	10	0.01%	3 Years
	27-01-2004	Cash	126	10	10	0.00%	3 Years
	24-07-2004	Cash	165716	10	23.13	1.14%	3 Years
	09-11-2004	Cash	81432	10	23.13	0.57%	3 Years
	07-02-2005	Cash	165716	10	23.13	1.14%	3 Years
	20-05-2005	Cash	165716	10	23.13	1.14%	3 Years
	06-10-2005	Cash	165716	10	23.13	1.14%	3 Years
	03-03-2006	Bonus	745645	10	Nil	5.14%	3 Years
			1491290			10.28%	
Smt. Snehlata Lal Family Welfare Trust	23-08-2001	Cash	64795	10	5.90	0.45%	3 Years
Smt. Snehlata Lal Family Welfare Trust	03-03-2006	Bonus	1343915	10	Nil	9.27%	3 Years
			1408710			9.72%	
	Total		2900000			20.00%	3 Years

Note:

- All the above shares of Mr. Dinesh Kumar, Managing Director are acquired by way of transfer from others and by way of bonus. Further all the above shares of Mr. Dinesh Kumar are in Demat form.
- Similarly all the above shares of M/s. Snehlata Lal Family Welfare Trust are acquired by way of transfer from Late Mr Sunder Lal, the founder of the company and Late Mrs Snehlata Lal.

The promoter's contribution has been brought in to the extent of not less than the specified minimum lot and from persons defined as promoters under the Guidelines.

The lock in period shall commence from the date of Allotment of shares in the present Public Issue

6. Balance of Promoters Contribution shall be Locked-in as follows:

Name	Date of Acquisition	Consideration	No. of Shares	Face Value (Rs.)	Issue / Acquisition Price	% of post Issue Capital	Lock-in Period
Smt. Snehlata Lal Family Welfare Trust	20-06-1996	Cash	3417	10	10	0.02%	1 Year
	25-09-1996	Cash	1530	10	10	0.01%	1 Year
	26-08-1997	Cash	60	10	10	0.00%	1 Year
	17-10-1997	Cash	220	10	10	0.00%	1 Year
	28-12-1998	—	158320	10	Nil	1.09%	1 Year
	05-12-2000	Cash	339795	10	10	2.34%	1 Year
	23-08-2001	Cash	464545	10	5.90	3.20%	1 Year
	31-01-2002	—	311233	10	Nil	2.15%	1 Year
			1279120			8.82%	



The lock-in period shall commence from the date of Allotment of shares in the proposed Public Issue.

The Company confirms that the minimum Promoter contribution of 20% which is subject to lock-in for three years does not consist of:

- a) Shares acquired for consideration other than cash and revaluation of assets or capitalization of intangible assets or bonus shares out of revaluation reserves or reserves without accrual of cash resources.
- b) Securities issued during the preceding one year, at a price lower than the price at which equity shares are being offered to public.
- c) Private placement made by solicitation of subscription from unrelated persons either directly or through any intermediary.
- d) Shares for which specific written consent has not been obtained from the respective shareholders for inclusion of their subscription in the minimum promoter's contribution subject to lock-in.
- e) Shares issued to promoters on conversion of partnership firms into limited company.
- f) Shares with a contribution less than Rs.25,000/- per application from each individual and contribution less than Rs.1,00,000/- from firms and companies.

29,00,000 Equity Shares constituting 20.00% of the post issue share capital of the promoters would be locked-in for a period of 3 years. The lock in shall start from the date of allotment in the proposed public issue and the last date of the lock in shall be reckoned as 3 years from the date of allotment in the public issue. Balance entire pre-issue share capital of Promoters consisting of 12,79,120 Equity Shares of Smt. Snehlata Lal Family Welfare Trust shall be locked in for the period of 1 year.

The locked-in Equity Shares held by the Promoter(s) can be pledged only with banks or financial institutions as collateral security for loans granted by such banks or financial institutions, provided the pledge of Equity Shares is one of the terms of sanction of such loan.

Equity Shares held by Promoter(s) which are locked in as per the relevant provisions of Chapter IV of the SEBI Guidelines, may be transferred to and amongst Promoter/Promoter group or to a new promoter or persons in control of our Company, subject to continuation of lock-in in the hands of transferees for the remaining period and compliance of Securities and Exchange Board of India (Substantial Acquisition of Shares and Takeovers) Regulations, 1997, as applicable.

Balance of entire pre-issue Equity Shares capital held by person other than Promoters of the company shall be locked in for the period of 1 year.

Equity Shares held by the person other than the Promoters, prior to this Issue, which are subject to lock in as per the relevant provisions of Chapter IV of SEBI Guidelines, may be transferred to any other person holding Equity Shares which are locked in, subject to continuation of lock-in in the hands of transferees for the remaining period and compliance of Securities and Exchange Board of India (Substantial Acquisition of Shares and Takeovers) Regulations, 1997 as applicable.

7. Transactions in our Company's Equity Shares by Promoters/Promoter Group and the Directors of Company during a period of six months preceding the date of filing of this Red Herring Prospectus with SEBI

There has been no sale or purchase in Company's Equity Shares by the Promoters/Promoter Group and the Directors of our Company during a period of six months preceding the date of filing of this Red Herring Prospectus with SEBI.

8. The Company has issued bonus shares and the particulars of them are as follows:

Date of allotment	No. of Shares	Face Value (Rs.)	Nominal Value (Rs.)	Cumulative Paid-up Capital (Rs.)	Remarks
16-09-1989	27544	100	2754400	2754400	3 shares for every 5 shares
19-01-1991	31181	100	3118100	5872500	2 shares for every 5 shares
03-03-2006	4771596	10	47715960	95431920	1 Share for every 1 Share

Equity Shares of face value of Rs. 100/- above have been subdivided into the Equity Shares of face value of Rs. 10/- each in the Extra-ordinary General Meeting held on 09-03-1992 and fresh share certificate have been issued on 10th April, 1992



9. Top Ten Shareholders

(A) Particulars of top ten shareholders as on the date of filing this Red Herring Prospectus with RoC

Sr. No.	Name of the Shareholder	No. of Shares (of Rs.10/- each)
1.	Snehlata Lal Family Welfare Trust	26,87,830
2.	Dinesh Kumar	14,91,290
3.	Businessmatch Services (India) Private Limited	10,00,000
4.	2i Capital PCC	10,00,000
5.	ICICI Trusteeship Services Limited	5,00,000
6.	IFCI Limited	5,00,000
7.	Volrado Venture Partners	5,00,000
8.	Mounteverest Trading and Investment Limited	3,00,000
9.	WHF Precisions Forgings Limited	3,00,000
10 (i).	Aavishkar Securities Private Limited	2,40,000
10 (ii).	Bluegold Securities Private Limited	2,40,000
10 (iii).	Apurve Tie Up Private Limited	2,40,000

(B) Particulars of top-ten shareholders 10 days prior to the date of filing this Red Herring Prospectus with RoC

Sr. No.	Name of the Shareholder	No. of Shares (of Rs.10/- each)
1.	Snehlata Lal Family Welfare Trust	26,87,830
2.	Dinesh Kumar	14,91,290
3.	Businessmatch Services (India) Private Limited	10,00,000
4.	2i Capital PCC	10,00,000
5.	ICICI Trusteeship Services Limited	5,00,000
6.	IFCI Limited	5,00,000
7.	Volrado Venture Partners	5,00,000
8.	WHF Precisions Forgings Limited	3,00,000
9.	Mounteverest Trading and Investment Limited	3,00,000
10 (i).	Aavishkar Securities Private Limited	2,40,000
10 (ii)	Bluegold Securities Private Limited	2,40,000
10(iii)	Apurve Tie Up Private Limited	2,40,000

(C) Particulars of Top-Ten shareholders Two Years prior to date of filing this Red Herring Prospectus with RoC.

Sr. No.	Name of the Shareholder	No. of Shares(of Rs.10/- each)
1.	Snehlata Lal Family Welfare Trust	13,43,915
2.	Corning Cables Systems GmbH & Co., KG	6,62,864
3.	Industrial Development Bank of India	5,00,000
4.	IFCI Limited	2,50,000
5.	ICICI Trusteeship Services Limited	2,50,000
6	Dinesh Kumar	1,67,065
7.	The Federal Bank Limited	1,65,716
8.	Mrs. Mala Srivastav	940
9.	Yeshwant Kumar	530
10(i).	Keki F Byramji	490
10(ii).	K Vasudeva Rao	490



10. Shareholding Pattern of our Company- Pre and Post Issue

Sr. No.	Category	Pre- Issue Equity Capital		Post Issue Equity Capital	
		No. of Shares	% of holding	No. of Shares	% of holding
A.	Promoter's Holding				
1	Promoters				
	- Indian Promoters	41,79,120	39.64%	41,79,120	28.82%
	- Foreign Promoters	—	—	—	—
2	Persons acting in concert**	48,64,072	46.13%	48,64,072	33.55%
	Sub-Total	90,43,192	85.77%	90,43,192	62.37%
B.	Non-Promoter holding				
1	Institutional Investors	—	—	—	—
a.	- Mutual Funds and UTI	—	—	—	—
b.	- Central/ State Govt. Institutions/ NGO	—	—	—	—
c.	- FIIs	—	—	—	—
2	Others				
a.	- Private Corporate Bodies	—	—	—	—
b.	- Public	—	—	37,80,000	26.07%
c.	- Employees	—	—	1,76,808	1.22%
d.	- OCBs	—	—	—	—
e.	-SEBI Registered Venture Capitalists	15,00,000	14.23%	15,00,000	10.34%
	GRAND TOTAL	105,43,192	100.00%	1,45,00,000	100.00%

** The above Persons acting in concert do not qualify as part of the Promoters / Promoters Group as per the Explanation II of Clause 6.8.3.2 (m) of the SEBI (DIP) Guidelines. They have been classified as Persons Acting in Concert in the above table as stipulated by BSE while granting in-principle approval for listing. They are not PAC's / qualify as PAC's for any other purpose like compliance with SEBI (Substantial Acquisition of Shares and Takeovers) Regulations, 1997 and amendments thereto.

NOTES:

1. The Company/Promoters/Directors/ Book Running Lead Managers to this issue have not entered into buyback/standby or similar arrangements for purchase of Equity Shares of our Company from any person.
2. The Shareholders of the Company do not hold any warrant, options, convertible loan or any debenture, which would entitle them to acquire further shares of the Company. The locked in shares have been pledged with IDBI Bank, the details of which are as follows:

Name of the Promoter	No. of shares Pledged	Date of Pledge	Facility availed of	Terms & conditions of Pledge
Smt. Snehlata Lal Family Welfare Trust	8,14,575	19.02.2002	Rs. 1000.00 Lakh	Pledged as security for repayment of the facility sanctioned by IDBI.

3. In case of under subscription in the reserved category, the same shall be added back to the net issue to the public. In case of over subscription in the reserved category, excess shall be made from shortfall if any, in the Retail and Non-Institutional category (i.e shortfall in the retail or non-institutional category shall be first adjusted against excess demand in the non-institutional or retail category respectively and the balance shortfall if any, shall be available to the reserved category).
4. In the case of over-subscription in all categories, upto 50% of the Net Issue to Public shall be allocated on a proportionate basis to Qualified Institutional Buyers, of which 5% shall be reserved for Mutual Funds. Further, not less than 15% of the Net Issue to Public shall be available for allocation on a proportionate basis to Non Institutional Bidders and not less than 35% of the Net Issue to Public shall be available for allocation on a proportionate basis to Retail Individual Bidders,



subject to valid bids being received at or above this Issue Price. Under-subscription, if any, in any of the categories would be allowed to be met with spill over from any other category at the sole discretion of our Company in consultation with the BRLMS. In case of inadequate demands from the Mutual Funds, the Equity Shares would be made available to QIBs other than Mutual Funds.

5. Only Eligible Employees would be eligible to apply in this issue under Employee Reservation Portion on a competitive basis. Separate bid-cum-application Forms can be submitted by Eligible Employees under the Net Issue to Public category as well and such bids will not be treated as multiple bids. The un-subscribed portion, if any, out of the Equity Shares reserved for allotment to Eligible Employees of our Company will be added back to the Net Issue to Public.
6. The un-subscribed portion, if any, after such inter-se adjustments amongst the reserved categories shall be added back to the Net Issue to Public. And in case of under-subscription in the Net Issue to Public portion, spill over to the extent of under-subscription shall be permitted from the reserved category to the Net Issue Portion.
7. A Bidder cannot make a Bid for more than the number of Equity Shares offered through this Issue, subject to the maximum limit of investment prescribed under relevant laws applicable to each category of investor.
8. The Company has not issued any shares out of revaluation reserves or for consideration other than cash, except for the shares issued by way of bonus as mentioned under the Share Capital History of the Company.
9. There shall be only one denomination of the Equity Shares of the Company, unless otherwise permitted by law. The Company shall comply with disclosure and accounting norms as may be specified by the SEBI from time to time.
10. The Company has 59 shareholder members as on the date of filing the Red Herring Prospectus with SEBI.
11. Specific written consents have been obtained from Promoter(s)/ Promoter Group for inclusion of their securities as part of Promoter/Promoter Group subject to lock-in.
12. The Company have not availed of any bridge loans against the proceeds of the Issue.
13. Our Company has not revalued its assets since inception.
14. Our Company has not made any public issue since its incorporation.
15. An over-subscription to the extent of 10% of the Net Issue to Public can be retained for the purpose of rounding off to the nearest integer while finalising the Basis of Allotment.
16. There would be no further issue of capital whether by way of issue of bonus shares, preferential allotment, and rights issue or in any other manner during the period commencing from submission of this Red Herring Prospectus with SEBI until the Equity Shares offered through this Red Herring Prospectus have been listed.
17. We presently do not have any intention or proposal to alter our capital structure for a period of six months from the date of opening of this Issue, by way of split/ consolidation of the denomination of Equity Shares or further issue of Equity Shares (including issue of securities convertible into exchangeable, directly or indirectly, for our Equity Shares) whether preferential or otherwise, except that if we enter into acquisitions or joint ventures, we may consider raising additional capital to fund such activity or use Equity Shares as currency for acquisition or participation in such joint ventures.
18. Allotment of Equity Shares to Promoters/ Promoter Group Companies and other persons at a price lower than the Issue Price to be discovered through book building in this Issue.

We have made the allotments of Equity Shares to following persons and the price of such issues may be lower than the Issue Price:

Date	Number of Shares	Face Value	Issue Price	Details
05-05-2006	2i Capital Pcc	10	100	Allotment @Rs. 100/- per share

19. Equity Shares issued for consideration other than cash or out of revaluation reserves are as follows:

Date of Issue	No. of Shares	Issue Price (in Rs.)	Reasons for issue	Benefits accrued to the Company
16-09-1989	27544	NIL	Bonus	N.A.
19-01-1991	31181	NIL	Bonus	N.A.
03-03-2006	4771596	NIL	Bonus	N.A.



OBJECTS OF THE ISSUE

The Company proposes the Present Issue of Equity Shares to:

1. Fund the Capital Expenditure for Expanding the Module Making capacity of Solar Photovoltaic (SPV) Division
2. Setting up of facilities for Surface Mounting Technology (SMT) Lines to produce the PCB's used in the Mobile Phones
3. Repayment of Term Loans
4. Long Term Working Capital requirement for Fixed Wireless Phone(FWP) Business
5. Meet the Expenses of the Issue
6. List the Equity Shares of the Company on BSE and NSE.

The main objects clause and objects incidental or ancillary to the main objects clause of the Memorandum of Association of the Company enables the Company to undertake the existing activities and the activities for which the funds are being raised through the present Issue. The Company further confirms that the activities of Company carried out until now are in accordance with the objects of the Memorandum of Association of the Company.

Funds Requirement

The Company has estimated funds requirement as under:

(Rs in Lakhs)	
Particulars	Amount
1. Expansion of SPV Module Making Plant (SPV Division)	800.00
2. Creation of SMT Line to produce PCB's used for CDMA Mobile and FWP Phones	2040.00
Total Capital Equipment	2840.00
3. Repayment of IDBI Term Loan	900.00
4. Long Term Working Capital for FWP Business (deferred Payment Model of BSNL)	2000.00
5. Issue Expenses	[●]
Total Funds Requirement	[●]

Means of Finance

The entire requirement of the funds for the Capital Expenditure is proposed to be funded through proceeds of the Issue. In case of any shortfall in the means of finance or cost escalation in the Expansion Project, the same shall be met by the promoters of the Company. Excess money, if any, will be utilized for general corporate purpose.

Rs in Lakh	
Particulars	Amount
1. Public Issue of Equity Shares	[●]
2. Internal Accruals	[●]
Total	[●]

In case of excess money, if any, the same will be utilized for general corporate purpose including but not restricted to repayment of existing working capital loans. The proposed Project has not been appraised by external agencies and as such all the fund requirements are based on management estimates.

The Company has been generating profits for last several years and has not utilized the same towards payment of Dividend and has retained with in the company for the growth of the Company. Company has generated for the year 2005-06 a Net Profit of Rs.1085 Lakh and Cash Profit of Rs.1200 Lakh, which can be utilized for the expansion as internal accruals, in case of short fall in the IPO Funds.

Appraisal

The proposed project has not been appraised by any external agency and as such all the funds requirements are based on Management estimates and approved by Board of Directors.



Capital Expenditure:

Expansion of Module Making Capacity to 24 MW in the SPV Division: (Rs. 800 Lakh)

XL is into manufacturing of Solar Photovoltaic systems in India for over a decade. The Company has supplied order worth of Rs.2800 Lakhs within first 12 months of creation of new division. XL had created the facility with a meagre capital investment of less than Rs. 200 Lakhs in the year 1994 and has a very low capacity of 1 MW per annum. XL has been supplying several solar systems to BSNL (erstwhile DoT), several Nodal agencies of IREDA and Exports to international markets.

Last one year there is export opportunity in the Solar Photovoltaic division especially from Europe. Couple of Countries in Europe has made it mandatory to have about 160 Watt to 200 Watt solar power generation for every home. All the home owners need to create this in the next 2 years in view of mandatory directions, which has created demand for SPV Products.

Realizing the immediate opportunity, XL has established an MOU with a supplier of SPV systems in Europe for supply of these systems. MOU entered with this European company speaks of potential immediate order for 3 MW valued over US \$ 13 Million.

These opportunities necessitated immediate expansion of the Module making capacity of the SPV Division from the existing 1 MW per annum to about 24 MW per annum with a capital outlay of Rs. 800 Lakhs.

The Company has already identified the potential suppliers and have received the quotations and issued purchase orders so that the Company receives the equipment after the lead time of about 3 months. Company expect the proposed project to be completely ready by Mar 2007 and effecting the first supply immediately thereafter in May 2007.

The Company has in-house established technology and competency in both handling the business and production.

The facility will be established in the existing facility at Mallapur near Hyderabad in Andhra Pradesh.

SN	Supplier	Equipment	Model	Qty	Price	Taxes	Total	PO No
					(Rs Lakh)			
1	Spire Corporation	Photovoltaic Module Tester	460i	2	95.38	5.72	202.2	SPV-CAP-5385/ 10.03.2006
2	Spire Corporation	Solar Cell Tester	Cell Test 150	1	72.61	4.36	76.97	SPV-CAP-5384 10.03.2006
3	HHVC	Vacuum Laminator	VL-4	6	30	6.29	217.75	SPV-CAP-5393 31.03.2006
4	HHVC	Vacuum Laminator	VL-4	6	30	6.29	217.75	SPV-CAP-5394 04.03.2006
5		Furniture & Fixtures					20.00	Orders to be placed
6		Building Modification to suit equipment					20.00	Work order to be issued
7		Contingencies including fluctuation in FC @6%					45.33	
		Total Cost of Solar Project					800.00	

Creation of New SMT Line to produce PCBs for usage in Mobile Phones and FWP's (Rs 2040 Lakh)

XL has been focussing in Mobile Phone Segment for the last five years and this focus has given growth in revenues of the company. XL achieved revenues of about Rs.33674 Lakhs in the year 2005-06 in this segment alone. XL has currently established only "ASSEMBLY" facility for manufacture of Mobile Phones in partnership with KYOCERA.

XL has similarly established partnership with AXESSTEL of US for Fixed Wireless Phones. Company has participated in the tender of BSNL for supply of these Fixed Wireless Phones in the last year. XL has received an order for supply of these phones valued over Rs.9600 Lakhs in the Month April 2006. XL has supplied part of this order during the financial year 2005-06 and the remaining portion of the order is under execution.

Looking at the opportunities in these two product lines, company has decided to increase the percentage of manufacturing in India and thereby improve the value addition with in the country for these products and be cost competitive. Hence XL has decided to establish of Assembly Line for manufacture of mother boards (PCB's) based on Surface Mount Technology for emerging and growing Fixed Wireless Phones and CDMA Phones to increase the value addition and also to reduce the dependency on collaborators.



The SMT line facility is expected to involve about Rs.2040 lakhs for a capacity of 2 Million phones per annum. The Machinery will be installed in the existing facility of 25,000 sq ft building located in the Cherlapalli factory.

XL will continue to depend on the partners for the products, design and development, including the brand in the foreseeable future. XL has no intention to invest in the huge R&D in product development and brand creation. Hence, XL proposes to work with partners and source all the components even after installing the said SMT Line, While it could mean marginal cost advantage of about \$2 per phone in the increased manufacturing activity, which should add to the bottom line.

Mobile & Fixed Wireless phone Manufacturing Line					
Capacity 2.0 Million per year.					
A. SMT Manufacturing and AOI Testing infrastructure					
Manufacturer	Model	Description	Unit Price US\$	Qty	Total Price US \$
Nutek	NTM0100LL	Automatic Loader with	12250	1	12250
		Magazines	315	5	1575
MPM	Accuflex	Fully Automatic Screen Printer	108500	1	108500
Nutek	NTM0501-L	Inspection Conveyor	2975	1	2975
		Sub-total			125300
		NXT Configuration			
Fuji	NXT	M3Sx12 (H12Sx10+H08x1+H04x1)		12	
Fuji	NXT	M6x2 (H04x1+H01x1)		2	
	W8	Intelligent Feeder w/o reel holder		150	
	W12	Intelligent Feeder w/o reel holder		10	
	W16	Intelligent Feeder w/o reel holder		2	
	W24	Intelligent Feeder w/o reel holder		2	
	W32	Intelligent Feeder w/o reel holder		2	
	W44	Intelligent Feeder w/o reel holder		2	
	Stick Feeder	Vibratory Stick Feeder		8	
		Sub-total NXT Price with all Accessories			943530
Agilent	SJ50 Series II	Automated Optical Inspection	136500	1	136500
Nutek	NTM1100TL	90 Degrees Turn Conveyor	8750	1	8750
Nutek	NTM0501-L	Inspection Conveyor	2975	1	2975
Camalot	XYFlex Pro	Underfill machine	129500	1	129500
Electrovert	Omniflex10	Reflow	119000	1	119000
Nutek	NTM0501-L	Inspection Conveyor	2975	1	2975
Electrobit	Flarc J005 - III	Robotic Test Handler for Flash program	108500	1	108500
Electrobit	J501-44	High Speed Router	101500	1	101500
		Sub-total			609700
		Total equipment Price			1678530



B. AUTOMATIC OPTICAL INSPECTION SYSTEM (AOI) – SJ-50 Series 2

Manufacturer	Model	Description	Unit Price	Qty	Total Price
Agilent	SJ-50 SII	Machine(two for two lines)–Basic system			
		N5065-SJ50 Series II AOI Value System Includes 510 X 510 mm Board size, Pre Reflow & post Reflow SW, 2D PasteSW, OCR SW		2	
		AOI UPS with Power Cables (UPS is provided only for AOI PC)		2	
		Power Option- 230V/16A		2	
		Conveyors Selection		2	
		Single Lane System Conveyor, Left to Right & Front Fixed		2	
		ART Solution		2	
		ART (Agilent Repair Tool) — Client Licence		2	
		AQT (Agilent Quality Tool) — Viewer License		2	
		Basic spares kit		2	
		Basic kit for Auto Adjust system conveyor		2	
		Warranty -1 year Co-operative with parts 5x8, Including installation		2	
		1 year SW updates, CD-ROM,License to use for AOI System		2	
		AOI System on Site Consulting Package		2	
		Sub-total Basic system	126000	2	252000
Agilent		One Time Purchase for above 2 machine			
		ITF Server			
		SJ50 Level 2 spares Kit			
		Auto-Adjust Advanced Conveyor Spares Kit			
		Fiducial Calibration Plate			
		Offline Programming with CAMCAD			
		Sub-total One Time Purchase items	20619	1	20619
		Total equipment Price			272619

C. Testing and Calibration Facility

Basic Functions	Board Level Testing, RF Calibration, Repair, ESN Programming, Final Assembly QA Testing, Software down load				
Manufacturer	Model	Description	Unit Price	Qty	Total Price
Agilent		GS8000 systems required (2UP for Cal, 2UP for FT and 1UP for QA)	76974	19	1462503
Summary	US \$				
Total cost of equipment				3413652	
* Freight & Insurance				2.00%	68273
* Custom Duty and clearance				18.00%	614457
* Installation and commissioning				4.00%	136546
* Line and IT set-up					300000
					4532929
Conversion in to Indian Rupees @45				Rs.	2040 Lakh



Orders have been placed for the above Project except in the case of Line and IT set-up which will be placed on installation of the Equipment:

Vendor	Purchase Order No.	US \$
Agilent Technologies – Singapore	SMT-CAP-1240/05-06 dt 5.3.2006	425,484
Agilent Technologies – Singapore	SMT-CAP-1241/05/06 dt 5.3.2006	1,521,003
Agilent Technologies – Singapore	SMT-CAP-1245/05/06 dt 5.3.2006	283,524
M/s Fuji Machine Mfg – Singapore	SMT-CAP-1242/05/06 dt 5.3.2006	1,014,031
M/s Speedline Technologies Inc – Singapore	SMT-CAP-1243/05/06 dt 5.3.2006	371,280
M/s. JOT Automobiles Ltd – Finland	SMT-CAP-1244/05/06 dt 5.3.2006	218,400

Repayment of Term Loans:

XL had Outstanding Term Loans of Rs. 900.00 Lakhs as at 31.1.2006 to IDBI, which is proposed to be prepaid and thereby reduce the Interest burden on the Company and the balance outstanding out of the the same as at 30.06.2006 is Rs.800 Lakh.

Term Loans Proposing to be repaid from IPO proceeds

Particulars of Loan	Bank	Nature of Loan	Sanctioned Amount (Rs. In Lakhs)	Outstanding on 31.1.06 (Rs. In Lakhs)	Rate of Interest P.A.	Repayment of Terms	Securities offered
Term Loan	IDBI	Term Loan-2	1000	900(outstanding as at 30 th June 2006 is Rs.800 Lakh)	2.00%	October 2005 to 1 July 2010 Rs. 50 Lakh per Quarter (20 installments)	1st Pari Passu Charge on Fixed Assets of SMPS and Unexpanded Profile and 1st Pari Passu Charge on current Assets of the company & Equity Shares held the Trust

Working Capital for deferred payment model of BSNL Sales in new FWP Business: Rs. 2000 lakhs

Further XL has diversified in to Fixed Wireless Phone segment in the Telecom Sector. XL has associated itself with international FWP manufacturer and NASDAQ listed entity M/s. Axestel. XL has participated in the Tender floated by India's largest service provider M/s. BSNL for supply of these FWP's and has got an order valued over Rs.9600 Lakhs. As per the terms of the Tender Conditions, 20% of payment will be paid after 12 months of delivery of the materials. In view of regular procurement plans of BSNL and XL's continued interest in this product segment, XL will need long term working capital need of 20% of these potential revenues, which on the current order opportunity works out to Rs.2000 Lakhs.

Expenses of the Issue

The expenses for this Issue include lead management fees, selling commissions, printing and distribution expenses, legal fees, advertisement expenses, registrar fees, depository charges and listing fees to the Stock Exchanges, among others. The total expenses for this Issue are estimated to be approximately Rs. [●] Lakh, which is [●] % of the issue size.

All the Issue related expenses shall be met out of the proceeds of the Issue and the break-up of the same is as follows:

Particulars	Expenses	As a % of the Issue size
Management fees, underwriting commission and brokerage	[●]	[●]
Marketing and advertisement expenses	[●]	[●]
Stationary, printing and registrar expenses	[●]	[●]
Legal fees, listing fees, book building charges, auditors fees	[●]	[●]
Miscellaneous	[●]	[●]
Total	[●]	[●]

Appraisal

Company's fund requirements and deployment thereof are based on internal management estimates, and have not been appraised by any bank or financial institution. In case of any variations in the actual utilization of funds earmarked for the above activities, increased fund deployment for a particular activity may be met with by surplus funds, if any available in respect of the other activities or from the internal accruals.



Schedule of Implementation:

Activity	Commencement date	Completion date
Expansion of SPV Module Making Plant (SPV Division)		
Modification of existing Building	July 2006	Oct 2006
Purchase of Furniture & Fixtures	Dec 2007	Jan 2007
Placement of Order for Machinery	April 2006	
Delivery of Machinery	Sept 2006	Dec 2006
Installation of Machinery	Oct 2006	Dec 2006
Trial Production	Jan 2007	
Commercial Production	Jan 2007	
Creation of SMT Line to produce PCB's used for CDMA Mobile and FWP Phones		
Placement of Order for Machinery	April 2006	
Delivery of Machinery	March 2007	May 2007
Installation of Machinery	March 2007	May 2007
Trial Production	May 2007	
Commercial Production	June 2007	

(Source: Estimate by company's management)

Funds Deployed and Sources of Funds

The Company has deployed following funds as on 31st Oct 2006 on the proposed projects as certified by the Auditor.

The Company has incurred Rs. 1690.20 lakh for the Proposed project. Details of the amount incurred and sources for the same as certified by the Auditors M/s. Satyanarayana & Co., Chartered Accountants vide their certificate dated November 6, 2006 are as follows:

(Rs. In Lakh)

Sr. No.	Particulars	Amount
1.	Solar Expansion Plant (SPV Division)	278.00
2.	Repayment of Term Loan	100.00
3.	20% of dispatches made to BSNL till 31.10.06	1312.20
	Total	1690.20

The aforesaid amount was financed from Company's Internal Accrual.



The quarter-wise break-up of utilization of issue proceeds of the above mentioned capital expenditure program is stated below:

Rs. In Lakhs

Capital Expenditure Programme	Q2 (06-07) Oct-Dec	Q3 (06-07) Jan-March	Q4 (06-07) April-June	Total 2006-07
I. Solar Project				
1. Readiness of Equipment 20%	160			160
2. On Receipt of Machinery – 55%	118	322		440
3. On Installation – 15%		120		120
4. One Month after installation – 10%		80		80
Sub-Total	278	522		800
II. SMT Line Project				
1. Readiness of Equipment 20%	307			307
2. On Receipt of Machinery - 55%		1151		1151
3. On Installation – 15%			427	427
4. One Month after installation – 10%			155	155
Sub-Total	307	1151	582	2040
III. Repayment of Term Loans				
IDBI		900		900
IV. Working Capital				
FWP Order deferred payment portion investment	1690	310		2000
V. IPO Expenses	[●]	[●]	[●]	[●]
Total	[●]	[●]	[●]	[●]

(Source: Estimate by Company's management)

Interim use of proceeds

The management, in accordance with the policies set up by the Board, will have flexibility in deploying the proceeds received from the Issue after clearance from the Audit Committee. Pending utilization for the purposes described above, Company intends to temporarily invest the funds in fixed deposit, high quality interest/dividend bearing short term/long term liquid instruments. These investments shall be in accordance with investment policies approved by the Board of Directors from time to time.

Monitoring of utilization of funds

Company's Board and the Audit Committee will monitor the utilization of the proceeds of the Issue in addition to external agency of M/s. Canara Bank, who has consented to act as Monitoring Agency. Company will disclose the utilization of the proceeds of the Issue under a separate head in Company's balance sheets for fiscal 2007, and fiscal 2008 clearly specifying the purpose for which such proceeds have been utilized. The Company will also, in the balance sheets for fiscal 2007, and fiscal 2008 provide details, if any, in relation to all such proceeds of the Issue that have not been utilized thereby also indicating investments, if any, of such unutilized proceeds of the Issue.

NO PART OF THE PROCEEDS OF THE ISSUE WILL BE PAID BY US AS CONSIDERATION TO THE COMPANY'S PROMOTERS, DIRECTORS, KEY MANAGEMENT PERSONNEL OR COMPANIES PROMOTED BY THE PROMOTERS.



BASIC TERMS OF THE ISSUE

The Equity Shares being offered are subject to the provisions of the Companies Act, Company's Memorandum and Articles of Association, the terms of this Red Herring Prospectus, the Prospectus, the Bid cum Application Form, the Revision Form, the Confirmation of Allocation Note and other terms and conditions as may be incorporated in the allotment advices and other documents/ certificates that may be executed in respect of the Issue. The Equity Shares shall also be subject to laws as applicable, guidelines, notifications and regulations relating to the issue of capital and listing and trading of securities issued from time to time by SEBI, the Government of India, the Stock Exchanges, the RBI, ROC and/ or other authorities, as in force on the date of the Issue and to the extent applicable.

Ranking of Equity Shares

The Equity Shares being offered shall be subject to the provisions of Company's Memorandum and Articles of Association and shall rank *pari passu* in all respects with the existing Equity Shares including rights in respect of dividend. The Allottees will be entitled to dividend or any other corporate benefits (including dividend), if any, declared by the Company after the date of Allotment.

Mode of Payment of Dividend

The Company shall pay dividend to our shareholders as per the provisions of the Companies Act.

Face Value and Issue Price

The face value of the Equity Shares is Rs. 10 each and the Issue Price is Rs. [●] each. At any given point of time there shall be only one denomination for the Equity Shares.

Rights of the Equity Shareholders

Subject to applicable laws, the equity shareholders of our Company shall have the following rights:

- Right to receive dividend, if declared;
- Right to attend general meetings and exercise voting powers, unless prohibited by law;
- Right to vote on a poll either in person or by proxy;
- Right to receive offers for rights shares and be allotted bonus shares, if announced;
- Right to receive surplus on liquidation;
- Right of free transferability;
- Such other rights, as may be available to a shareholder of a listed public company under the Companies Act and the terms of the listing agreements with the Stock Exchanges; and
- Such other rights as may be available to our shareholders under our Memorandum and Articles of Association.

For a detailed description of the main provisions of our Articles of Association dealing with voting rights, dividend, forfeiture and lien, transfer and transmission and/ or consolidation/ splitting, pledge see the section titled "Main Provisions of Articles of Association" beginning on page 151.

Market Lot and Trading Lot

In terms of existing SEBI Guidelines, the trading in the Equity Shares shall only be in dematerialised form for all investors and hence, the tradable lot is one Equity Share. In terms of Section 68B of the Companies Act, the Equity Shares shall be allotted only in dematerialised form in multiples of one Equity Share subject to a minimum Allotment of 45 Equity Shares.

Nomination Facility to the Investor

In accordance with Section 109A of the Companies Act, the sole or First Bidder, along with other joint Bidder(s), may nominate any one person in whom, in the event of death of sole Bidder or in case of joint Bidders, death of all the Bidders, as the case may be, the Equity Shares Allotted, if any, shall vest. A person, being a nominee, entitled to the Equity Shares by reason of the death of the original holder(s), shall in accordance with Section 109A of the Companies Act, be entitled to the same advantages to which he or she would be entitled if he or she were the registered holder of the Equity Share(s). Where the nominee is a minor, the holder(s) may make a nomination to appoint, in the prescribed manner, any person to become entitled to Equity Share(s) in the event of his or her death during the minority. A nomination shall stand rescinded upon a sale/ transfer/ alienation of Equity Share(s) by the person nominating. A buyer will be entitled to make a fresh nomination in the manner prescribed. A fresh nomination can be made only on the prescribed form available on request at the registered office of the Company or at the registrar and transfer agent of the Company.



In accordance with Section 109B of the Companies Act, any person who becomes a nominee by virtue of the provisions of Section 109A of the Companies Act, shall upon the production of such evidence as may be required by the Company's Board, elect either:

1. to register himself or herself as the holder of the Equity Shares; or
2. to make such transfer of the Equity Shares, as the deceased holder could have made.

Further, our Board may at any time give notice requiring any nominee to choose either to be registered himself or herself or to transfer the Equity Shares, and if the notice is not complied with, within a period of 90 days, our Board may thereafter withhold payment of all dividends, bonuses or other monies payable in respect of the Equity Shares, until the requirements of the notice have been complied with.

Since the Allotment of Equity Shares in the Issue will be made only in dematerialised mode, there is no need to make a separate nomination with the Company. Nominations registered with the respective depository participant of the applicant would prevail. If the investors require changing the nomination, they are requested to inform their respective depository participant.

Minimum Subscription

If the Company does not receive the minimum subscription of 90% of the Fresh Issue to the extent of the amount including devolvement of the members of the Syndicate, if any, within 60 days from the Bid/ Issue Closing Date, the Company shall forthwith refund the entire subscription amount received. If there is a delay beyond eight days after the Company becomes liable to pay the amount, the Company shall pay interest as per Section 73 of the Companies Act.

Further, in accordance with Clause 2.2.2A of the SEBI Guidelines the Company shall ensure that the number of prospective Allottees to whom the Equity Shares will be allotted will be not less than 1,000.



BASIS FOR ISSUE PRICE

The Price Band for the Issue Price will be decided by us in consultation with the BRLMS and specified in the Red Herring Prospectus that will be filed with the Registrar of Companies.

Investors should read the following summary along with the sections titled “Risk Factors” and “Financial Information” beginning on pages xi and 85 of this Red Herring Prospectus respectively. The trading price of the Equity Shares of the Company could decline due to these risks and you may lose all or part of your investments.

Qualitative Factors

Telecom

- 1) India's only CDMA Handsets Manufacturer with Technology Partnership with International Players
- 2) Partnership agreement with Kyocera for assembly of Kyocera braded CDMA mobile handsets and sales in India – Agreement originally entered into 2001 and currently valid upto 2008
- 3) Partnership agreement with NASDAQ listed company AXESSTEL for Assembly and sale of FWP to Public Sector Undertakings. Agreement entered in 2005 and valid Upto 2008
- 4) Foray into retail market of CDMA handsets with tie-up with Reliance Infocom, TATA Indicom and MTNL for retail sales through their own network
- 5) Vendor relationship with all the major Indian CDMA Based Telecom Operators BSNL, MTNL TATA & Reliance Infocom.

Ethanol

- 1) India's one of the largest licensed and production capacity for Ethanol manufacturing with a capacity of 1,50,000 litres per day

Strong order Base

1. Firm Orders worth over Rs.22050 Lakhs for supply of 66,667 nos of 180 Wp Solar Photovoltaic Modules to Forta Imports and Exports S.L for next three years.
2. Pilot Order worth Rs.578.50 Lakhs for supply of Fixed Wireless Phones to Reliance Infocom, CDMA Private Operator in the Country.
3. XL has been invited for Price Negotiation by BSNL for issuing repeat order valued Rs.9600 Lakh for supply Fixed Wireless in view almost completion of present order of the same value and quantity. One firm order worth Rs. 9600 Lakh is already under execution.
4. XL has participated in the Maharashtra Tender for supply of Ethanol for next three years and has become the eligible 'L1 bidder'. This is after receipt of Rs. 10400 Lakh worth of firm orders from Oil companies (HPCL, BPCL & IOC)

Strong Management team and motivated workforce

- It is an established and profit making Company.
- The Company is focussed on Telecom and Energy business Sectors.
- Professionally managed by a team of qualified personnel.
- Proven track record with domestic as well as international customers.
- Customers include well-known corporate organizations, institutions, civic bodies and Public Sector Corporations.



Quantitative Factors

Information presented in this section is derived from our restated financial statements, prepared in accordance with Indian GAAP.

1. Weighted Earning Per Share (EPS) of Face Value of Rs. 10/-

	Net Profit after Tax (before extraordinary items) (Rs Lakh)	No. of Adjusted Equity Shares (Lakh)	EPS (Rs)	Weight
Year ended June 30, 2004	247.93	33.46	7.41	1
Year ended June 30, 2005	594.05	33.46	17.75	2
Year ended June 30, 2006	1081.04	105.42	10.25	3
Weighted Average			12.28	

Notes:

- 1) Earning Per Share (EPS) for the year ended on June 30, 2006 is Rs. 10.25
- 2) The earning per share has been computed on the basis of adjusted profits and losses for the respective years/ periods after considering the impact of accounting policy changes, prior period adjustments/ regroupings pertaining to earlier years and before extraordinary items (net of taxes including deferred tax) as per the Auditors' Report.
- 3) The weighted average EPS considered with face value of each Equity Share of Rs. 10 is Rs. 12.28.

2. Price/Earning (P/E) ratio in relation to the Issue Price of Rs. [●]

- a. Based on year ended June 30, 2006, EPS of Rs.10.25 is [●]
- b. Based on weighted average EPS of Rs. 12.28 is [●]
- c. Telecom Equipment Industry P/E^(a)

Highest	46.8	Shyam Telecom
Lowest	5.4	GoldstoneTele
Industry Composite	19	

^(a)Source: Capital Market Volume XXI/18 dated Nov 6 to Nov 19 2006

3. Return on Average Net Worth:

Year	Net Worth (Rs Lakh)	RONW %	Weight
Year ended June 30, 2004	2242.57	11.06%	1
Year ended June 30, 2005	2950.03	20.14%	2
Year ended June 30, 2006	7859.88	13.73%	3
Weighted Average		15.42%	

Note: The RoNW has been computed on the basis of adjusted profits and losses for the respective years/ periods after considering the impact of accounting policy changes, prior period adjustments/ regroupings pertaining to earlier years and before extraordinary items (net of taxes) as per the Auditors' Report.

4. Minimum Return on Increased Net Worth required to maintain an pre issue EPS of Rs. [●] is [●]%

5. Net Asset Value:

Net Asset Value per Equity Share represents shareholders' equity less miscellaneous expenses as divided by weighted average number of Equity Shares.

- (i) Net Asset Value per Equity Share as at June 30, 2006 is Rs.74.68
- (ii) Issue price Rs. [●]



(iii) The Net Asset Value per Equity Share after the Issue is Rs. [●]

6. Comparison with Industry / Peers Ratio

Since the Company's revenues are largely in CDMA Mobile Phones and Fixed Wireless Phones and competes with International Companies like NOKIA, Motorola, LG, Samsung etc., currently there are no competing Indian Companies for providing comparison of accounting ratios.

7. The face value of each Equity Share is Rs. 10 per Equity Share and the Issue Price of Rs. [●] per Equity Share is [●] times of the face value.

The face value of Equity Shares of our Company is Rs. 10/- and the Issue Price is [●] time of the face value. The Issue Price of Rs. [●] has been determined by our Company in consultation with the BRLMS, on the basis of assessment of market demand for the Equity Shares by way of Book Building and is justified on the basis of the above factors.

Investors are advised to refer to sections titled "Risk Factors" and "Financial Information" beginning on pages xi and 85 of this Red Herring Prospectus.



STATEMENT OF TAX BENEFITS

To,
The Board of Directors,
XL Telecom Limited
335, Chandralok Complex,
SD Road,
Secundrabad - 500 003.

Statement of possible tax benefits available to the Company and to its Shareholders

Benefits under the Income Tax Act, 1961

As per the existing provisions of the Income Tax Act, 1961 (the IT Act) and other laws as applicable for the time being in force, the following tax benefits and deductions are and will, inter-alia be available to M/s XL Telecom Limited and its shareholders.

A. TO THE COMPANY

1. Dividend income (whether interim or final), in the hands of the company as distributed or paid by any other Company on or after April 1, 2003 is completely exempt from tax in the hands of the Company, under section 10(34) of the IT Act.
2. Long-term capital gains would be subject to tax at the rate of 20% (plus applicable surcharge and education cess) as per the provisions of section 112(1) (b) of the IT Act. However, as per the proviso to Section 112(1) (b), the long term capital gains resulting on transfer of listed securities or units, (not covered by section 10(36) and 10(38)), would be subject to tax at the rate of @ 20% with indexation benefits or 10% without indexation benefits (plus applicable surcharge and education cess) as per the option of the assessee.
3. Long term capital gain arising from transfer of an 'eligible equity share' in a Company Purchased on or after the 1st day of March, 2003 and before the 1st day of March, 2004 (both days inclusive) and held for a period of 12 months or more is exempt from tax under section 10(36) of the IT Act.
4. Long term capital gain arising from the sale of Equity Shares in any company through a recognised stock exchange or from the sale of units of an equity oriented mutual fund shall be exempt from Income Tax if such sale takes place after 1st of October 2004 and such sale is subject to Securities Transaction tax, as per the provisions of section 10(38) of the IT Act.
5. Short Term capital gains arising from the transfer of Equity Shares in any company through a recognised stock exchange or from the sale of units of equity-oriented mutual fund shall be subject to tax @ 10% provided such a transaction is entered into after the 1st day of October, 2004 and the transaction is subject to Securities Transaction Tax, as per the provisions of section 111A of the IT Act.
6. In accordance with and subject to the conditions and to the extent specified in Section 54EC of the IT Act, the Company would be entitled to exemption from tax on gains arising from transfer of the long term capital asset (not covered by section 10(36) and section 10 (38)) if such capital gain is invested in any of the long-term specified assets in the manner prescribed in the said section. Where the long-term specified asset is transferred or converted into money at any time within a period of three years from the date of its acquisition, the amount of capital gains exempted earlier would become chargeable to tax as long term capital gains in the year in which the long-term specified asset is transferred or converted into money.
7. As per the provisions of Section 54ED of the IT Act and subject to the conditions specified therein, capital gains arising from transfer of long term assets, being listed securities or units (not covered by section 10(36) and section 10(38)) shall not be chargeable to tax to the extent such gains are invested in acquiring Equity Shares forming part of an 'eligible issue of share capital' in the manner prescribed in the said section.

B. TO RESIDENT SHAREHOLDERS

1. Dividend (whether interim or final) declared, distributed or paid by the Company on or after April 1, 2003 is completely exempt from tax in the hands of the shareholders of the Company as per the provisions of section 10(34) of the IT Act.
2. Any income of minor children clubbed with the total income of the parent under section 64(1A) of the IT Act, will be exempt from tax to the extent of Rs. 1500/- per minor child under section 10(32) of the IT Act.
3. as per the provisions of Section 112(1) (b) of the IT Act, long-term capital gains would be subject to tax at the rate of 20% (plus applicable surcharge and education cess). However, as per the proviso to Section 112(1) (b), the long term capital gains resulting on transfer of listed securities or units (not covered by sections 10(36) and 10(38)), would be subject to tax



at the rate of @ 20% with indexation benefits or 10% without indexation benefits (plus applicable surcharge and education cess) as per the option of the assessee.

4. Long term capital gain arising from the sale of Equity Shares in any company through a recognised stock exchange or from the sale of units of an equity oriented mutual fund shall be exempt from Income Tax if such sale takes place after 1st of October 2004 and the sale is subject to Securities Transaction tax, as per the provisions of section 10(38) of the IT Act.
5. Short Term capital gains arising from the transfer of Equity Shares in any company through a recognised stock exchange or from the sale of units of equity-oriented mutual fund shall be subject to tax @ 10% provided such a transaction is entered into after the 1st day of October, 2004 and the transaction is subject to Securities Transaction Tax, as per the provisions of section 111A of the IT Act.
6. As per the provisions of section 88E, where the business income of a resident includes profits and gains from sale of taxable securities, a rebate shall be allowed from the amount of income tax equal to the Securities transaction tax paid on such transactions. However the amount of rebate shall be limited to the amount arrived at by applying the average rate of income tax on such business income.
7. In accordance with and subject to the conditions and to the extent specified in Section 10(36) of the IT Act, the shareholders would be entitled to exemption from long term capital gain tax on transfer of their 'eligible Equity Share' in the Company purchased during the period March 1, 2003 to February 29, 2004 (both days inclusive) and held for a period of 12 months or more.
8. In accordance with and subject to the conditions and to the extent specified in Section 54EC of the IT Act, the shareholders would be entitled to exemption from tax on gains arising on transfer of their shares in the Company (not covered by sections 10(36) and 10(38)), if such capital gain is invested in any of the long term specified assets in the manner prescribed in the said section. Where the long-term specified asset is transferred or converted into money at any time within a period of three years from the date of its acquisition, the amount of capital gains exempted earlier would become chargeable to tax as long term capital gains in the year in which the long-term specified asset is transferred or converted into money.
9. In accordance with and subject to the conditions and to the extent specified the Section 54ED of the IT Act, the shareholders would be entitled to exemption from long term capital gain tax on transfer of their assets being listed securities or units (not covered by sections 10(36) and 10(38)), to the extent such capital gain is invested in acquiring Equity Shares forming part of an 'eligible issue of share capital' in the manner prescribed in the said section.
10. In case of a shareholder being an individual or a Hindu Undivided Family, in accordance with and subject to the conditions and to the extent specified in Section 54F of the IT Act, the shareholder would be entitled to exemption from long term capital gains on the sale of shares in the Company (not covered by sections 10 (36) and 10 (38)), upon investment of net consideration in purchase /construction of a residential house. If part of net consideration is invested within the prescribed period in a residential house, then such gains would not be chargeable to tax on a proportionate basis. Further, if the residential house in which the investment has been made is transferred within a period of three years from the date of its purchase or construction, the amount of capital gains shall be charged to tax as long-term capital gains in the year in which such residential house is transferred.

C. TO NON-RESIDENT INDIAN SHAREHOLDERS

1. Dividend (whether interim or final) declared, distributed or paid by the Company on or after April 1, 2003 is completely exempt from tax in the hands of the shareholders of the Company as per the provisions of section 10(34) of the IT Act.
2. Any income of minor children clubbed with the total income of the parent under Section 64(1A) of the IT Act will be exempt from tax to the extent of Rs. 1,500 per minor child per year in accordance with the provisions of section 10(32) of the IT Act.
3. In the case of shareholder being a non-resident Indian and subscribing to shares in convertible foreign exchange, in accordance with and subject to the conditions and to the extent specified in Section 115D read with Section 115E of the IT Act, long term capital gains arising from the transfer of an Indian company's shares (not covered by sections 10(36) and 10(38)), will be subject to tax at the rate of 10% as increased by a surcharge and education cess at an appropriate rate on the tax so computed, without any indexation benefit but with protection against foreign exchange fluctuation.
4. In case of a shareholder being a non-resident India, and subscribing to the share in convertible foreign exchange in accordance with and subject to the conditions and to the extent specified in Section 115F of the IT Act, the non-resident Indian shareholder would be entitled to exemption from long term capital gains (not covered by sections 10(36) and 10(38)) on the transfer of shares in the Company upon investment of net consideration in modes as specified in sub-section (1) of Section 115F.



5. In accordance with the provisions of Section 115G of the IT Act, Non Resident Indians are not obliged to file a return of income under Section 139(1) of the IT Act, if their only source of income is income from investments or long term capital gains earned on transfer of such investments or both, provided tax has been deducted at source from such income as per the provisions of Chapter XVII-B of the IT Act.
6. In accordance with the provisions of Section 115H of the IT Act, when a Non Resident Indian become assessable as a resident in India, he may furnish a declaration in writing to the Assessing Officer along with his return of income for that year under Section 139 of the IT Act to the effect that the provisions of Chapter XII-A shall continue to apply to him in relation to such investment income derived from the specified assets for that year and subsequent assessment years until such assets are converted into money.
7. As per the provisions of section 115 I of the /Act, a Non-Resident Indian may elect not to be governed by the provisions of Chapter XII-A for any assessment year by furnishing his return of income for that year under Section 139 of the IT Act, declaring therein that the provisions of Chapter XII-A shall not apply to him for that assessment year and accordingly his total income for that assessment year will be computed in accordance with the other provisions of the IT Act.
8. In accordance with and subject to the conditions and to the extent specified in Section 112(1) (b) of the IT Act, tax on long term capital gains arising on sale on listed securities or units not covered by sections 10(36) and 10(38) will be, at the option of the concerned shareholder, 10% of capital gains (computed without indexation benefits) or 20% of capital gains (computed with indexation benefits) as increased by a surcharge and Education cess at an appropriate rate on the tax so computed in either case.
9. As per the provisions of section 10(38), long term capital gain arising from the sale of Equity Shares in any company through a recognised stock exchange or from the sale of units of an equity oriented mutual fund shall be exempt from Income Tax if such sale takes place after 1st of October 2004 and such sale is subject to Securities Transaction tax.
10. As per the provisions of section 111 A, Short Term capital gains arising from the transfer of Equity Shares in any company through a recognised stock exchange or from the sale of units of equity-oriented mutual fund shall be subject to tax @ 10% provided such a transaction is entered into after the 1st day of October, 2004 and the transaction is subject to Securities Transaction Tax.
11. As per the provisions of section 88E, where the business income of an assessee includes profits and gains from sale of taxable securities, a rebate shall be allowed from the amount of income tax equal to the Securities transaction tax paid on such transactions. However the amount of rebate shall be limited to the amount arrived at by applying the average rate of income tax on such business income.
12. In accordance with and subject to the conditions and to the extent specified in Section 10(36) of the IT Act, the shareholders would be entitled to exemption from long term capital gain tax on transfer of their 'eligible Equity Shares' in the Company purchased during the period March 1, 2003 to February 29, 2004 (both days inclusive) and held for a period of 12 months or more.
13. In accordance with and subject to the conditions and to the extent specified in Section 54EC of the IT Act, the shareholders would be entitled to exemption from tax on long term capital gains (not covered by sections 10(36) and 10(38)) arising on transfer of their shares in the Company if such capital gain is invested in any of the long term specified assets in the manner prescribed in the said section. Where the long-term specified asset is transferred or converted into money at any time within a period of three years from the date of its acquisition, the amount of capital gains exempted earlier would become chargeable to tax as long term capital gains in the year in which the specified asset is transferred or converted into money.
14. In accordance with and subject to the conditions and to the extent specified in Section 54ED of the IT Act, the shareholder would be entitled to exemption from tax on long term capital gains (not covered by sections 10(36) and 10(38)) arising on transfer of their assets being listed securities or units to the extent such capital gain is invested in acquiring Equity Shares forming part of an 'eligible issue of share capital' in the manner prescribed in the said section.
15. In case of a shareholder being an individual or a Hindu Undivided Family, in accordance with and subject to the conditions and to the extent specified in Section 54F of the IT Act, the shareholder would be entitled to exemption from long term capital gains (not covered by sections 10(36) and 10(38)) on the sale of shares in the Company upon investment of net consideration in purchase / construction of a residential house. If part of net consideration is invested within the prescribed period in a residential house, then such gains would not be chargeable to tax on proportionate basis. Further, if the residential house in which the investment has been made is transferred within a period of three years from the date of its purchase or construction, the amount of capital gains tax exempted earlier would become chargeable to tax as long term capital gains in the year in which such residential house is transferred.



16. as per the provisions of Section 90(2) of the IT Act, the provisions of the IT Act would prevail over the provisions of the tax treaty to the extent they are more beneficial to the Non-Resident.

D. TO OTHER NON-RESIDENTS

1. Dividend (whether interim or final) declared, distributed or paid by the Company on or after April 1, 2003 is completely exempt from tax in the hands of the shareholders of the Company, under section 10(34) of the IT Act.
2. Any income of minor children clubbed with the total income of the parent under Section 64(1A) of the IT Act will be exempt from tax to the extent of Rs.1500 per minor child per year, in accordance with the provisions of section 10(32) of the IT Act.
3. In accordance with and subject to the conditions and to the extent specified in Section 112(1) (b) of the IT Act, tax on long term capital gains arising on sale on listed securities or units before 1st October 2004 will be, at the option of the concerned shareholder, 10% of capital gains (computed without indexation benefits) or 20% of capital gains (computed with indexation benefits) as increased by a surcharge and education cess at an appropriate rate on the tax so computed in either case.
4. As per the provisions of section 10(38), long term capital gain arising from the sale of Equity Shares in any company through a recognised stock exchange or from the sale of units of an equity oriented mutual fund shall be exempt from Income Tax if such sale takes place after 1st of October 2004 and such sale is subject to Securities Transaction tax.
5. As per the provisions of section 111 A, Short Term capital gains arising from the transfer of Equity Shares in any company through a recognised stock exchange or from the sale of units of equity-oriented mutual fund shall be subject to tax @ 10% provided such a transaction is entered into after the 1st day of October, 2004 and the transaction is subject to Securities Transaction Tax.
6. As per the provisions of section 88E, where the business income of an assessee includes profits and gains from sale of taxable securities, a rebate shall be allowed from the amount of income tax equal to the Securities transaction tax paid on such transactions. However the amount of rebate shall be limited to the amount arrived at by applying the average rate of income tax on such business income.
7. In accordance with and subject to the conditions and to the extent specified in Section 10(36) of the IT Act, the shareholders would be entitled to exemption from long term capital gain tax on transfer of their 'eligible Equity Share' in the Company purchased during the period March 1, 2003 to February 29, 2004 (both days inclusive) and held for a period of 12 months or more.
8. In accordance with and subject to the conditions and to the extent specified in Section 54EC of the IT Act, the shareholders would be entitled to exemption from tax on gains arising on transfer of their shares in the Company (not covered by sections 10(36) and 10(38)) if such capital gain is invested in any of the long term specified asset is transferred or converted into money at any time within a period of three years from the date of its acquisition, the amount of capital gains exempted earlier would become chargeable to tax as long term capital gains in the year in which the long-term specified asset is transferred or converted into money.
9. In accordance with and subject to the conditions and to the extent specified in Section 54ED of the IT Act, the shareholders would be entitled to exemption from long term capital gains (not covered by sections 10(36) and 10(38)) on transfer of their assets being listed securities or units to the extent such capital gain is invested in acquiring Equity Shares forming part of an 'eligible issue of share capital' in the manner prescribed in the said section.
10. In case of a shareholder being an individual or a Hindu Undivided Family, in accordance with and subject to the conditions and to the extent specified in Section 54F of the IT Act, the shareholder would be entitled to exemption from long term capital gains (not covered by sections 10(36) and 10(38)) on the sale of shares in the Company upon investment of net consideration in purchase/construction of a residential house. If part of net consideration is invested within the prescribed period in a residential house, then such gains would not be chargeable to tax on a proportionate basis. Further, if the residential house in which the investment has been made is transferred within a period of three years from the date of its purchase or construction, the amount of capital gains tax exempted earlier would become chargeable to tax as long term capital gains in the year in which such residential house is transferred.
11. as per the provisions of Section 90(2) of the IT Act, the provisions of the IT Act would prevail over the provisions of the tax treaty to the extent they are more beneficial to the Non Resident.

E. TO FOREIGN INSTITUTIONAL INVESTORS (FIIs)

1. In case of a shareholder being a Foreign Institutional Investor (FIIs), in accordance with and subject to the conditions and to the extent specified in Section 115AD of the IT Act, tax on long term capital gain (not covered by sections 10(36) and 10(38)) will be 10% and on short term capital gain will be 30% as increased by a surcharge and education cess at an appropriate rate on the tax so computed in either case. However short term capital gains on sale of Equity Shares of a



company through a recognised stock exchange or a unit of an equity oriented mutual fund effected on or after 1st October 2004 and subject to Securities transaction tax shall be taxed @ 10% as per the provisions of section 111A. It is to be noted that the benefits of Indexation and foreign currency fluctuation protection as provided by Section 48 of the IT Act are not available to FIIS.

2. As per the provision of Section 90(2) of the IT Act, the provisions of the IT Act would prevail over the provisions of the tax treaty to the extent they are more beneficial to the Non Resident.
3. In accordance with and subject to the conditions and to the extent specified in Section 10(36) of the IT Act, the shareholders would be entitled to exemption from long term capital gain tax on transfer of their 'eligible Equity Share' in the Company purchased during the period March 1, 2003 to February 29, 2004 (both days inclusive) and held for a period of 12 months or more.
4. Long term capital gain arising from the sale of Equity Shares in any company through a recognised stock exchange or from the sale of units of an equity oriented mutual fund shall be exempt from Income Tax if such sale takes place after 1st of October 2004 and such sale is subject to Securities Transaction tax, as per the provisions of section 10(38) of the IT Act.
5. As per the provisions of section 88E, where the business income of an assessee includes profits and gains from sale of taxable securities, a rebate shall be allowed from the amount of income tax equal to the Securities transaction tax paid on such transactions. However the amount of rebate shall be limited to the amount arrived at by applying the average rate of income tax on such business income.
6. In accordance with and subject to the conditions and to the extent specified in /section 54EC of the IT Act, the shareholders would be entitled to exemption from tax on long term capital gains (not covered by sections 10 (36) and 10(38)) arising on transfer of their shares in the Company if such capital gain is invested in any of the long term specified assets in the manner prescribed in the said section. Where the long term specified assets is transferred or converted into money at any time within a period of three years from the date of its acquisition, the amount of capital gains exempted earlier would become chargeable to tax as long term capital gains in the year in which the long term specified asset is transferred or converted into money.
7. In accordance with and subject to the conditions and to the extent specified in Section 54ED of the IT Act, the shareholders would be entitled to exemption from long term capital gain tax (not covered by sections 10 (36) and 10(38)) on transfer of their assets being listed securities or units to the extent such capital gain is invested in acquiring Equity Shares forming part of an 'eligible issue of share capital' in the manner prescribed in the said section.

F. TO MUTUAL FUNDS

In case of a shareholder being a Mutual fund, as per the provisions of Section 10 (23D) of the IT Act, any income of Mutual Funds registered under the Securities and Exchange Board of India Act, 1992 or Regulations made there under, Mutual Funds set up by public sector banks or public financial institutions and Mutual Funds authorised by the Reserve Bank of India would be exempt from Income Tax, subject to the conditions as the Central Government may by notification in the Official Gazette specify in this behalf.

G. TO VENTURE CAPITAL COMPANIES/ FUNDS

In case of a shareholder being a Venture Capital Company / Fund, as per the provisions of Section 10(23FB) of the IT Act, any income of Venture Capital Companies / Funds registered with the Securities and Exchange Board of India, would exempt from Income Tax, subject to the conditions specified.

Benefits under the Wealth Tax Act, 1957

As per the prevailing provisions of the above Act, no Wealth Tax shall be levied on value of shares of the Company.

Benefits under the Gift Tax Act

As no Gift tax is liveable in respect of gifts made on or after October 1, 1998, any gift of shares will not attract gift tax.

Notes:

1. All the above benefits are as per the current tax laws as amended by the Finance Act, 2005 and will be available only to the sole / first named holder in case the shares are held by joint holders.
2. In respect of non-residents, the tax rates and the consequent taxation mentioned above shall be further subject to any benefits available under the double taxation avoidance agreements, if any, between India and the country in which the non-resident has fiscal domicile.



3. In view of the individual nature of tax consequences, each investor is advised to consult his / her own tax advisor with respect to specific tax consequences of his / her participation in the scheme. The tax implications of an investment in the Equity Shares, particularly in view of the fact that certain recently enacted legislations may not have direct legal precedent or may have a different interpretation on the benefits which an investor can avail.

For **Satyanarayana & Co.**

Chartered Accountants

Partner

Membership No. 6239

Place: Hyderabad

Date: 05.11.2006



SECTION IV: ABOUT THE COMPANY

INDUSTRY OVERVIEW

Indian Telecom Industry

India has large pool of qualified and experienced professionals in various disciplines, particularly in information technology, telecommunication technology. English is widely spoken among professionals and in the business community as well as in many Government Offices across India. Successive Governments, since 1991, have laid emphasis on economic reforms resulting in lesser controls and liberalization of economic policies.

In pre-reform period till 1994, Indian Telecommunication Industry was largely driven by Public Sector Model – Monopoly regime, resulting in higher costs to customers and low Tele-density. This can be clearly seen from the marginal growth in the Tele-density of 0.02 in 1948, the first year of Indian Independence to 1.94 in 1998, a meager growth of 1.92 in 50 years.

Government of India's Telecom liberalization program initially started in the year 1994 with National Telecom Policy and then followed by setting up of Regulatory Authority (Telecom Regulatory Authority of India or TRAI) in 1997. The first Tariff order was passed in 1998, thus effecting realistically reform process in Indian Telecom Industry. National Telecom Policy 1999 pushed further this reform process, resulting phenomenal growth in Tele-density, called Phase II and the growth was largely driven by competitive Mobile Segment.

Post Reforms, the Tele-density jumped from 1.94 in 1998 to 5.11 in 2003 and further due to certain key decisions by GOI and TRAI, mobile segment has created growth to Tele-density from 5.11 in 2003 to 15.44 in Sep 2006. As one can see, the country witnessed only 1.92 Tele-density in the first 50 years where as in each of 2003-04 and 2004-05 the Tele-density has added about 2. Further due to creation of competitive environment and opening of the sector the prices have fallen significantly benefiting the large Indian consumers.

The Cellular and fixed line penetration levels in India are still lower than those in most developed countries in the world, offering significant potential for growth in the telecommunication Industry. In recent years, the Indian Telecommunication Industry has experienced high growth, though second only to China.

The total number of Cellular subscribers has reached about 129.51 million significantly surpassing the landline subscribers of 40.75 million in Sep 2006, clearly indicating the growth drivers. The Total Telecom Subscribers stands at 170.26 million with 15.44 Tele-density as at the end of Sep 2006.

Source: TRAI Press Releases published in their website www.trai.gov.in

As on March 31, in Millions

	2000	2001	2002	2003	2004	2005	2/2006	2008
	Actual	Actual	Actual	Actual	Actual	Actual	Actual	TRAI Projections
No of Land Lines	26.65	32.71	38.73	41.48	42.84	46.19	49.45	70.00
Growth		22.74%	18.40%	7.10%	3.28%	7.82%	7.06%	41.55%
No of Mobiles	1.88	3.58	6.54	13.00	33.70	53.37	84.88	180.00
Growth		90.43%	82.68%	98.78%	159.23%	58.37%	59.04%	112.06%
Total Lines	28.53	36.29	45.27	54.48	76.54	99.56	134.33	250.00
Growth		27.20%	24.75%	20.34%	40.49%	30.08%	34.92%	86.11%
Tele-density	2.86	3.58	4.28	5.11	7.02	9.11	12.28	22.50
Growth		25.17%	19.55%	19.39%	37.38%	29.77%	34.79%	83.22%
Mobile Growth								
GSM Connections	1.88	3.58	6.54	12.69	26.15	41.04	63.34	100.00
Growth		90.43%	82.68%	94.04%	106.07%	56.94%	54.33%	57.88%
CDMA Connections				0.31	7.54	12.33	21.54	80.00
Growth					2332.26%	63.53%	74.70%	271.40%

Source: TRAI Website – A Study Paper Published by TRAI in consultation with Operators.



Indian Telecom Regulatory Authority conducted a survey and came out with Targets/ Projections for the next 3 years based on the demand in India considering both in Urban and Rural segments in addition to thrust being given by the Telecom Minister and his Growth Plans for the country. According to TRAI:

1. The Tele-density should reach to 22.50 from the current 15.44 as of End Sep 06 – EACH YEAR MUST GROW GREATER THAN 4.5 to 5.
2. This means in absolute terms – 250 million connections by 2008 – a whopping 46% growth over current 170.26 million (as of end Sep' 06) connections in One and half year period.
3. Fixed Line Connections are expected to increase from the existing 40.75 million as of 30.09.2006 to 70 Million by 2008 – MARGINAL GROWTH IN LINE WITH OTHER COUNTRIES

Mobile segment (GSM & CDMA combined) should witness growth from the existing 129.51 millions as of 30.09.2006 to 180 million by 2008 – Considering the current monthly additions of over 5 million for last 3 months since July 2006 the Target of 180 million could possibly be achieved with ease and in all probability would be exceeded.

Current Directions in the Mobile Market

The mobile industry is estimated to be around Rs 23,284 crore (USD 5.2 billion) in 2004-05, an increase of 63 per cent. The year earlier, the industry, as per Voice and Data estimates, was around Rs 14,267 crore (USD 3.2 billion).

Annual growth of mobile subscribers is still high: about 43.68% in the current year (First 6 months 39.37 million subscribers).. At the end of Sep 2006, the mobile subscriber base was close to 129.51 million reaching the target almost. Currently about 5 million subscribers are being added monthly. "At current rates, India can easily reach the targets set by the Hon'ble Minister of 180 Million mobile connections by 2008.

In 2006-07, during the first 6 months ending Sep 2006 the mobile segment has seen tremendous growth of over 43.68%. The number of mobile subscribers for the first 6 months in the current fiscal is of the order of 39.67 million.

Growth of mobile subscriber base

(Millions)

March-ended	GSM	CDMA	Total
2003	12.69	0.31	13.00
2004	26.15	7.54	33.69
2005	41.04	12.33*	53.37
Dec 2005	58.50	19.13	77.63
June 2006	78.49	26.87	105.36

*Adjusting for Reliance de-provisioning of 984,123 terminals of defaulting subscribers

Source: COAI, AUSPI

Monthly growth of subscribers

(Monthly average in millions)

	April	May	June	July	Aug	Sep	Oct	Nov	Dec	Jan, 06	Feb, 06	Total
2003-04	0.64	2.26	1.42	2.31	1.79	1.61	1.67	1.90	1.69	1.58	1.60	18.47
2004-05	1.37	1.33	1.42	1.74	1.67	1.84	1.51	1.56	1.95	1.76	1.67	17.84
2005-06	1.46	1.72	1.98	2.45	2.74	2.48	2.90	3.51	4.46	4.69	4.27	32.66
Growth	6.57%	29.32%	39.44%	40.80%	64.07%	34.78%	92.05%	125%	128.7%	166.5%	155.7%	83.07%

Source: COAI, AUSPI and TRAI websites

CDMA MARKET SHARE

The operator-wise position in CDMA is given in following Tables. Reliance dominates CDMA-mobile, with 75% of the subscribers, followed by BSNL (12.6%) and Tata Teleservices (10%). In the fixed wireless segment, Tata Teleservices leads, with a market share of 50%, followed by Reliance (25%) and BSNL. Both Reliance and Tata operate CDMA services in 20 circles.



Growth of CDMA-Mobile subscribers - Operator-wise

(Millions)

	Dec '04	Mar '05	Jun '05	Sep '05	Dec '05	Jan'06	Feb '06
BSNL	1.47	1.63	1.69	1.94	2.22	2.30*	2.40*
MTNL	0.18	0.20	0.18	0.15	0.13	0.12	0.12*
Reliance	9.12	9.33	10.29	11.41	13.01	13.82	14.62
Tata	0.81	1.09	1.43	2.06	3.68	4.06	4.37
HFCL	0.05	0.05	0.05	0.06	0.06	0.07	0.06
Shyam	0.03	0.03	0.03	0.03	0.03	0.03	0.03
Total	11.66	12.33	13.68	15.65	19.13	20.40	21.60

*estimate

Source: based on AUSPI data

The mobile handset business

While Mobile Industry is booming, it's no surprise that the mobile handset industry is booming too. According to the magazine Voice and data, in terms of volume, India witnessed a total sale of around 46 million handsets (including replacement demand) in 2005-06 of which 39.57 million were in the legal market and compare this to 26 million phones in the previous year a leap of 20 million phones in absolute number and about 80% growth. Out of the legal demand GSM contributed around 27.4 million, whereas CDMA contributed around 12.17 million. The magazine says that falling CDMA handset prices had an impact on the overall handset market in 2004-05 and 2005-06. In value terms, India's mobile handset market that year came to around \$4.5 billion against \$2.68 billion the year earlier: the market grew by around 68%. GSM contributed around 68.8% of this market and CDMA contributed about 31.2% and \$1.4 billion in absolute terms.

Handset demand in 2005-06

(Million)

	New demand	Replacement demand*	Total demand	Legal handset demand
GSM	27.66	6.57	34.23	27.44
CDMA	10.42	1.75	12.17	12.17
Total	38.10	9.95	46.40	39.57

*Estimate. For GSM, replacement demand is taken at 16% of the **previous year's** user base in 2005-06.

Handset demand growth over 2004-06

(Million)

Fiscal Year	New Demand	Replacement Demand*	Total demand	Legal handset demand
GSM demand				
2004-05	14.89	4.18	19.07	15.3
2005-06	27.66	6.57	34.23	27.4
CDMA demand				
2004-05	6.00	0.75	6.75	6.75
2005-06	10.42	1.75	12.17	12.17
Total demand				
2004-05	20.89	4.93	25.82	21.53
2005-06	38.10	9.95	46.40	39.57
Growth	82.38%	101.82%	79.70%	83.79%

*Estimate. For GSM, replacement demand is taken at 14% of the **previous year's** user base in 2003-04 and 16% in 2004-05.



Handsets business was estimated at \$4.55 billion in 2005-06 compared to an estimated \$2.81 billion market in 2004-05. For the calendar year 2004 ICA advance estimates were for sales to reach \$3.3 billion, but this assumed a higher rate of CDMA growth which did not materialize.

Handset market estimates

Year ended March	Market for GSM handsets (Rs. Million / \$billion)	Market for CDMA handsets (Rs. Million / \$billion)	Total market (Rs. million)	Total market (\$ billion)
2002-2003	Rs. 25780	Rs. 1860	27640	
2003-2004	Rs. 59440 (\$1.26 billion)	Rs. 43380 (\$0.96 billion)	102820	2.27
Calendar year 2004 ICA projection made in early 2004	\$1.8 billion	\$1.5 billion	-	3.3
2004-05 (est.)	Rs. 92130 (\$2.06 billion)	Rs. 33780 (\$0.75 billion)	125910	2.81
2005-06 (est.)	Rs. 140375 (\$3.17 billion)	Rs. 60850 (\$1.38 billion)	201225	4.55

Assumptions: Legal GSM handset Rs. 5000, grey market GSM handset Rs.3000, CDMA handset Rs6000. Exchange rate \$1:Rs47 in 2002-03 and \$1:Rs.45.3 in 2003-04 and Rs.44.8 in 2004-05

ICA: Indian Cellular Association

Source: Independent Research report from Tele.net



BUSINESS OVERVIEW

XL Telecom's business is divided into three Strategic Business Units.

- i. Telecom – Mobile Handsets, SMPS etc.
- ii. Solar Photovoltaic Systems
- iii. Ethanol

TELECOM DIVISION

CDMA Mobile Handset Manufacturing:

XL has partnered with International Brand KYOCERA for establishing a assembly unit for CDMA Mobile Handsets. XL has currently installed capacity of over 3 Million Handsets per annum. XL is the only independent assembler/manufacturer of CDMA Handsets, while other Competitors like LG and Samsung have established their own units in India. (Company estimates)

Industry Leaders like BSNL and MTNL have made it compulsory for the vendors to establish the manufacturing facility to be eligible to participate in their tenders. Further, with the establishment of the manufacturing facility, XL could compete in the extremely tough price sensitive market like India, especially leveraging the duty differentials.

The Company has supplied to all CDMA Operators like BSNL, MTNL, TATA and Reliance over 1 Million Mobile Phones and about 15 Models.

The Company is in a position to keep pace with the growing market/technology requirements and is equipped to participate in VoIP and 3G Technology at an appropriate time.

Market:

At the end of June 2006, there were estimated 112.15 Million Cellular subscriptions, out of which CDMA connections accounted for about 26.87 Million, which is about 24%. New Additions in the CDMA Mobile Segment alone is of the order of 5.92 million in the April to June 2006 Quarter, accounting for about 26.90% of total additions.

Mobile Phone Segment in India is rapidly growing and is second only to China. The Industry has grown almost 10 times from March 2003 to September 2006, from 13 million in March 2003 to about 129.51 million in September 2006. The Industry is expected to continue to see these (70 to 80% per annum) growth rates in the coming years. During the current fiscal year the Industry has grown about 43.67% in the first 6 months ending Sep 2006. As per TRAI and other various research organizations, the Mobile segment is expected to touch to 180 million by 2008, effectively another 39% growth in the next 1.5 years time frame, CDMA handset Market in the country will touch \$3.5 Billion in 2007 as compared to an estimated \$1.6 Billion at the end of 2004, as per Indian Cellular Association.

Source: Auspi and TRAI

With the announcement of TATA and BSNL to expand the services for another few thousands of towns, especially in the rural segment Company sees opportunity and growth for the company in the areas of CDMA Handsets and Fixed Wireless Phones.

Handset demand: 2004-2008 (volumes)

(Millions)

	GSM	% annual growth	CDMA	% annual growth	Total
2003	11.80		6		17.8
2004	18.52	56.9%	5	(-)17%	23.52
2005	31.00	67.56%	11	120%	42
2008	81.87	30%	41	30%	156

Source: Research Report from Tele.net

XL Estimates for their CDMA Sales:

Considering the opportunity in the Mobile Segment and more particularly, the CDMA Mobile segment, XL is positioning itself to have significant Market share both in the low end high growth Mobile handset segment sold through volume sales to Telecom Carriers and Higher-end Mobile Phones through Open Market Operations for higher price and margin realization for the next 3 to 5 years. XL decision to create the Distribution Network across the country in the 3rd Quarter of 2005 should help the company to reach the potential customer base without any problems.



SMPS Power Systems:

XL has established a facility to manufacture SMPS Power Systems in co-ordination with SMPS De Austria in the year 2000 with a capital outlay of about Rs.950 Lakhs, largely funded by IDBI and the balance from internal accruals. XL has full range of Power Systems needed by several Telecom Operators like BSNL, MTNL, Reliance, Bharti etc., SMPS Power Systems manufactured by XL has enabled the Company to enter into international Network Integrators like Nortel, Ericsson etc., XL supplies complete range to help the carriers to meet their demands.

Market:

As per Company's estimates, SMPS Power Systems market is estimated at about Rs.12500 Lakhs per annum. XL has been enjoying the market share between 10 to 20% for the past 5 years. With the ever increasing Telecom penetration and the projected 250 Million connections target by 2008, there is growth opportunity for the product both in Telecom Exchanges of conventional wired line requirement and BTS Stations in the Mobile segment. XL is confident of retaining its current market share in the coming years.

Outside Plant Accessories:

(Jointing Kits, Optic Fiber Accessories, and Fusion Splicers etc)

XL has been supplier of these outside plant accessories for over 2 decades with a Market share of about 40% in Jointing Kit business. However, with the evolution of Mobile segment and growth in the Tele-density in the last 7 years only due to Mobile penetration, the demand for the company's Jointing Kits has come down drastically. However, with the new thrust for the land line growth by the Telecom Minister from existing 46 Million lines to 70 million lines by 2008, the Company is expected to have reasonable level of revenues, though miniscule compared to over all revenues.

NON-TELECOM PRODUCTS:

Solar Photo Voltaic Systems:

XL has established a Solar Photo Voltaic Module Manufacturing facility in the year 1995. XL has initially entered into this segment to largely cater to BSNL's Village Public Telephone requirements valued about Rs.25000 Lakhs.

XL has received orders in the first year of establishment, valued over Rs.3000 Lakhs and executing with in the time frame stipulated by BSNL and meeting all the quality standards and going through approval procedures etc.,

However, due to various political reasons, BSNL has decided in the subsequent years to drop the procurement of SPV Systems, which in turn helped the Company to focus in other Non-conventional Energy Segments. XL product range includes, Solar Photovoltaic Power Plants – stand alone and Grid Based, SPV Home and Street Lighting Systems, Solar Lanterns etc.,

XL is supplier of these SPV Systems to various Non-Conventional Energy agencies for the past decade and have also export its Modules to various countries.

Currently looking at the demand in Germany and other parts of Europe for the SPV Systems, XL has entered into 'exclusive distribution agreement' with Forta Im Ex SL, an Spanish Company with a minimum commitment of 3 MW per annum. The agreement is valid for a period of 3 years and hence the total minimum uplift committed by the European customer is of the order of 12 MW which at current prices works Rs.22000 Lakhs.

ETHANOL:

Ethanol is used as an automotive fuel by itself and can be mixed with gasoline to form what has been called 'gasohol'. FUEL ETHANOL – the most common blends contains 10% of Ethanol. Because of the ethanol molecule contains oxygen, it allows the engine to more completely combust the fuel, resulting in fewer emissions. Since ethanol is produced from plants that harness the power of sun, ethanol is also considered a renewable fuel.

XL has established manufacturing facility at Nanded, Maharashtra after obtaining the necessary license. XL is one of largest licensed and production capacity currently in India with 1,50,000 litres capacity per day. XL facilities have been inspected and cleared technically by Oil companies both in terms of capacity evaluation and the quality of the product being produced. XL has started the supplies in the year 2006 and has achieved revenues of Rs.5938.14 Lakh in the year 2005-06.

Market:

Demand for fuel Ethanol depends on the projected growth in petrol demand in the country. As per IDBI study (July 2002), the demand for petroleum products is estimated to grow at a CAGR of 4.5% and reach 122 million tones by FY 2007. Accordingly the demand for petrol is estimated at 9.85 million tonnes or 13.3 billion litres and demand for anhydrous ethanol works out to around 668 million litres by FY 2007, based on the current policy decision of 5% Mix allowed by GOI.



Demand for Fuel Ethanol

	2005	2006	2007
Demand for Petrol			
Million Tonnes	8.60	9.20	9.85
Billion Litres	11.66	12.48	13.35
Demand for Ethanol			
Million Litres @5%	583.13	623.88	667.62
Million Litres @10% Blend	1166.26	1247.76	1335.24
Market Value @Rs.20 Per Ltr	Rs.2300 Crs	Rs.2500 Crs	Rs.2700 Crs

Source: IDBI Study Paper (July 2002) as amended with latest pricing by Management

The details of Company's Registered Office and factory are provided below:

S.No	Location	Utilisation
1	335, Chandralok Complex, SD Road, Secunderabad - 500 003	Registered Office
2	Shed No 30,31,32 –IDA, Mallapur-Hyderabad – 500 076	Factory for Joining Kits, Optic Fiber Accessories & SPV Equipments
3	Plot No 198/A & B, IDA, Cherlapally – Hyderabad –500051	Factory for HS Profile Manufacturing, CDMA Mobiles, SMPS Power Systems
4	Plot Nos B8 to B10 & B18 to B21, MIDC Kushnoor, Nanded, Maharashtra	Ethanol Plant

Collaborations

Company does not have any collaboration, any performance guarantee or assistance in marketing by the collaborators.

INFRASTRUCTURE FACILITIES

Raw materials

CDMA Handsets being assembled in India by XL, by importing all the components of Handsets from Technology Partner, Kyocera. Similarly for FWP Phones the Company imports the components from Axesstel.

For Ethanol division, Molasses is the major raw material, which has been procured in the domestic market.

For SMPS Power Systems Company procures raw materials substantially from the domestic Market. Similarly for Jointing Kits, Major components are procured domestically only. Both these products has very little import component.

UTILITIES

1. CHERLAPALLY PLANT:

POWER: Total power requirement for the Unit is estimated at 236 KVA. Unit has required connection from APSEB with sufficient back up of DG with 160 KVA in case of break down or tripping or power cuts.

WATER: Unit has sufficient water from the Municipality and own bore-well as a back up.

POLLUTION: Unit has pollution control board clearance for all its products. Unit produces only electronic items and mainly assembly and hence does not cause any environment issues.

MANPOWER: Unit employs about 150 employees of both technical and non technical grades. Unit also employs about 100 contract employees as and when necessary. Unit having located in the Electronic Industrial Area has no problems in sourcing the right technical talent.



2. ETHANOL PLANT AT NANDED:

POWER: Total power requirement for the Unit is estimated at 1680 Kwh per day. Unit has required Power connection of 500 KVA from MSEB with sufficient back up of DG with 360 KVA in case of break down or tripping or power cuts.

WATER: Unit has sufficient water from the Municipality and own bore-well as a back up. Unit needs about 185 M3 per day.

POLLUTION: Unit has pollution control board clearance for Ethanol Production; the process involved is only de-hydration it does not produce any pollution.

MANPOWER: Unit employs about 100 employees of both technical and non technical grades. Unit also employs about 50 contract employees as and when necessary. Unit having located in the Industrial Area has no problems in sourcing the right technical talent.

3. MALLAPUR PLANT:

POWER: Total power requirement for the Unit is estimated at 250 KVA. Unit has required Power Connection from APSEB with sufficient back up of DG with 500 KVA in case of break down or tripping or power cuts.

WATER: Unit has sufficient water from the Municipality and own bore-well as a back up. Production process does not need water.

POLLUTION: Unit has pollution control board clearance for all products being produced in the Unit. Products being manufactured or assemble in the factory does not produce any pollution.

MANPOWER: Unit employs about 25 employees of both technical and non technical grades. Unit also employs about 50 contract employees as and when necessary. Unit having located in the Industrial Area has no problems in sourcing the right technical talent.

PRODUCTS & SERVICES

The Company is into business of manufacturing of CDMA mobile handsets. The products that it manufactures are as follows:

Telecom Products:

- a) CDMA Mobile Handset Manufacturing
- b) SMPS Power Systems
- c) Outside Plant Accessories (Joining Kits, Optic Fiber Accessories, Fusion Splicers etc.)

Non-Telecom Products:

- a) Solar Photo Voltaic Systems
- b) Ethanol

CDMA

XL is the first Indian Company to establish a manufacturing facility for CDMA Mobile handsets in India, as an Independent Company, in Technical partnership with internationally market player Kyocera. XL has a capacity of about 10,000 Mobile Handsets per day and 35 Lakh handsets per annum. XL has supplied multiple models and till date has sold over 10 lakh handsets to all the market players like TATA, MTNL and BSNL. XL is in process of establishing the distribution network to reach the vast Indian customer base.

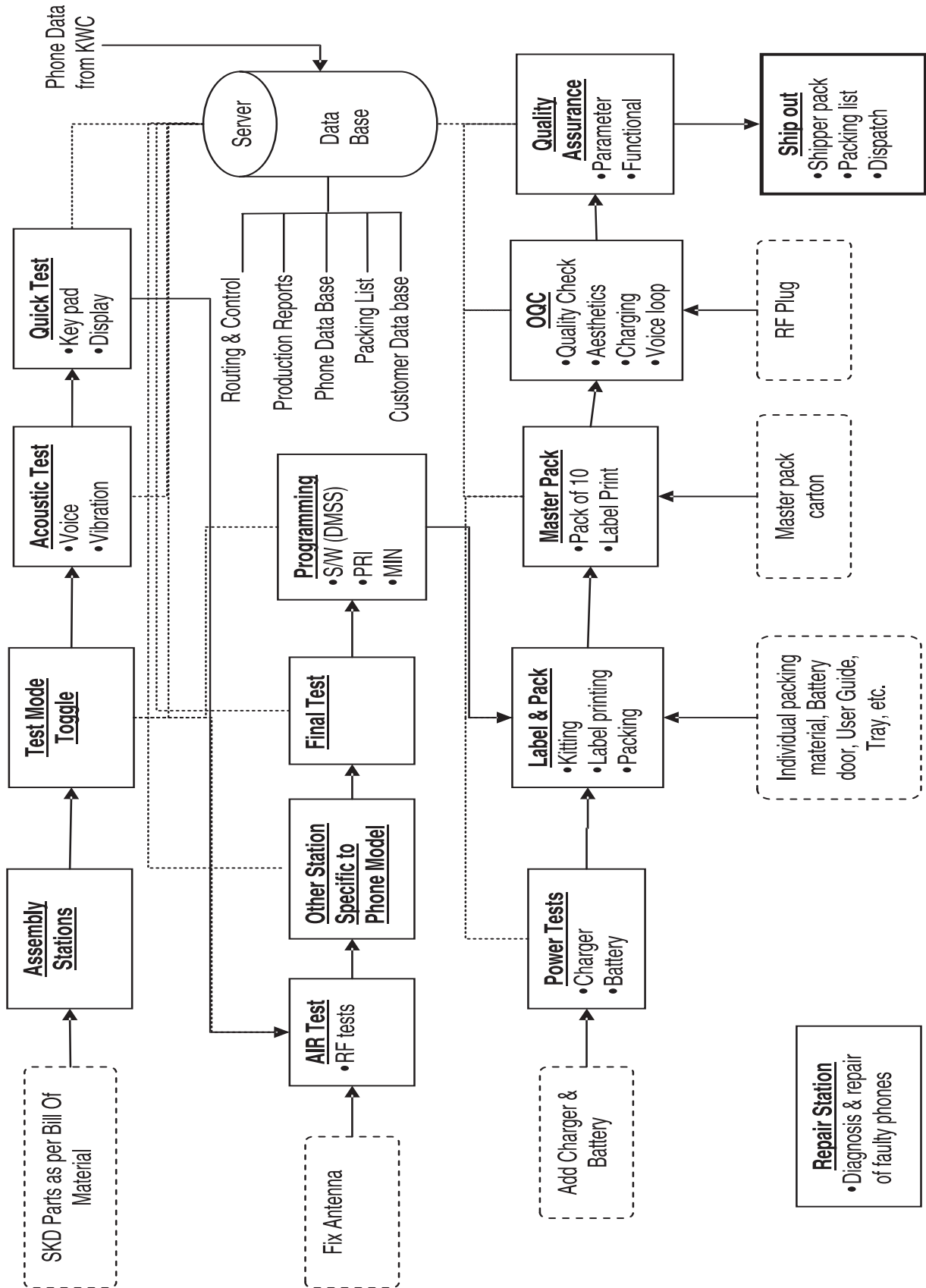



The Procedure for Assembly of each model changes slightly depending upon the design.

Instructions for Operators

ESD Warning: Components on CCA are very sensitive to ESD. Operators must wear ESD Aprons and ESD straps before handling CCA's. Operators should not handle more than ONE CCA at a time.

Torque Driver: At the beginning of the shift check whether Torque Driver is calibrated and values are noted in Torque Monitor Log Sheet, if not call the In-charge for Calibration.

Note: Operator has freedom to setup assembly station to accommodate his/her needs.

1. Place rear housing into rear nest and engage contact to antenna nut.
2. Inspect Rear Housings for presence of Antenna Nut, Antenna Tube and SAR bracket.
Note: Hole in SAR bracket must align with hole in housing, if not aligned, reject Rear Housing.
3. Place CCA into Rear Housing.
Note: Do not remove B2B Connector Cover before placing CCA into housing.
4. Remove B2B connector cover (If Present) from CCA by pressing on one side, then rotating cover off. Discard cover.
5. Inspect CCA for damage to Board-to-Board Connector and SAR gasket.
6. Place Shield Frame into Rear Housing.
7. Ensure that Shield Frame is properly installed and flat on CCA.
8. Install screws to rear housing (sequence – Center, Left, Right) Use finger to apply light pressure to Shield while installing Screws.
9. Verify that green LED is lit after third screwed has been installed. Light pressure may be applied to Shield Frame to engage contacts.
Note: If LEDs do not light, remove screws and repeat step 8. If LED still does not light, reject Rear Assembly to Triage operator for repair.
10. Inspect Board-to-Board connector for bent/damaged pins. If bent pins are found, remove screws and reject CCA to Triage operator for repair.
11. Inspect front housing for SAR pillow. SAR pillow must be within molded ribs in housing. Reject Front Housing if SAR pillow is not present, or outside of molded ribs.
12. Blow off Lens in Front Housing to remove debris and contamination. Inspect front of housing for scratches or defects per Inspection criteria defined in (Cosmetic Workmanship Standard) and reject if found.
13. Inspect Lens for contamination and debris. If contamination or debris cannot be removed with air pressure, reject Front Housing.
14. Place Front Housing into assembly fixture (white front).
Note: Bottom of housing will engage under tab in fixture. This will hold housing when rear housing is installed.
15. Place Speaker into Front Housing.
Caution: Do not touch Speaker contacts; the Oils in your fingers may damage contacts.
16. Install Keypad to Front Housing
Note: Place keypad into top of housing first and then lay keypad into housing.
17. Place leg of Keyboard under snap.
Note: Orient leg of Keyboard under snap.
18. Orient bottom of Keyboard into housing and snap into place.
Note: Move Keyboard against stop in housing.
19. Orient Keyboard on pin in housing.



20. Place vibrator into front housing against wall.
 21. Press vibrator into well.
Caution: Do not touch Vibrator contacts; the Oils in your fingers may damage contacts.
 22. Place microphone into housing.
Note: Contacts must be facing up, but orientation does not matter. Tweezers or hands may be used to place Microphone.

Caution: Do not touch Microphone contacts; the Oils in your fingers may damage contacts. And Do not insert microphone at an angle inside well.
 23. Remove Rear Housing from nest and place on to front housing.
Note: Hooks on Rear Housing will engage with tabs in Front Housing.
 24. Ensure that rear housing is fully seated into Front Housing by moving rear housing to top against.
 25. Top of housing should be aligned.
 26. Press Rear Housing onto Front Housing
Note: Press on locations above snaps to snap rear housing onto front housing.
 27. Install Screws to Rear housing. Use fingers to apply light pressure while installing screws.
 28. Inspect Keypad to ensure no keys are stuck under housing. If keys are found stuck under housing, press key to free it from housing. Inspect front housing for scratches or defects per inspection criteria defined in (Cosmetic Workmanship Standard) and reject if found.
 29. Inspect gaps on side of phone to ensure phone is snapped together correctly. Press phone together with hand if not completely snapped the re-torque.
 30. Inspect bottom of phone to ensure that housings are snapped, press the phone together with your hands the re-torque.
- Once phone has been inspected, and is found to be acceptable, write assigned assembly number on CCA in back of phone

SMPS power Systems

In 2000, the Company has diversified into Power Electronics, by establishing the world class manufacturing facility to produce Switch Mode Power Systems (SMPS). SMPS are generally used by DoT, MTNL and other Private Operations like Bharti, Reliance, IDEA, and Hutch, TATA etc. in their exchanges as well as BTS stations in the Mobile Segment. XL has entered into technical partnership agreement with Austrian Company.

The Manufacturing of SMPS is carried out in the following stages:

- Module Assembly
- Rack Assembly
- System Testing

Assembly Process Instructions:

SMPS MODULE ASSEMBLY

1. The Module Mechanical Assembly (MMA) will be carried as per the Assembly Process Instructions XL/SMPS/AI.
2. Ensuring that structural parts of the MMA are mounted properly and screws shall be firmly tightened with all appropriate hardware like plain/spring washers.

SMPS RACK ASSEMBLY

1. The racks accepted by the QA shall be taken for rack assembly.

Assembly of Rack shall be divided into two categories.

- Mechanical Assembly
- Electrical wiring

Mechanical assembly and electrical wiring is done as per the Assembly Process instructions and the engineering instructions.



IDENTIFICATION AND LABELLING

1. Power plant nameplate shall be fixed on the front side of the rack. It contains type approval, Sl. No., power plant capacity and date of Manufacturing
2. System Rating and application of the Rack shall be screen printed on front side of the Rack
3. Appropriate wiring diagram, necessary instructions shall be screen printed inside the rear door of the system.
4. Earth symbol shall be screen printed to the bottom side of the rack.

SYSTEM TESTING

1. PCB testing is done by the PCB testing Department as per the PCB Test Instructions XL/SMPS/PCB – TI
2. Module and Rack testing is done by the individual departments respectively as per the Product Test Instructions XL/SMPS/PTI
3. Tested modules & main controller unit shall be placed inside the rack as per the requirement.
4. Internally tested rack shall be tested in Burn in test for 72 hours during customer inspection.
5. Module performance, load sharing test will be done internally and after Burn in test. Same tests will be conducted during customer inspection

PRINCIPLE OPERATION OF SMPS

The typical SMPS module consists of an AC to DC Converter, DC to AC high frequency switching unit, step down isolation transformer, AC to DC high frequency rectifier and filter unit. Because of high frequency switching, size of the transformer filter units etc. becomes much smaller as compared to thyristor controller power plant

PROCESS FLOW CHART

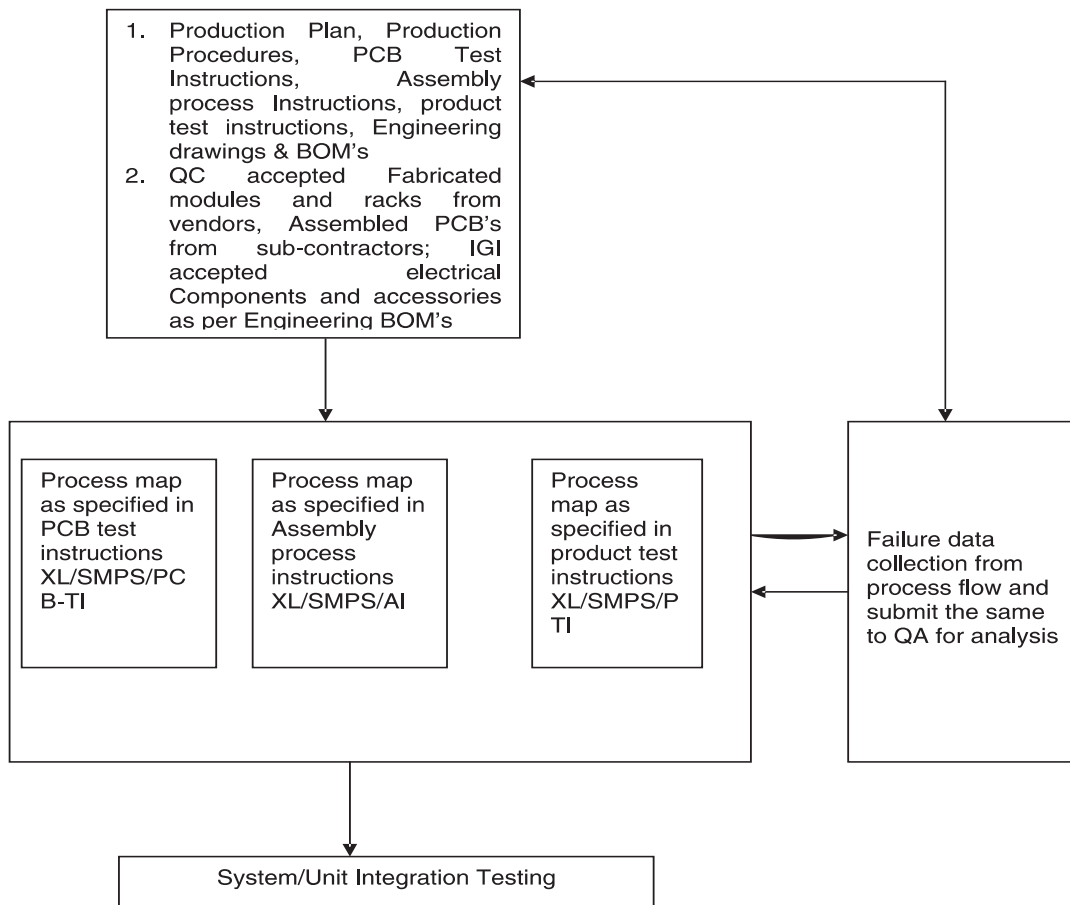



Outside Plant Accessories (Joining Kits, Optic Fiber Accessories, Fusion Splicers etc.)

XL has been supplier of these outside plant accessories for over 2 decades with a Market share of about 40% in Jointing Kit business. However, with the evolution of Mobile segment and growth in the Tele-density in the last 7 years only due to Mobile Penetration, the demand for the company's Jointing Kits has come down drastically. However, with the new thrust for the land line growth by the Telecom Minister from existing 46 Million lines to 70 million lines by 2008, the Company is expected to have reasonable level of revenues, though miniscule compared to over all revenues. In 1990, The Company established manufacturing facility to manufacture Heat Shrink Sleeves, the main component in the jointing Kit, as backward integration project in technical and Financial assistance with the then German major SIEMENS through its subsidiary M/s. RXS Kabelgarniturien GmbH, Germany.

Jointing Kits

Head Factory Operations shall be responsible for over all production activities, which includes Engineering, Assembly, Testing and Inspection of the Product.

Procedure for Jointing Kits

Launching of production Batches and Following up

Allocation of load to different section/stages keeping by weekly plan (XL/JPP/01) keeping in view the Sales Advice Note Availability of material and capacity is done by in-charge production.

PPC Asst. follows up the progress of Job in shops by giving suitable priorities as per the requirement and follows completion. He assists stores in dispatch of consignment to the customer.

Manufacturing process

HS SLEEVES: Manufacturing process for H.S.Sleeve is carried out through a highly automated and dedicated plant employing a number of electrically controlled processes. Once the machine is started, in general the machine is operated continuously without any break, till all the planned production is completed for the type.

Preparatory Operations: After switching sequence is carried out and all set parameters come to required levels, a one meter long unexpected profile is fed into the machine. The QC Inspector for width, thickness without hot melt adhesive coating, foot and rail bend check this production sample.

1 XL/JPP/01 Weekly Production Plan

Process Control: If all parameters are (as per) Table A – of TEC Speef.No.G/CJM – 01/02 June'99 clearance is given by Q.A to start production. The process parameters recorded in the "QA Process Check Register" are set and actual temperatures in different Zones in panel's No.1,2,3 & 17 locations of the extruder. Monitoring of Caron and five voltage levels, chilling water temperature, air pressure and chain speed is done at the beginning and when the pallet is changed. These records are also made in the QC Process Check Register.

Process Inspection Report: While the production is running, approximately every 15 minutes measurements on two sleeves are taken for length, width, thickness, overlap width, overlap thickness – all on the operator's as well as opposite side. Correct printing of batch no. and uniformity of paint application is also checked. All these records are also maintained in the register.



Process Flow Chart – Jointing Kits

H.S. SLEEVES

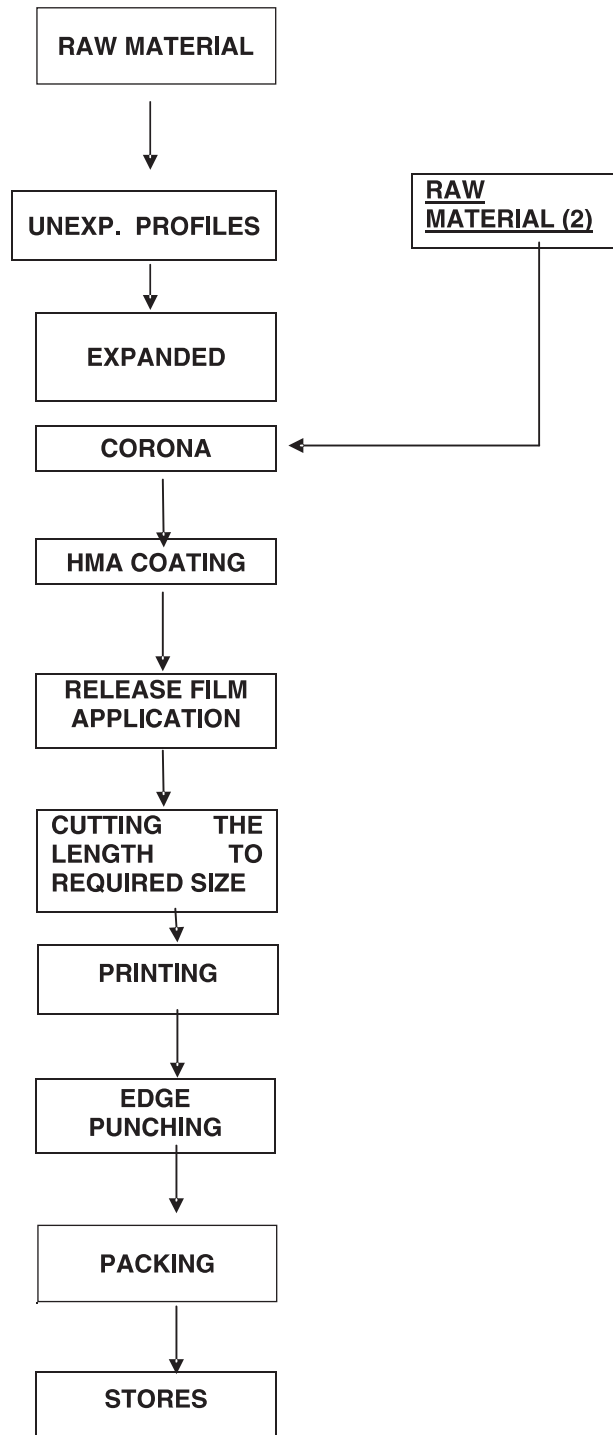



Solar Photo Voltaic Systems

XL has established a Solar Photo Voltaic Module Manufacturing facility in the year 1995. XL has initially has entered into this segment to largely cater to BSNL's Village Public Telephone requirements valued about Rs.25000 Lakhs.

XL is a supplier of these SPV Systems to various Non-Conventional Energy agencies for the past decade and have also export its Modules to various countries.

PROCESS FLOW DIAGRAM

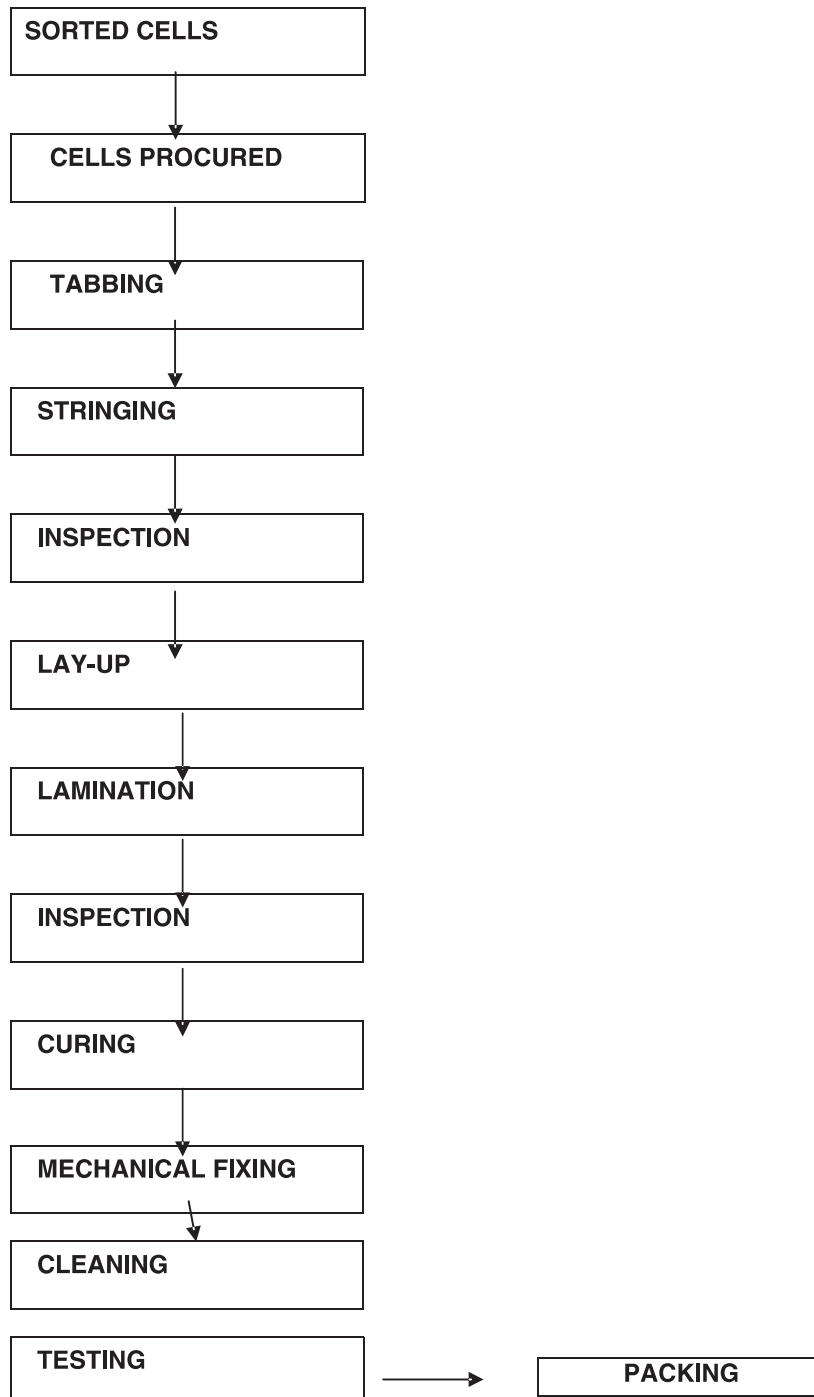



MODULE PRODUCTION PROCESS

CELL SORTING OR TESTING:

This is the process where unsorted solar cells are sorted and if sorted cells are produced they are tested as per relevant IS Specifications and then the material is passed on for production.

Sorting/Testing is carried out with the help of Cell Sorter/Tester

TABBING:

This is a process in which two copper leads are soldered on the bus bars of solar cell. The soldering is done with the help of temperature - controlled soldering irons. Tabbed cells are passed on to stringing.

STRINGING:

Stringing is an operation where the tabbed solar cells are connected in series or parallel as per the requirement of the product. Soldering operation in stringing is carried out with temperature-controlled soldering irons and on stringing jigs made accordingly to the product required.

Facility is available for making around 30 strings of rating 12V, 80Wp per hour.

INSPECTION:

This is the process where the string is inspected for any cell breakage, improper soldering, mis-alignment, polarity. The inspection is carried out on stringing table.

LAY – UP:

This is the process where the cell string is sandwiched between the layers of Toughened Glass, EVA, Cell String, Crane Glass, EVA, Tedlar. This process is carried out on Lay-Up table.

LAMINATION:

This is the process where the cell string is laminated. This process is carried with the help Vacuum Laminator. Per hour around 30 to 35 laminates of rating 80Wp can be done.

After lamination for proper bonding the laminated are cured in curing oven.

MECHANICAL FIXING:

This is a process where extra edges of laminate are trimmed and for protection Aluminum Channels are fixed on four sides. For Output Leads terminal box is fixed.

TESTING:

In this process the I-V Characteristics of the module are tested. This is carried out with the help of Solar Sun Simulator.

PACKING:

This is the process where module is packed in the corrugated box.

ETHANOL

Ethanol is used as an automotive fuel by itself and can be mixed with gasoline to form what has been called 'gasohol'. FUEL ETHANOL – the most common blends contains 10% of Ethanol. Because of the ethanol molecule contains oxygen, it allows the engine to more completely combust the fuel, resulting in fewer emissions. Since ethanol is produced from plants that harness the power of sun, ethanol is also considered a renewable fuel. XL has established manufacturing facility at Nanded, Maharashtra after obtaining the necessary license. XL has the distinction of largest capacity currently in India with 1,50,000 Its capacity per day. XL facilities have been inspected and cleared technically by Oil companies both in terms of capacity evaluation and the quality of the product being produced.



PROCESS DESCRIPTION

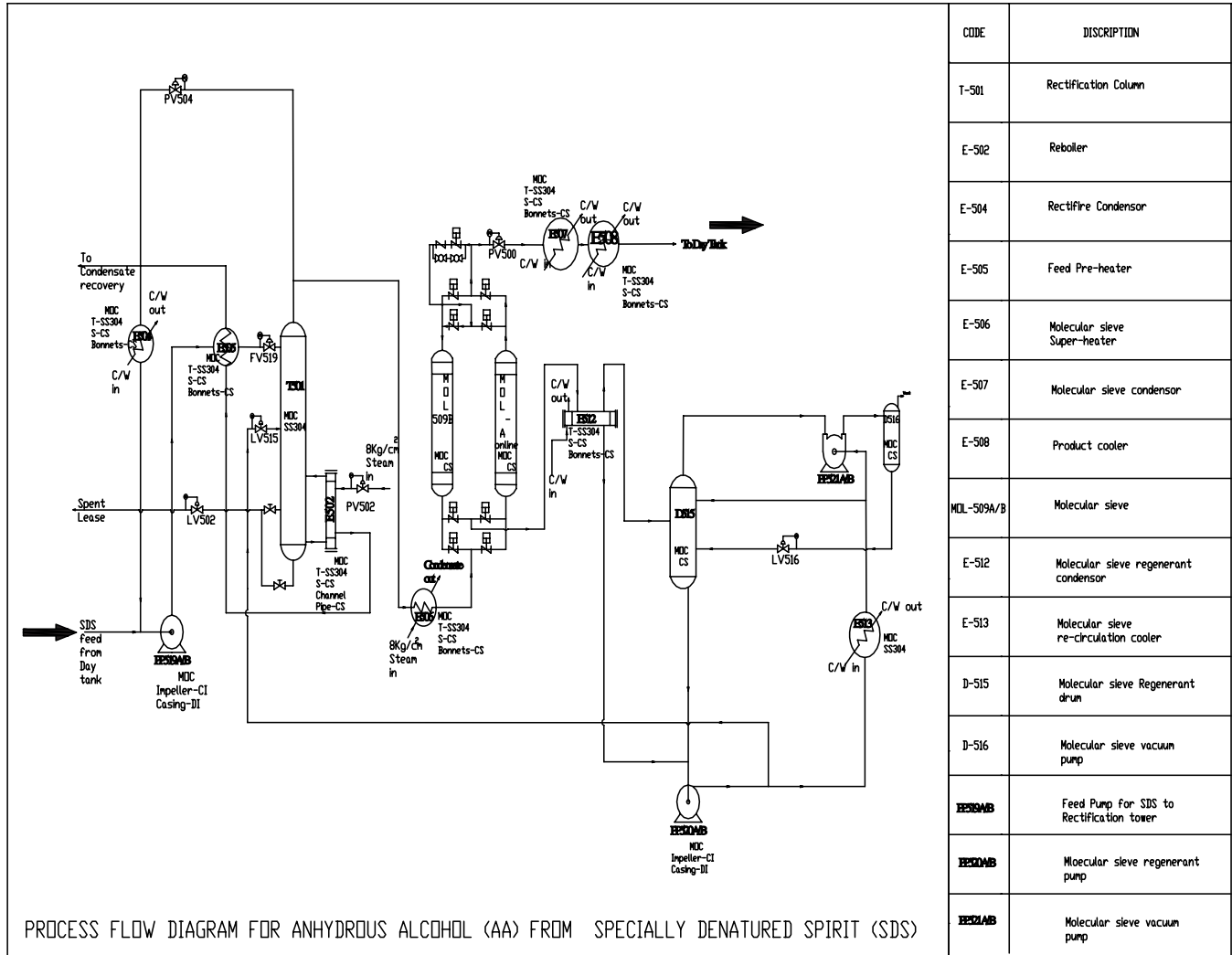

CODE	DISCRIPTION
T-501	Rectification Column
E-502	Reboiler
E-504	Rectifire Condenser
E-505	Feed Pre-heater
E-506	Molecular sieve Super-heater
E-507	Molecular sieve condenser
E-508	Product cooler
MOL-509A/B	Molecular sieve
E-512	Molecular sieve regenerant condenser
E-513	Molecular sieve re-circulation cooler
D-515	Molecular sieve Regenerant drum
D-516	Molecular sieve vacuum pump
E-509	Feed Pump for SDS to Rectification tower
E-510	Molecular sieve regenerant pump
E-511	Molecular sieve vacuum pump

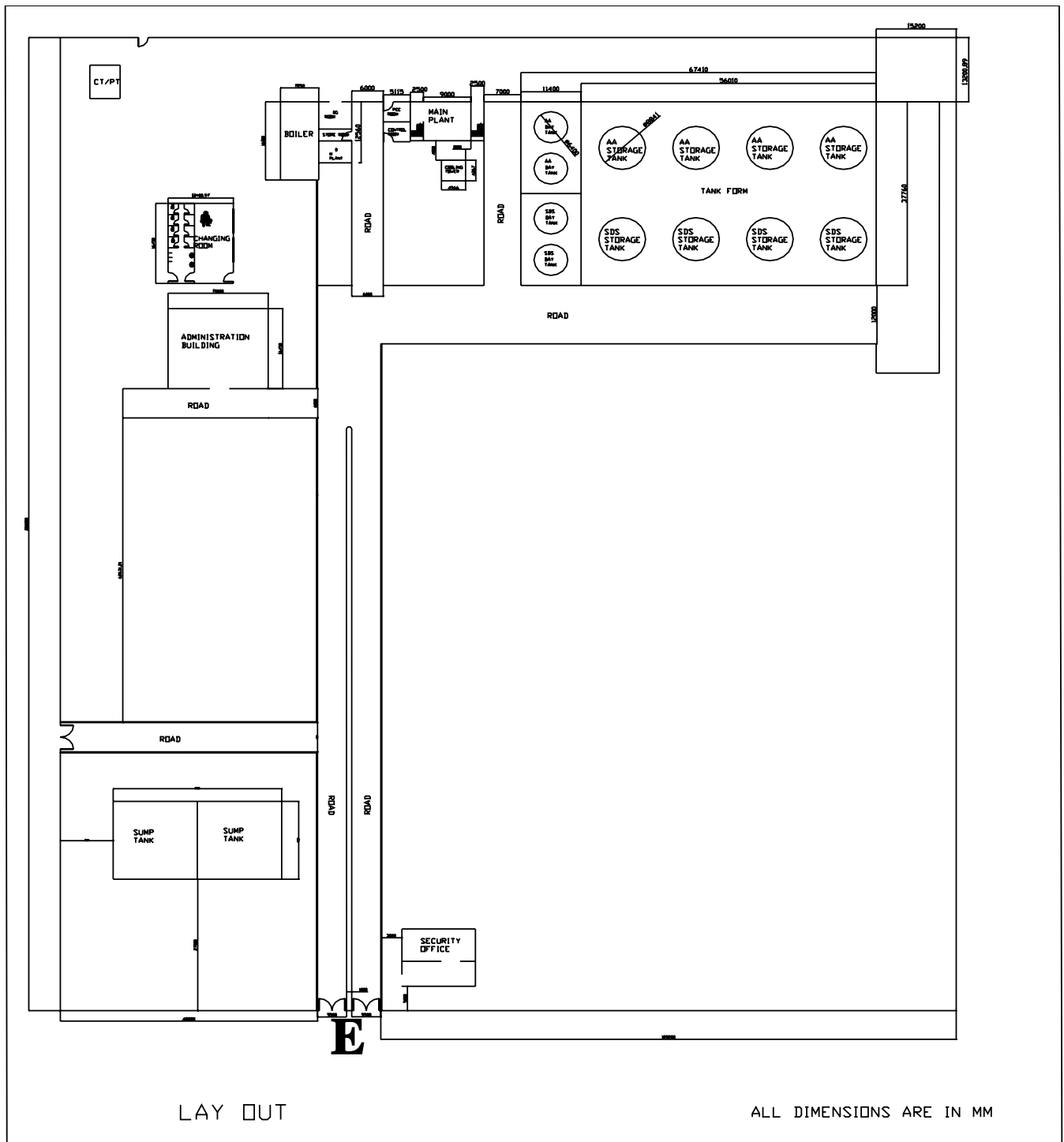



DESIGN BASIS

The factors used to establish the design basis for the vapour phase Molecular Sieve based Dehydration System for Fuel - Grade Ethanol, are as follows:

Anhydrous Alcohol Production, liters/day	1,50,000
Product Quality, % v/v	99.8 min
Feedback RS as per IS323	94.68%v/v, min

PROCESS DESCRIPTION

From feed tank, rectified spirit is pumped to the stripper/Rectifier Column. A partial stream of vapors from the Column are condensed in the Condenser and sent back to the column as reflux. Rest of the vapors are passed through a super heater and taken to the Mol Sieve Units for dehydration. The vapour passes through a bed of molecular sieve beads and water in the incoming vapour stream is absorbed on the molecular sieve beads and water in the incoming vapour stream is absorbed on the molecular sieve material and anhydrous ethanol vapor exits from the Mol Sieve Unit.

Hot anhydrous ethanol vapour from the Mol Sieve Units is condensed in the Mol Sieve Condenser. The anhydrous ethanol product is then further cooled down in the product cooler, to bring it close to the ambient temperature.

The two Mol Sieve Units operate sequentially and are cycled so that one is under regeneration while the other is under operation, absorbing water from the vapour stream, the regeneration is accomplished by applying vacuum to the bed undergoing regeneration. The absorbed water from the molecular sieve material desorbs and evaporates into the ethanol vapor stream. This mixture of ethanol and water is condensed and cooled against cooling tower water in the Mol Sieve Regeneration Condenser. Any uncondensed vapour and entrained liquid leaving the Mol Sieve Regeneration Condenser enters the Mol Sieve Regeneration Drum, where it is contacted with cooled regeneration liquid. The cooled regenerant liquid is weak in ethanol concentration, as it contains all the water desorbed from the Molecular Sieve Beds. This low strength liquid is recycled back to the Stripper/ Rectifier Column for recovering the ethanol. The water leaves from the bottom of the column and contains only the traces of alcohol.

Advantages of the System:

- Minimal labor
- Stable operation
- Near theoretical recovery
- Steam consumption minimized by multi-stage preheating to permit substantial heat recovery and reuse.
- An advanced control system developed through years of experience, to provide sustained, stable, automatic operation.
- Consistent product quality maintained

CONTROL SYSTEM

To get continuous stable and efficient plant operation, PC PLC based microprocessor-controlled operations for continuous monitoring all the critical parameters are provided with proven systems developed in KATZEN Plants and Non-critical parameters are controlled pneumatically.

MARKETING OPERATIONS

XL has established marketing team with high energy and competency. The Company is having different marketing setup and teams for different product segments:

1. CDMA, FWP – Tender Based Marketing to PSUs

The Company has focussed approach to large established PSU Telecom operators like BSNL and MTNL. These PSUs normally go through the Tender Based approach for procuring their requirements. Also the products need to go through the type-approval procedure to be eligible to participate in the Tenders. Company's Marketing wing is headed currently by Vice President to look after this business located out of New Delhi. XL has been very successful in this business model and currently secures about 40% of 2005 revenues through this business model. XL works very closely with the Foreign Partner in deciding the competitive price. Company leverages the duty advantage it derives by having assembly facility. The Vice President is ably supported by Marketing Managers and Executives and takes the Direction from the Working Board.



2. CDMA – Direct Marketing to Private Carriers

XL works with several Private Carriers both nationally and internationally for sale of CDMA handsets and Company's Technical Director deals directly in this market with customers. The volumes are very large and normally they work in close association with Foreign Partner in this product segment in view of volumes and pricing decision required. XL has supplied material to almost all the operators, while TATA Indicom being the leader in procuring Company's handsets.

3. CDMA – Retail Marketing (OPEN MARKET OPERATIONS)

The fast growing CDMA handset market is not surprisingly evolving from a purely operator-centric market to one where the retail market is significant. At present majority of handsets are sold by the operators to end customers by buying from the vendors like XL (Kyocera), LG, Samsung and Nokia. That's because till recently CDMA phones had to be activated at the factory itself or at an operator-specified center. That's very unlike GSM phones that could be activated at the point of sale with SIM (Subscriber Identity Module) chip.

Thus for some time after CDMA services were launched, subscribers wishing to change phones discovered that they would have to change number too. That has since changed.

This also hampered the growth of an effective second-hand market. Unlike the GSM space where secondhand sets are available even for Rs.1000-2000. CDMA handsets could be bought from the operator only.

On the entry of companies like Nokia, retail sales grew. And Reliance Infocom worked to create a secondary market for CDMA handsets. The Company setup a special team to spearhead the development of a second-hand market. "A huge stock of used handsets is available in the market as many RIM subscribers have begun to upgrade their handsets".

Seeing the opportunity, XL-Kyocera jumped immediately at the opportunity and has established tie-up with Reliance to access their entire retail outlets of approximately 10,000. XL has created distribution and channel network across the country in multi layer fashion to ensure reaching the customers through these retail outlets.

Similarly XL has also entered into an exclusive agreement with MTNL for an year to do retail sales through their 'Sancharnet' outlets in Delhi and Mumbai.

Similarly XL has initiated talks with TATA Indicom and has reached in principle agreement to access their retail outlets and channel partners and we expect the business to take off in the second half of 2006.

A Vice President with back ground of retail model and experience in Carriers like Reliance has been hired to look after this business exclusively with backend support from Managers and Executives.

XL has innovatively created distribution channel, who are already in this business and have been working the retail outlets of Mobile Phones, so that there is no wastage of time.

4. SMPS, Outside Plant Accessories and Solar Systems

Company has established brand image and acceptability with almost all customers in these product segments in view of its tremendous track record of quality and right priced products in this segment. Company goes through both Tender Marketing model and direct marketing approach for all these products. A senior Vice President handles the job along with a General Manager, Marketing and several Executives. Having established several marketing processes, which has lead to success of the company, going forward Company sees continuing the aggressive marketing approach.

5. Ethanol – Tender Based Marketing to PSUs Direct Marketing to Others

The Company has focussed approach to large established PSU OIL Companies like IOC, HPCL, BPCL etc.,. These PSUs normally go through the Tender Based approach for procuring their requirements and that too Region wise Tenders. Also before the bids are opened these PSUs normally visit the company and evaluate the capacity, despite the Licensed and Installed capacity - XL has gone through this process and has become eligible in all these criteria and has become eligible to participate in the Tenders. Company's Marketing wing is headed currently by Vice President to look after this business located out of Mumbai. XL has been successful in this business model and currently secured orders for over Rs.10000 Lakhs to be supplied over next 12 months. Company leverages the duty advantage it derives by having manufacturing facility and the one of the largest capacity of 150,000 ltrs per day of manufacturing to get larger business. The Vice President is ably supported by Marketing Managers and Executives and takes the Direction from the Working Board.



Exports

As mentioned earlier, XL has so far concentrated on the domestic market and to a limited extent export market for the CDMA Handsets as per the agreement with Kyocera. However, it has identified exports as one of the major thrust areas for growth. As per the business plans, the exports will contribute approx. 20% of the total turnover by FY 2007 from approx 10% in FY 2005. As discussed the Solar Plant should focus exclusively on Exports to Europe and the Company should continue to see good exports possibility to African, Middle East and other neighboring countries for CDMA products like Mobile Handsets and Fixed Wireless Phones. However, the company is not under any obligation for export of its products.

Business Strategy & Future Prospects

The company has been a supplier in several Telecom Products it has chosen to be in for several years. The Company's strategy has been to concentrate in the domestic market as a preferred Quality Telecom Equipment supplier. The company has consciously focused on the Telecom Sector which has been seeing unprecedented growth compared to world markets or any other sector with in India.

As already discussed in earlier, Telecom Sector continues to see exciting days and particularly in the areas XL has focus. XL focus in CDMA Mobile segment should help the company to grow faster than the Industry Average in the next five years especially with its expansion plans to get into Open Market initially and then in introducing Fixed Wireless Phones in Indian market from its Technology Partners.

XL has decided to consolidate domestic operations in the CDMA Handsets and FWP categories in the current year and then focus aggressively Export Segment in the neighbouring, African and Middle East Markets.

XL has grown at CAGR of over 100% during the last 3 years in terms of sales. XL has adopted multi-pronged strategy to drive future growth, which would be through the following:

- I. Expansion – Solar Photo Voltaic Modules
- II. Retail Market Initiative in CDMA Handsets
- III. New Products – Fixed Wireless Phones
- IV. Exports – CDMA Handsets, SPV Modules

I. Expansion

EOU for Solar Systems

XL has embarked on the expansion plans in Solar Systems for Export Market. This segment should contribute substantially for Companies Export Targets over next 3 years especially with its committed customers and signed contracts.

II. Retail Market initiative in CDMA Mobiles

XL has been preferred supplier for Telecom Operators like TATA Indicom and enjoyed high degree of success with Public Sector Units like BSNL and MTNL. To achieve the goal of being the preferred supplier to largest CDMA Operator Reliance, XL has adopted innovative strategy and tied up with them to launch their High-end Mobile Handsets in their Open Market Operations, which in turn will enable XL to get into Retail Distribution Network in the long run.

Similarly XL has become only vendor with MTNL for their Open Market Operations.

III. New Products

One of the major products, which have been identified for launch in the current year, is Fixed Wireless Phones – A emerging and growing Market. As already discussed the product has opportunity and the Market demand is estimated about 8 Million Phones in the coming year.

XL is establishing the assembly plant with SMT Line. The SMT Plant will have a capacity to produce 10,000 pieces per day and about 3 Million pieces per annum, while there are no constraints in assembling the product with import of components on CKD/SKD basis.

As already presented earlier the product has good demand and the procurement in the last year from Private Operators alone being 2.8 Million Handsets, without taking BSNL and MTNL procurements.



Capacity and Capacity Utilization

Mobile Handsets

XL has established 3 Assembly lines with a capacity of about 10,000 Handsets per day. The annual capacity works out more than 3 Million Handsets.

Ethanol

XL has the Country's largest manufacturing plant with a capacity of 1,50,000 liters per day.

H S Sleeves

XL has the capacity to Produce over 20,00,000 Heat Shrink Sleeves per annum as assessed by Department of Telecommunications

Quality Control Systems

XL has adopted stringent quality control systems. In December 1995, XL received ISO 9002 certification for the Quality Control.

The details of Licenced, Installed and Utilised Capacities & Production are given below:

Name of the product	Licensed capacity	Installed capacity	Actual Production			
			2005-06	2004-05	2003-04	2002-03
1. Cable jointing Kits	500000	500000	175239	159339	48380	123373
2. SMPS Plants	2880	2880	510	969	618	810
3. Solar Modules	1 MW	1 MW	120KW	98 KW	80KW	102KW
4. CDMA Phones	3000000	3000000	738415	522961	371358	67425

COMPETITIVE STRENGTHS

Successful Long Term working relationship with Foreign Technology Partners

The company enjoys confidence from its Technical Partners. This is evident with long term relationships the Company has enjoyed with various Multinationals like SIEMENS-Germany, CORNING-USA, Kyocera – USA & Japan and Axesstel of USA etc., Further SIEMENS had invested in the company for a long period up to 30%, which was acquired by promoters, due to defocus of SEIMENS from this product segment.

Customer Relationship with Telecom Operators

XL has a track record for good relationship over 20 years with country's Public Sector Operators like BSNL and MTNL. Leveraging these relationships XL has diversified and expanded its product portfolio from single product Jointing Kit in 80's and 90's to Solar Systems, SMPS and CDMA Handsets in the following decade.

XL enjoys similar relationship with Private Telecom Operator TATA Indicom, resulting about 50% market share in their Handset Procurement till date. XL has established relationship with another player RELIANCE INFOCOM and has established distribution network to enter into 'OPEN MARKET OPERATIONS' through the retail outlets of Reliance. XL has started the retail business since Dec 2005.

Low Cost Operations

Continuous improvements in the areas of quality, cost innovation have enabled company to continuously improve quality and reduce cost. XL has been continuously evaluating and innovating methods to cut down cost. Some of the areas the company has focused on for cost reduction are improved processes, vendor rationalization, and employee participation for suggesting areas of improvement.

High Quality Production Facilities

XL has adopted stringent quality control systems. XL is ISO 2000 certified company. The company focuses on quality at every stage right from receipt of raw material through process to finished product. XL enjoys high degree of confidence for its products from all its customers and in particular BSNL & MTNL. These PSU organizations have in fact have further granted self clearance method for company's dispatches due to its quality systems.



Government of India Policy Decision for Mandatory Blending of Ethanol up to 5%.

Government of India has made it mandatory currently for 9 States and Four Union Territories to blend Ethanol up to 5% in Petrol and Diesel at Distribution Points. This helps substantially for the Company's product Ethanol. We do expect this percentage to go up by another 5% in times to come and then expanding the application to other states as well.

SWOT ANALYSIS

STRENGTHS

- Business dealings with BSNL and MTNL for the past two decades
- TATA Relationship for last two years
- Successful Technical partnership with overseas partners who are the pioneers in technology
- Leveraging Customers for Product Portfolio Expansion & Growth

WEAKNESSES

- Substantial dependency on Government Business – BSNL, MTNL and Oil Companies
- Business only through public tendering from Government Companies.
- Dependency on Technology partners for innovation
- No internal R & D

OPPORTUNITIES

- Shift of MTNL/BSNL/Private Operators focus from wire line to wireless technology.
- Blending requirements for ethanol with petrol expected to increase to 10% from the current 5% level. Policy to be made mandatory all over India as respect to its current applicability in 9 states.
- GOI to introduce blending policy of ethanol to diesel also

THREATS

- Government's policy for relaxation of imports of telecom products

Manpower

Company's existing manpower as on March 31, 2006 is 275.

Insurance

The Company has insurance policies of the following nature:

1. Insurance of standard fire, burglary and special perils policy for furniture, fixtures and fittings, building(s), electrical & fittings in the office premises
2. Burglary & standard fire and special perils policy for stock
3. Overseas Leisure Travel Insurance
4. Marine Cargo (Open Policy for stock)-Inland
5. Transit Insurance

The Insurers of the Company are

	Insurance Company	Address
1.	The New India Assurance Co. Ltd.	Parklane, SD Road, Secunderabad – 500 003



Details of Insurance on Stocks and Fixed Assets

SL No.	Description	Sum Insured	Policy No.
1	Fixed Assets at Cherlapally	780.00	612400/11/06/11/188
2	Raw Material & Finished goods at Cherlapally	4650.00	612400/11/06/11/186
3	Stock in Process at Cherlapally	350.00	612400/11/06/11/191
4	Fixed Assets at Mallapur	1001.00	612400/11/06/11/189
5	Stocks At Mallapur	100.00	612400/11/06/11/190
6	Fixed Assets at Ethanol Factory- Nanded	700.00	612400/11/06/11/192
7	Cash in Transit	100.00	612400/48/06/07/114
8	Furniture&Fixtures, Electrical Fittings (including Ac's, Computers) at 335,336 529,&540 3rd &5th Floors Chandralok complex Secunderabad.	75.00	612400/11/06/11/187
9	Stocks at Nanded Ethanol Factory	550.00	612400/11/06/11/193
10	Goods in Transit-Ethanol(outgoing)	700.00	612400/21/06/02/53
11	Goods in Transit - Marine Policy	12600.00	612400/21/06/02/53

Property

Details of the Properties Owned by the Company:

Land and Buildings:

S.No.	Particulars	Area	Location
1	Industrial Shed	2241.30 Sq.Yds / 1874 Sq.Mts together with the shed admeasuring 30' X 60' having a plinth area of 2017.30 sq. Fts.	Shed No. 30, IDA, Mallapur, Ranga Reddy District.
2	Industrial Shed	1415.50 Sq.Mts with plinth area of 2017.30 sq.fts	Shed No. 32, IDA, Mallapur, Ranga Reddy District
3	Industrial Shed	1557.70 Sq. Mts. with the plinth area of 2017.30 sft	Shed No. 31, IDA, Mallapur, Ranga Reddy District
4	Industrial Plot	Plot No. 198/A admeasuring 9000 Sq.Mts	Plot No. 198/A, Phase II, IDA, Cherlapally, Hyderabad
5	Industrial Plot	Plot No. 198/B admeasuring 9000 Sq.Mts	Plot No. 198/B, Phase II, IDA, Cherlapally, Hyderabad



Details of Properties acquired on lease

Sl. No.	City	Branch Address	Landlord	Area Covered	Period of Lease	Lease Deposit Rs.
1	Kolkata	AA7, Prafulla Kanan (W), P.S. Rajarhat, Kolkata – 700 101	Anima Dasgupta, W/o. Sri Badal Dasgupta	Ground Floor at AA7, Prafulla Kanan (W), P.S. Rajarhat, Kolkata-700101	24 months 01/05/2005 to 30/04/2007	10,000/- (Rupees Ten Thousand Only)
2	Ranchi	Ward No. VI, Municipal Holding No. 1699C, Kailash Babu Street, Ranchi	Subash Chandra Agarwal	A Shop Room admeasuring 8' x 13' at the Ground Floor	11 Months 01/11/2006 To 30/09/2007	6,000/- (Rupees Six Thousand Only)
3	Patna	Office No. 110, First Floor, R.P. Tower, Fraser Road, Patna.	Suman Tripathy	Office No. 110, First Floor.	11 Months 01/10/2006 To 31/08/2007	4,200/- (Rupees Four Thousand Two Hundred Only)
4	Bhubaneswar	47, Madhusudan Nagar, Bhubaneswar, Orissa	Shri Sourendra Kumar Mohapatra	House at 47, Madhusudan Nagar, Bhubaneswar Orissa	1 Year From 01/10/2006 To 30/09/2007	4,500/- (Rupees Four Thousand Five Hundred only)
5	Thiruvananthapuram	TC 28 /176, Thundathil House, Kaithamukku, Thiruvananthapuram – 695 024	Madhu S	Building bearing TC 28/176	11 Months From 01/07/2006 To 31/05/2007	20,000/- (Rupees Twenty Thousand Only)
6	Raipur	Chandankunj, Naharpara, Raipur – 492009	Jayaram Jhabada	Chandankunj, Naharpara, Raipur – 492009	11 Months From 01/10/2006 To 30/09/2007	5,000/- (Rupees Five Thousand Only)
7	Nanded	Plot Nos. 8-8,9,20,21 & Plot Nos.8-10,18,19 M.I.D.C., Kushnoor, Industrial Area, Maharashtra	Maharashtra Industrial Development Corporation	Plot Nos. 8-8,9,20,21 admeasuring 20000 sqm. & Plot Nos. 8-10, 18,19 admeasuring 14000 sqm.	95 years From 01/11/2003	8,50,000/- (Rupees Eight Lakh and Fifty Thousand Only)
8	Secunderabad	335, 3 rd Floor, Chandralok Complex, S.D. Road, Secunderabad.	Syed Nooruddin,	335, 3 rd Floor, Chandralok Complex, S.D. Road, Secunderabad	3 Years From 01.12.1999 with an option to renew authomatically unless otherwise teminated in writing.	Nil
9	Mumbai	No. 105, Centre Point, J.B. Nagar, Andheri – Kurla Road, Andheri (E), Mumbai-400059	Murugan Shipping Private Limited		11 months From 01/03/2006 to 31/01/.2007	5,00,000/- (Rupees Five Lakhs only)

Purchase of Property

The Company does not propose to purchase or acquire any property in current financial year or from the proceeds of the present issue.



KEY INDUSTRY REGULATIONS & POLICIES

We are in the business of manufacturing and selling of Telecom Equipment and Ethanol in India. In Telecom we deal largely with CDMA Mobile Handsets, Fixed Wireless Phones, Switch Mode Power Systems, Joining Kits and Optic Fiber Accessories. In India Telecom Business in general is regulated by Department of Telecommunication, Ministry of Communications & Information Technology, Government of India.

Telecom:

The prime act which governs services of the company is The Indian Telegraph Act, 1985 and Indian Wireless Telegraphy Act 1933. The government has announced National Telecom Policy in 1994 to improve quality of telecommunications services in India. Subsequently the government has announced new National Telecom Policy in 1999 to further boost the satellite communication in India. The New Telecom Policy 1999 envisages grant of license on non-exclusive basis to VSAT service providers for a period of 20 years extendable one time by 10 years. Accordingly, licenses are issued to applicants to establish, install, operate and maintain VSAT Closed Users Group (CUG) domestic data network service via INSAT satellite system on non-exclusive basis within territorial boundary of India.

However, there are no specific regulatory issues relating to the manufacturing of Equipment are concerned and largely the policies and regulations are more towards the Operators who provide service to the customers. Our Equipment are largely go to either service providers or to the end users (CDMA Phones) again either through the Carriers or directly.

Further to promote the domestic manufacturing, Government of India has given concessional 0% duty on import of components for manufacturing of Mobile Phones,

Ethanol:

Ethanol manufacturing in India is governed by State Government Policies and currently we have our facilities in Nanded, Maharashtra, where we have obtained License to produce Ethanol. Hence, in general we are governed by the State Excise Rules and regulations.

Further to promote domestic production of Ethanol Government of India has issued the notification vide P-45018/28/2000-C.C- dated 3rd September, 2002 by Ministry of Petroleum and Natural Gas, which is reproduced as under;

THE GAZETTE OF INDIA: EXTRAORDINARY [PART I- SEC. I]
MINISTRY OF PETROLEUM AND NATURAL GAS RESOLUTION
NEW DELHI, 3RD September, 2002 No. P-45018/28/2000-C. C. -

With a view to give boost to agriculture sector and reduce environmental pollution, Government of India have been examining for quite some time supply of ethanol-doped-petrol in the country. In order to ascertain financial and operational aspects of blending 5% ethanol with petrol as allowed in the specifications of Bureau of Indian Standards for petrol. Government had launched three pilot projects; two in Maharashtra and one in Uttar Pradesh during April and June 2001 and these pilot projects have been supplying 5% ethanol-doped-petrol only to the retail outlets under their respective supply areas since than. Apart from the aforesaid field through pilot projects, R & D studies also were undertaken simultaneously. Both pilot projects and R & D studies have been successful and established blending of ethanol up to 5% with petrol and usage of ethanol-doped-petrol in vehicles.

Discussions were held with concerned agencies including the Governments of major sugar producing States. While the Society for Indian Automobile Manufacturers (SIAM) has confirmed the acceptance for use of 5% ethanol-doped-petrol in vehicles. State Governments of major sugar producing States and the representatives of sugar/distillery industries have confirmed availability / capacity to produce ethanol. Government have set up an Expert Group headed by the Executive Director of the Centre for High Technology for examining various options of blending ethanol with petrol including use of ETBE in refineries. Considering the logistical and financial advantages, this Group has recommended blending of ethanol with petrol at supply locations (terminals / depots) of oil companies. In view of the above, Government have now resolved that with effect from 1-1-2003, 5% ethanol-doped-petrol will be supplied in the following nine States and Four contiguous Union Territories :

States & Union Territories: Andhra Pradesh, Damman and Diu, Goa, Dadra and Nagar Haveli, Gujarat, Chandigarh, Haryana, Pondicherry, Karnataka, Maharashtra, Punjab, Tamilnadu & Uttar Pradesh



HISTORY AND CORPORATE STRUCTURE

XL Telecom was incorporated as XL Cable Splices Pvt. Ltd on 3rd October 1985, with the main objective of carrying on the business as manufacturers and dealers in cable splices, manufacturers of protection equipment and allied accessories for Electronic Telephone Exchanges and other establishments. Since the Company was getting into telecom line, the name of the Company was changed to XL Telecom Private Limited on 18th December, 1985. The Company was subsequently converted into a Public Limited Company by the name of XL Telecom Limited on 31st December 1990.

XL initially focussed in Outside Plant accessories and more specifically Jointing Kits for PIJF Cables in the year 1985.

In 1990, the company established manufacturing facility to manufacture Heat Shrink Sleeves, the main component in the Jointing kit, as backward integration project in Technical and Financial assistance with the then German Major SIEMENS through its subsidiary M/s RXS Kabelgarniturien GmbH, Germany.

In the year 1995, XL established a Solar Photo Voltaic Module Manufacturing facility. XL initially entered into this segment largely to cater to BSNL's Village Public Telephone Requirements.

In the year 2000, XL established facility to manufacture SMPS Power System in technical assistance with SMPS De Austria.

In the year 2002, XL diversified into fast growing Indian Mobile segment and of it then emerging CDMA Mobile Market in Technical assistance with internationally renowned market leader Kyocera.

Background

1. Originally incorporated as a Private Limited Company under the provisions of the Companies Act 1956 on 3rd day of October, 1985 as "XL Cable Splices Private Limited" from The Registrar of Companies, Andhra Pradesh at Hyderabad and subsequently converted to "XL Telecom Private Limited" and was subsequently converted to "XL Telecom Limited" vide fresh Certificate of Incorporation dated 31st Day of Decembar 1990 from The Registrar of Companies, Andhra Pradesh at Hyderabad with the main object of manufacturers and dealers in cable splices, manufacturers of protection equipments and allied accessories. Important Events in the History of XL Telecom Limited are:

Year	Event
1985	Incorporated on 3 rd Day of October of 1985
1985	Changed its name to "XL Telecom Private Limited" with effect from 18 th December, 1985
1987	Mr. Dinesh Kumar, the present Managing Director and promoter joined the Company as a Management Executive
1990	Converted into a public limited Company and obtained fresh certificate of Incorporation
1990	The Company established manufacturing facility to manufacture of Heat Shrink Sleeves, the main component in Jointing Kit.
1992	The Financial Institutions, ICICI, IDBI and IFCI invested in the Equity of the Company to the tune of Rs. 1,00,00,000/-
1992 & 1993	RXS, the Technology provider, invested in the Equity of the Company to the tune of 994296 Equity Shares of Rs. 10/- each at par value
1995	Established a Solar Photo Voltaic Module manufacturing facility.
1998	Mr. Dinesh Kumar has been co-opted on the Board
1999	Mr. Dinesh Kumar has been elevated to Deputy Managing Director of the Company
2000	Established a facility to manufacture SMPS Power System with SMPS De Austria
2000	Death of original promoter Mr. Sunder Lal
2000	Management of the Company has been acquired by Mr. Dinesh Kumar, the then Deputy Managing Director
2002	Tie up with M/s. Kyocera Wireless Corporation, USA for setting up assembly facilities for CDMA handsets, subsequently altered Main Objects to enable the Company to carry on the business as manufacturers and dealers in CDMA/GSM Mobile Stations
2003	Altered its Main Objects to enable the Company to diversify into the manufacture of Ethanol with a total capital outlay of Rs. 550 Lakhs



Changes in the Memorandum of Association of the Company

Since incorporation of the Company, the following changes have been incorporated in the Memorandum, after approval of the Members:

Particulars	Date of Meeting	Type of Meeting
<u>Insertion of new Clause 41 under Incidental Objects of the Company</u> 41) To invest and deal with the monies of the Company not immediately required in such manner as may from time to time, be determined by the Board of Directors in other Companies, Firms, Bodies Corporate, other business associations including Societies, Trusts and other bodies of whatever nature	05-06-2001	EGM
<u>Insertion of new Clause (6) under Main Objects of the Memorandum of Association of the company:</u> 6) To carry on the business as manufacturers and dealers in CDMA / GSM Mobile Stations, and CDMA/ GSM Infrastructure Equipments, SMPS Power Plants and Allied Equipments including ancillary telecom equipment for outside and inside plant network."	03-10-2002	EGM
<u>Alteration of Main objects clause of MOA u/s 16, 17, 18 by substituting the following new Sub-Clauses (7) & (8) after the present Sub-clause (6) of Clause III (A):</u> 7) To carry on the business of manufacture, produce, process, compound, formulate, condense, distill, commercialize, refine, purify and to act as broker, agent, stockist, distributors, buyer, seller, supplier or otherwise to deal in Petro-chemicals, Organic, inorganic, industrial, pharmaceutical and other chemicals and to do all necessary acts and things incidental for the attainment of the above objects. 8) To carry on business of, and establish Business Process Outsourcing services, Call Centre Services, Training, IT enabled services and other services in the field of Information Technology."	01-10-2003	EGM

Changes in Registered Office of our Company

The table below shows the changes in the Registered Office since incorporation:

Previous Address	New Address	Reasons for Change in Office	Date of Change
A1/3, Chandralok Complex, S.D.Road, Secunderabad-500 003, Andhra Pradesh.	335, Chandralok Complex, S.D. Road, Secunderabad – 500 003, Andhra Pradesh	Convenience	18 th May, 1987

Key Customers

Company is providing services to the corporate enterprises and institutions including public offices. The following are some of the esteemed direct-clients of the Company acquired against multiple service lines:

- Bharat Sanchar Nigam Limited (Department of Telecommunications), Government of India
- Mahanagar Telephone Nigam Limited
- Indian Railways
- Departments of Defence
- Telecommunications Consultants of India Ltd.
- State Nodal Agencies of the Ministry of Non-Conventional Energy Sources
- Private sector companies
- Reliance Infocom, TATA Indicom
- Motorola, Nortel, Siemens, Ericsson
- HPCL, BPCL, IOC, Reliance Industries Limited



Main Objects of the Company

The main objects of the Company as given in the Memorandum of Association of the Company are reproduced below:

1. To carry on the business as manufacturers and dealers in cable splices, and other accessories.
2. To carry on the business as manufacturers of protection equipment and allied accessories for Electronic Telephone Exchanges and other establishments.
3. To carry on the business as manufacturers and Dealers in Computer Hardware, Computer Software, Computer Stationery, Computer peripherals and other components connected with Computers.
4. To carry on the business as technical consultants and project engineers by providing consultancy services.
5. To carry on all kinds of commission Agency and to act as selling agents, buying agents, C&F agents, dealers and stockiest for goods, produce, articles and services of any kind.
6. To carry on the business as manufacturers and dealers in CDMA / GSM Mobile Stations and CDMA / GSM Infrastructure Equipments, SMPS Power Plants and Allied Equipments including ancillary telecom equipment for outside and inside plant network.
7. To Carry on the business of manufacture, produce, process, compound, formulate, condense, distill, commercialize, refine, purify and to act as broker, agent, stockiest, distributors, buyer, seller, supplier or otherwise to deal in Petro-Chemicals, organic, inorganic, industrial, pharmaceutical and other chemicals and to do all necessary acts and things incidental for the attainment of the above objects.
8. To carry on business of, and establish Business Process Outsourcing Services, Call Centre Services, Training, IT enabled services and other services in the field of Information Technology.

Company's Subsidiaries

Company does not have any subsidiary.

Shareholders Agreements

2i CAPITAL PCC, a company incorporated under the laws of the Republic of Mauritius and having its registered office at IFS Court, Twenty Eight, Cybercity, Ebene, Mauritius, and which is an entity registered with the Securities and Exchange Board of India as a Foreign Venture Capital Investor entered into a shareholders agreement dated May 1st, 2006 with XL Telecom Limited, a company incorporated under the Companies Act, 1956 and Mr. Dinesh Kumar and Snehalata Lal Family Welfare Trust and thereby acquired by way of subscription 10,00,000 Equity Shares at a premium of Rs. 90/- per share for a total consideration of Rs. 10,00,00,000/- (Rupees Ten Crores only) constituting 9.48% of the total Equity share capital of XL Telecom Limited (i.e. the pre-issue share Capital) by passing a necessary resolution of the members under section 81 (1A) of the Companies Act, 1956.

Further as per the agreement if prior to the listing of the Company, the Promoter Shareholders proposes to sell any shares held by them, such shares shall be offered to 2i Capital PCC upto acquiring of 15% of the equity capital of the Company, with a right and not an obligation to purchase such shares within seven days of the date of the receipt of the offer notice.

Further 2i CAPITAL PCC has also right to nominate one director on the Board of Directors of the Company as long as it continues to hold atleast 3% of the equity capital of the Company. There shall be an affirmative vote of the nominee Director nominated by 2i CAPITAL PCC regarding alteration of rights, acquisition of assets, Merger and Demerger, any amendments / modifications to the Memorandum of Association / Articles of Association and substantial funding of new unrelated activities.

The Company, its Shareholders and Promoters shall take best endeavours to ensure that the Company will take steps to obtain listing no later than 12 months either by way of further equity to be issued by the Company or by way of an offer to Sale.

Further as per the Agreement the obligations of the Promoters and the Shareholders will cease to exist in the event the Promoters/ Shareholders sell and transfer the controlling interest and management of the Company to any third party, provided however that the Promoters/ Shareholders has offer the rights under the agreement affirmatively.

Financial / Strategic Partners

NIL

Other Agreements

The Company has entered into several Licensee Agreement/Partnerships and/or technology tie-up with International corporations like:



- 1 RXS Schrumpftechnik Garnituren GmbH, a 100% Subsidiary of SEIMENS – Germany
- 2 Corning – USA
- 3 Kyocera – USA & Japan.
- 4 Axesstel – USA

Of the above currently, XL deals with mainly two Companies – Kyocera and Axesstel

Major terms & conditions of the Agreement.

1. To manufacture the CDMA mobile Phones or FWP in India on CKD/SKD basis.
2. To supply the Phones to largely Public Sector Companies like BSNL and MTNL
3. To work along with Foreign Partner for sales to private carriers like TATA Indicom and Reliance Infocom and supply the material with local assembly.
4. To co-ordinate with DoT for the Type Approval of the Partner's products
5. To establish the retail business model in India for thePartner's products



OUR MANAGEMENT

The Company is a professionally managed organization. The Company functions under the control of a Board consisting of both promoter and professional Directors. The day-to-day matters are looked after by qualified key personnel, under the supervision of the Managing Director.

Board of Directors

Name, Fathers Name, Designation and Address	Date of Birth	Qualification	Other Directorship	Shares Held	Remuneration* (Rs. Lakhs) (2004-05)
Dr R Srinivasan Non-Executive Chairman S/o. Late Raghavachari C-6-1, Lloyds Garden, Appa Saheb Marathe Marg, Prabhadevi, Mumbai – 400 025 Occupation: Consultant	30-05-1931	Ph.D in Banking & Finance	a) Beeyu Overseas Ltd. b) Elder Pharmaceuticals Ltd c) Graphite India Ltd. d) Goldiam Intl. Ltd. e) Hi Tech Pharmaceuticals Pvt. Ltd. f) JM Financial Asset Management Pvt. Ltd. g) StorePerform Technologies India Pvt. Ltd. h) Shalimar Paints Ltd. i) Williamson Magor & Co. Ltd. j) Nayamode Solutions Pvt. Ltd. k) Snowcem cements Private Ltd. l) Solar explosives Ltd., Nagpur.	—	—
Mr. Dinesh Kumar Managing Director S/o. Late Col. Venkata Ramana Krishna Kumar Plot No.1, Lalita Nagar, Wellington Road, Westmarredpally, Secunderabad Occupation: Business	23-12-1963	B.Com	SoftProjex (India) Limited	14,91,290	150
Mr. K. Vasudeva Rao Executive Director S/o. K.L. Narayana301, Prithvi Mansions, Badami Galli, Domalguda, Gaganmahal, Hyderabad -29 Occupation: Service	17-4-1962	ACA	NEST Ltd (GSS America Infotech Ltd)	980	5.40
Mr. Aneesh Mittal Whole Time Director S/o. Naveen Chandra Mittal B-402, South End, United Avenue, Ameerpet, Hyderabad-16 Occupation: Business	05-05-1962	B.Com	Softprojex (India) Ltd	—	10.08



Name, Fathers Name, Designation and Address	Date of Birth	Qualification	Other Directorship	Shares Held	Remuneration* (Rs. Lakhs) (2004-05)
Mr. PramodKumar Jain Whole Time Director S/o. Ramesh Chandra Jain 36, Vahini Nagar, Sikh Village, Secunderabad -11 Occupation: Service	21-06-1966	Telecom Engineering graduate	None	--	25.32
Mr. Wolfgang Werner Knop Independent Director S/o. Arno Knop Coming Cable Systems, D-58091, Profilstrasse 4, Hagen, Germany Occupation: Consultant	17-02-1944	Chemical Engineer	None	--	--
Mr. Rajiv Garg Independent Director S/o. (Late) Dr. Om Prakash Garg 403, Sibylee, Worli, Mumbai, Maharashtra - 400018 Occupation: Service	27-06-1955	25 years of experience in finance/ general management.	1) Shalimar Paints Ltd - Director 2) ETC Networks Ltd - Managing Director 3) Aplab Limited - Director	--	--
Mr. Ashok Kumar Goyal Independent Director S/o. C.L. Goyal C-19, Sector-33, Noida (U.P), India -201301 Occupation: Business	22-06-1957	FCA,ICWA, FCS & MBA	Global Advisors Ltd	--	--
Mrs. Ritulal Kumar Independent Director W/o. Dinesh Kumar Plot No.1, Lalita Nagar, Wellington Road, Westmarredpally, Secunderabad Occupation: Business	08-11-1965	Graduate	Softprojex(India) Ltd	--	6.58

*Non Executive Directors are entitled only the sitting fee. No commission/remuneration is payable to them.

BRIEF PROFILE OF DIRECTORS:

Dr R Srinivasan, aged 75 years is a Doctorate in Banking and Finance - comes with good managerial expertise. He has held several Senior Managerial Positions in the Public Sector Banks like Chairman and Managing Director of Bank of India and Allahabad Bank for several years. He is also associated currently as Chairman/Director of several companies focussing in Software, Pharma, Gems & Jewellery, Tea, Paint in addition to Mutual Fund Industry.

Mr Dinesh Kumar, aged 43 years is the Managing Director of the Company and by qualification is B.Com. Graduate. He has been associated with the Telecom Industry for the past 15 years. Mr. Dinesh Kumar joined the Company during the year 1987 as a Management Executive and since then serving the Company. He has been instrumental for the growth of the Company and has been taking care of production, technical and administration of the affairs of the Company. He has in-depth knowledge of various telecom products.



Mr K Vasudeva Rao aged 44 years is the Executive Director and is a B.Sc, F.C.A with about 20 years of experience in the Corporate Management. He has held several positions like Executive Director and CEO in Goldstone Technologies Ltd, Executive Director in Goldstone Teleservices Ltd, and several Board positions including few unlisted entities in other countries like Japan and Sri Lanka. He has varied industry exposure like Engineering (Kirloskar Electric), Tea, Telecom and Software. He has been in Telecom Industry for over 13 years focussing Operations and software for over 6 years.

Mr Aneesh Mittal, aged 44 years is the Wholetime Director of the company and by qualification is a B.com Graduate. He has over 15 years of experience in the field of General Management. He is rendering valuable services from the inception of the Company in production and assembly of cable jointing kits and other telecom products.

Mr Pramod Kumar Jain, aged 40 years is the Wholetime Director of the company and is a Telecom Engineering Graduate. He is having 15 years of experience in the Telecom Industry. He has diversified exposure to various telecom technologies such as optical transmission, data networking, operation support systems, wireless and mobile communication systems, etc. He has held important positions with Companies like Lucent Technologies Pty. Ltd., Singapore, Reliance Telecom Ltd., National Telecom Ltd. and Optel Telecommunications Ltd. in wireless telecommunication.

Mr Wolfgang Knop, aged 62 years is an Independent Director and is a Chemical Engineer from Berlin University and joined Siemens group in 1976 in cable business. After serving many years in Siemens he was posted as a Director of Sales in the Siemens subsidiary RXS Kabelgarnituren GmbH & Co., KG in the year 1990. He as Director of Sales was credited with establishing of RXS brand of products in various countries world wide including India, Japan, Korea and many other countries in Africa. On retirement as Director-Sales of RXS, he was then promoted as Managing Director in RXS in 1995. As the Managing Director he successfully grew the RXS and RXS become leader in cable accessories. In 1999-2002, he was instrumental in smooth merger of RXS with Corning Cable Systems and continued to be the Managing Director located in Hagen till 2001. In March, 2001, he joined Head quarters of Corning Cable Systems in Munich as a Director on the Board and has been serving since then.

Mr Rajiv Garg aged 43 years is Independent Director and has 25 years of experience in finance/general management. Mr. Rajiv Garg is an Engineer from Delhi. After passing Engineering in 1979, he joined State Bank of India and he has worked worked with various Corporate Capital Venture Fund, Jindal Group, Raymonds, etc. Presently he is working as a Corporate Chief Executive Office in ZEE Telefilms Limited

Mr Ashok Goyal, aged about 48 years, is an Independent Director and is professional Chartered Accountant. He has more than 25 years of experience in managing businesses especially in financial, regulatory issues and more specifically Telecom and Office Automation sectors. He is founder Chairman of Global Advisors Ltd., and was a Partner & Director of Grant Thornton India. He was involved as Executive Director in setting up the first Cellular Network in India for Modi Telestra Ltd.

Mrs Ritulal Kumar, aged 38 years is a Graduate by qualification. Smt. Ritu Lal Kumar has been associated with the Company since its inception and with her experience in finance and accounts has been instrumental in computerising the accounts and finance. Earlier she was on the Board and resigned on 25th July, 2002. To benefit from her experience, again she has been inducted as an Additional Director in the Board Meeting held on 21st September, 2002.

Borrowings Powers

Vide a resolution passed at the 18th Annual General Meeting of the Company held on 25th September, 2004 consent of the members of the Company was accorded to the Board of Directors of the company pursuant to Section 293(1) (d) of the Companies Act, 1956 for borrowing from time to time the sum of monies which together with the monies already borrowed by the Company for an amount not exceeding Rs. 60,000 Lakhs.

Appointment and Remuneration of Directors

Mr. Dinesh Kumar – Managing Director

The Board of Directors of the Company in their meeting held on 15th December, 1998 appointed Mr. Dinesh Kumar as an Additional Director. In the Board Meeting held on 22nd April, 1999, Mr. Dinesh Kumar was appointed as a Deputy Managing Director for a period of 5 years with effect from 22nd April, 1999 on a remuneration of Rs.40,000/- per month and HRA of Rs.10,000/- per month to be reviewed and revised by the Board of Directors on a yearly basis. Subsequently Mr. Dinesh Kumar has been appointed as the Managing Director in the Board Meeting held on 9th October, 2000 for a period 5 years with effect from 9th October, 2000 on remuneration of Rs. 40,000/- per month and HRA of Rs. 10,000/- per month to be reviewed and revised by the Board of Directors on a yearly basis. Members of the Company in the 17th Annual General Meeting held on 27th October, 2003 resolved to increase the remuneration of Mr. Dinesh Kumar from Rs. 50,000/- to a consolidated salary of Rs. 2,50,000/- per month with effect from 1st October, 2003. Again Mr. Dinesh Kumar has been re-appointed as the Managing Director of the Company by the members in the Extra-ordinary General Meeting held on 7th May, 2004 for a period of 3 years with effect from 1st June, 2004 at a remuneration of Rs. 12,50,000/- per month and obtained the Central Government Approval. The resolution passed by the members in this regard is reproduced below:



“RESOLVED THAT in supersession of the earlier resolution passed by the Board of Directors and the Members of the Company, and pursuant to the provisions of Sections 269 read with Schedule XIII and other applicable provisions, if any, of the Companies Act, 1956 including any statutory modification or re-enactment thereof for the time being in force, and subject to the prior approval of the Central Government, consent of the Company be and is hereby accorded for the re-appointment of Mr. Dinesh Kumar as the Managing Director of the Company for a period of three years with effect from 1st June, 2004 on the following terms and conditions:

PERIOD: Three (3) years

SALARY: Rs.8,00,000/-(Rupees Eight Lakhs only) per month

PERQUISITES:

CATEGORY – A

Following perquisites given in Category A will be allowed in addition to the salary, restricted to an amount of Rs 54,00,000/- (Rupees Fifty Four Lakh only) per annum.

(i) House Rent Allowance:

Maximum of Rs. 1,00,000/- (Rupees One Lakh only) per month

(ii) Medical Re-imburement:

Reimbursement of Medical expenses incurred by the Managing Director for self and his family members at a ceiling of one month's salary in a year or three months salary over a period of three years.

(iii) Leave Travel Concession:

For self and family once in a year incurred in accordance with any rules specified by the Company

(iv) Club Fees:

Club fees shall be reimbursable subject to a maximum of two clubs. However, this will not include admission and life membership fees.

(v) Personal Accident Insurance:

Premium not exceeding Rs. 3,000/- (Rupees three thousand per annum)

(vi) Any other perquisites or allowances for self and family as per the policies of the Company subject to a maximum of Rs. 2,75,000/- per month.

The following perquisites referred to in the Category B and C shall not be considered and included for computation of the ceiling on perquisites.

CATEGORY – B

(a). Contribution to Provident Fund, Superannuation Fund or Annuity Fund will be as per the rules of the Company. The same will be included in the computation of the ceiling on perquisites to the extent these either singly or put together are not taxable under the Income Tax Act, 1962.

(b). The Managing Director shall be entitled to Gratuity at half a month's salary for each completed year of service.

(c). Earned leave on full pay and allowance as per rules of the Company but not exceeding one (1) month leave for every eleven (11) months. Encashment of leave at the end of tenure will not be included in the computation of the ceiling on perquisites.

CATEGORY-C

(a). Free use of Company's car with driver for Company's business.

(b). Free telephone facility at residence but personal long distance calls will be billed to the Managing Director

(c). Managing Director shall not be eligible for any sitting fee for attending any meeting of the Board / Committee meeting.

RESOLVED FURTHER THAT the above remuneration shall be allowed and paid as a minimum remuneration to the Mr. Dinesh Kumar during the tenure of his appointment notwithstanding the loss or inadequacy of profits during any Financial Year during his tenure of office.

RESOLVED FURTHER THAT Board of Directors be and are hereby authorised to take such steps and do all such acts, deeds, matters and things as may be considered necessary, proper and expedient to give effect to this resolution.”



Mr. K. Vasudeva Rao - Executive Director

The Members of the Company at the Extra-ordinary General Meeting held on 28th February, 2005 have appointed Mr. K. Vasudeva Rao as a Wholetime Director of the Company with a designation of "Executive Director" at a consolidated remuneration of Rs. 2,50,000/- per month with effect from 1st March, 2005. The details of his appointment are as follows:

"RESOLVED THAT pursuant to the provisions of Sections 257 of the Companies Act, 1956 consent of the Company be and is hereby accorded to the appointment of Mr. K. Vasudeva Rao as a Director of the Company with immediate effect and whose office is liable to retire by rotation.

RESOLVED FURTHER THAT pursuant to the provisions of Sections 198, 269, 309 read with Schedule XIII and other applicable provisions, if any, of the Companies Act, 1956 Mr. K. Vasudeva Rao be and is hereby appointed as a Wholetime Director of the Company with immediate effect and who shall be entitled to receive a consolidated remuneration of Rs. 2,50,000/- per month with effect from 1st March, 2005.

RESOLVED FURTHER THAT the above mentioned remuneration shall be paid and allowed as a minimum remuneration during the currency of his tenure of office as the Whole time Director, notwithstanding the absence or inadequacy of profits in any accounting year as long as the minimum remuneration is within the prescribed limits under Section II of Part II of Schedule XIII of the Companies Act, 1956".

Mr. Aneesh Mittal - Wholetime Director

The Board of Directors in their meeting held on 15-12-1998 appointed Mr. Aneesh Mittal as an Additional Director.

The member of the Company regularised him as a Director u/s. 257 on 22-08-2001. Subsequently Mr. Aneesh Mittal was appointed as a Whole Time Director in the Annual General Meeting held on 26-10-2002 for a period of five years. The details of his appointment are:

"RESOLVED THAT pursuant to sections 198, 269, 309, 310 and schedule XIII and other applicable provisions of the Companies Act, 1956, consent of the members be and is hereby accorded for the reappointment of Shri. Aneesh Mittal as a Whole Time Director of the Company for a period of Five (5) years with effect from 26th October, 2002 on the monthly remuneration which was considered and approved by the Remuneration Committee of the Company held on 21-09-2002.

- Salary : Rs. 32,000/- per month
- House Rent Allowance : Rs. 5,500/- per month
- DA/Conveyance : Rs. 8,00/- per month

"RESOLVED FURTHER THAT the above mentioned remuneration shall be paid and allowed as a minimum remuneration during his currency of his tenure of office, notwithstanding the absence or inadequacy of profits in any Accounting year as long as the minimum remuneration is within the prescribed limits under Section II of part XIII of the Companies Act, 1956".

Mr. Pramod Kumar Jain – Wholetime Director

The Board of Directors of the Company in their meeting on 21st September, 2002 appointed Mr. Pramod Kumar Jain as an Additional Director. The Members of the Company have appointed him as a regular Director u/s. 257 as well as appointed him as a Wholetime Director in the 16th Annual General Meeting held on 26th October, 2002 for a period of 3 years with effect from 26th October, 2002 on a Consolidated Remuneration of Rs. 1,50,000/- per month. Details of appointment are as follows:

"RESOLVED THAT pursuant to Sections 198, 269, 309, 310 and Schedule XIII and other applicable provisions, if any, of the Companies Act, 1956 and consent of the members be and is hereby given for the appointment of Mr. Pramod Kumar Jain as a Whole-time Director for a period of three (3) years on a Consolidated Remuneration of Rs. 1,50,000/- (Rupees One lakh and fifty thousand only) per month with effect from 26th October, 2002.

RESOLVED FURTHER THAT the above mentioned remuneration shall be paid and allowed as minimum remuneration during the currency of his tenure of office, notwithstanding the absence or inadequacy of profits in any accounting year as long as the minimum remuneration is within the prescribed limits under Section II of Part II of Schedule XIII of the Companies Act, 1956".

The Members of the Company at the Extra-ordinary General Meeting held on 25th November, 2003 have resolved to increase the remuneration from Rs. 1,50,000/- to Rs. 2,03,500/- with effect from 1st October, 2003. Again the members in the Extra-ordinary General Meeting held on 31st January, 2005 have resolved to pay remuneration to Mr. Pramod Kumar Jain as enumerated below with effect from 1st January, 2005



Details of the resolution is as follows:

“RESOLVED THAT pursuant to the provisions of Section 198, 269, 309, 310 read with Schedule XIII to the Companies Act, 1956, the consent of the Company be and is hereby accorded for the revision in the remuneration of Shri. Pramod Kumar Jain, Wholetime Director from the existing salary of Rs.2,03,500/- per month to a consolidated salary of Rs. 2,18,500/- per month with effect from 1st January, 2005.

RESOLVED FURTHER THAT the above mentioned remuneration shall be paid and allowed as a minimum remuneration during the currency of tenure of his office as the Whole-time Director, notwithstanding the absence or inadequacy of profits in any accounting year as long as the minimum remuneration is within the prescribed limits under Section II of Part II of Schedule XIII of the Companies Act, 1956”.

The Members of the Company at the Extra-ordinary General Meeting held on 25th October, 2005 have again re-appointed as a Wholetime Director with the then existing remuneration of Rs. 2,18,500/- per month for a further period of three years w.e.f. 26th October, 2006. Details of the resolution is as follows:

“RESOLVED THAT in super session of the earlier resolution passed in this regards and pursuant to the provisions of Section 198, 269, 309, 310 read with Schedule XIII to the Companies Act, 1956, the consent of the Company be and is hereby accorded for the re-appointment of Shri. Pramod Kumar Jain as Whole-time Director of the Company for a period of Three (3) years on a consolidated remuneration of Rs. 2,18,500/- per month with effect from 26th October, 2005 , which was considered and approved by the Remuneration Committee of the Company.

RESOLVED FURTHER THAT the above mentioned remuneration shall be paid and allowed as a minimum remuneration during the currency of tenure of his office as the Whole-time Director, notwithstanding the absence or inadequacy of profits in any accounting year as long as the minimum remuneration is within the prescribed limits under Section II of Part II of Schedule XIII of the Companies Act, 1956”.

CORPORATE GOVERNANCE

The provisions of the listing agreement to be entered into with the Stock Exchange with respect of the Corporate Governance will be applicable to the Company immediately upon the listing of our Equity Shares on the Stock Exchange (s). XL intends to comply with such provisions, including with respect to the appointment of Independent Directors in the Board and the constitution of the following Board Committees - The Audit Committee, the Remuneration Committee, and the Investor Grievance Committee. XL undertakes to adopt the Corporate Governance Code as per Clause 49 of the Listing Agreement to be entered into with the Stock Exchanges prior to the Listing.

The Company has complied with SEBI guidelines in respect of Corporate Governance especially with respect to the Board composition, constituting of Committees.

Composition of the Board of Directors

The Composition of the Board of the Directors, as on date, is given below:

Sr. No.	Name	Representing as	Type of Directorship
1.	Dr. R. Srinivasn	Non-executive Chairman	Independent Chairman
2.	Mr. Dinesh Kumar	Managing Director	Executive & Promoter Director
3.	Mr. K. Vasudeva Rao	Executive Director	Executive & Professional Director
4.	Mr. Aneesh Mittal	Wholetime Director	Executive & Promoter Director
5.	Mr. Pramod Kumar Jain	Wholetime Director	Executive & Professional Director
6.	Mr. Wolfgang Werner Knop	Director	Non- Executive & Independent Director
7.	Mr. Rajiv Garg	Director	Non- Executive & Independent Director
8.	Mr. Ashok Kumar Goyal	Director	Non-Executive & Independent Director
9.	Smt. Ritulal Kumar	Director	Non-Executive & Director

The Company has already constituted the following committees and framed their terms of reference.



Audit Committee

The Audit Committee has been constituted on 01.03.2006. The Committee currently consists of four directors namely Dr R Srinivasn, (Chairman of the Committee), Mr. Rajiv Garg, Mr. Ashok Kumar Goyal and Mr. K Vasudeva Rao. Except Mr. K. Vasudeva Rao all these directors are independent directors with Mr. Ashok Kumar Goyal having finance and accounting background.

The terms of the Audit Committee is to comply with the requirements of section 292A of the Companies Act and Clause 49 of the listing agreement to be entered into with the Stock Exchange (s). The scope of Audit Committee shall include but shall not be restricted to the following:

1. Authority to investigate any matter pertaining to the items specified in section 292A of the Companies Act or referred to it by the Board
2. Investigate any activity within its terms of reference
3. Oversight of the Company's financial reporting process and the disclosure of its financial information to ensure that the financial statement is correct, sufficient and credible
4. Reviewing with management the annual financial statements
5. Reviewing with the management, external and internal auditors, and the adequacy of internal control systems.
6. Reviewing the adequacy of internal audit function, including the structure of the internal audit department, staffing and seniority of the official heading the department, reporting structure coverage and frequency of internal audit
7. Reviewing the Company's financial and risk management policies
8. Periodic discussion with the auditors about internal control systems, scope of audit including the observations of the auditors and review the quarterly, half-yearly, and annual financial statements before submissions to the Board.

Shareholders / Investor Grievance and Share Transfer Committee

The Shareholder / Investor Grievance Committee have been reconstituted on 01-03-2006. The Committee currently consists of three directors,

1. Mr. Rajiv Garg (Chairman of the Committee)
2. Mr. Dinesh Kumar
3. Mr. K Vasudeva Rao and

The Committee has been formed to specifically look into all the works relating to shares and shareholders grievance, i.e., approval of transfer/transmission/demat/remat of shares, issue of duplicate, split-up, consolidation, renewal of share certificate, non receipt of balance sheet, non receipt of declared dividends etc.

Remuneration Committee

The Remuneration Committee has been reconstituted on 01-03-2006. The Committee currently consists of three directors,

1. Dr R Srinivasan, Chairman
2. Mr. Rajiv Garg, Director
3. Mr. Ashok Kumar Goyal
4. Mr. Wolfgang Werner Knop

All the directors of this committee are independent directors. The members shall elect the chairman of the Committee from amongst themselves. The Committee has been formed to decide and approve the terms and conditions for appointment of executive directors of the Company and remuneration payable to other directors and executives of the Company and other matters related thereto.



SHAREHOLDING OF DIRECTORS

As per Company's Articles, Directors of the Company are not required to hold any Equity Shares in the Company. Save and except as below, Directors do not hold any Equity Shares in the Company as on the date of filing of this Red Herring Prospectus.

Sr. No.	Names of our Directors	No. of Equity Shares
1.	Mr. Dinesh Kumar, Managing Director	14,91,290
2.	Mr. K Vasudeva Rao, Executive Director	980

Interest of Directors

Except as stated in "Related Party Transactions" on page 90 of the Red Herring Prospectus, and to the extent of shareholding in the Company, the directors do not have any other interest in the business. The directors are interested to the extent of shares allotted to them.

All the Directors may be deemed to be interested to the extent of the sitting fees and other remuneration for the services rendered and the reimbursement of expenses, if any, payable to them under the Articles. The Directors may also be deemed to be interested to the extent of:

1. The shares, if any, held by them or by the relatives or by firms or companies of which any of them is a Partner and a Director / Member respectively.
2. The shares, if any, out of the present issue that may be subscribed for and allotted to them or their relatives or any company in which they are Directors / Members of to firms in which they are Partners.

Transactions with entities in which Directors are interested have been disclosed as Related Party Transactions in the Auditor's Report.

The Managing Director is interested to the extent of the remuneration paid to him for services rendered to the Company. Further the Managing Director is interested to the extent of equity shares held by him and also to the extent of any dividends payable to him and other distributions in respect of the said Equity Shares.

The Whole Time Directors are interested to the extent of the remuneration paid to them for services rendered to the Company. Further they are interested to the extent of equity shares held by them and also to the extent of any dividends payable to them and other distributions in respect of the said Equity Shares.

The Company has not entered into any contracts, agreements or arrangement in which the Directors are interested directly or indirectly and no payments have been made to them in respect of these contracts, agreements or arrangement or are proposed to be made.

Payment of Benefit to Promoters and Officers of the Company:

No amount or benefit has been paid or given to the Company's Promoters or Officers since the incorporation of the Company nor is intended to be paid or given to any Promoter or any Officer of the Company except their normal remuneration and /or reimbursement for services as Directors, Officers or Employees of the Company or otherwise in accordance with law.

Changes in Board of Directors during Last Three Years

Name	Date of Appointment	Date of Resignation	Reason	Remarks
Mr. Dinesh Kumar	15-12-1998	---	---	<ul style="list-style-type: none">• Originally appointed as an Additional Director and later elevated as the Deputy Managing Director on 22-04-1999.• Further he has been elevated as the Managing Director w.e.f. 09-10-2000.• Again re-appointed for 3 year w.e.f. 01-06-2004
Mr. Rajiv Garg	20-10-1990	---	---	---
Mr. T. Muralidharan	21-09-2002	---	---	Being an Additional Director, his appointment regularized in Annual General Meeting held on 26-10-2002



Name	Date of Appointment	Date of Resignation	Reason	Remarks
T. Muralidharana	—	01-03-2006	—	Resigned from the Board
Mr. Wolfgang Knop	23-10-1997	—	—	Being an Additional Director, his appointment regularised in Annual General Meeting held on 15-12-1997
Smt. Renu Mittal	29-08-1991	10-07-2002	Personal	—
Smt. Renu Mittal	21-09-2002	01-02-2006	Personal	Being an Additional Director, his appointment regularized in Annual General Meeting held on 26-10-2002
Mr. Rajiv Kumar Jain	10-7-2002	07-02-2004	Personal	Being an Additional Director, his appointment regularized in Annual General Meeting held on 26-10-2002 and appointed as an Executive Director
Smt. Seema Jain	15-12-1997	10-07-2002	Personal	Being an Additional Director , his appointment regularized in Annual General Meeting held on 22-08-2001
Smt. Seema Jain	21-09-2002	01-02-2006	Personal	Being an Additional Director, appointment regularised in the AGM held on 26-10-2002
Smt. Ritulal Kumar	29-08-1991	10-07-2002	Personal	—
Smt. Ritulal Kumar	21-09-2002	—	—	Being an Additional Director, appointment regularised in the AGM held on 26-10-2002
Mr. Pramod Kumar Jain	21-09-2002	—	—	<ul style="list-style-type: none"> Being an Additional Director, appointment regularised in the AGM held on 26-10-2002 Appointed as a Whole time Director in AGM held on 26-10-2002 for 3 years
Mr. Pramod Kumar Jain	25-10-2005	—	—	Again reappointed in EGM held on 25-10-2005 for the period of 3 years.
Mr. K. Vasudeva Rao	28-02-2005	—	—	Appointed as a Director as well as a Whole time Director with a designation of an “Executive Director” in EGM held on 28-02-2005
Mr. Aneesh Mittal	15-12-1998	—	—	<ul style="list-style-type: none"> Being an Additional Director, regularised in AGM held on 22-08-2001 Appointed as a Wholetime Director for 5 years in AGM held on 26-10-2002
Dr. R. Srinivasan	01-03-2006	—	—	Appointed as Non Executive Chairman in the Board Meeting held on 01-03-2006
Mr. Ashok Kumar Goyal	01-03-2006	—	—	Co-opted as Additional Director in the Board Meeting held on 01-03-2006



ORGANIZATION STRUCTURE

XL ORGANIZATION CHART

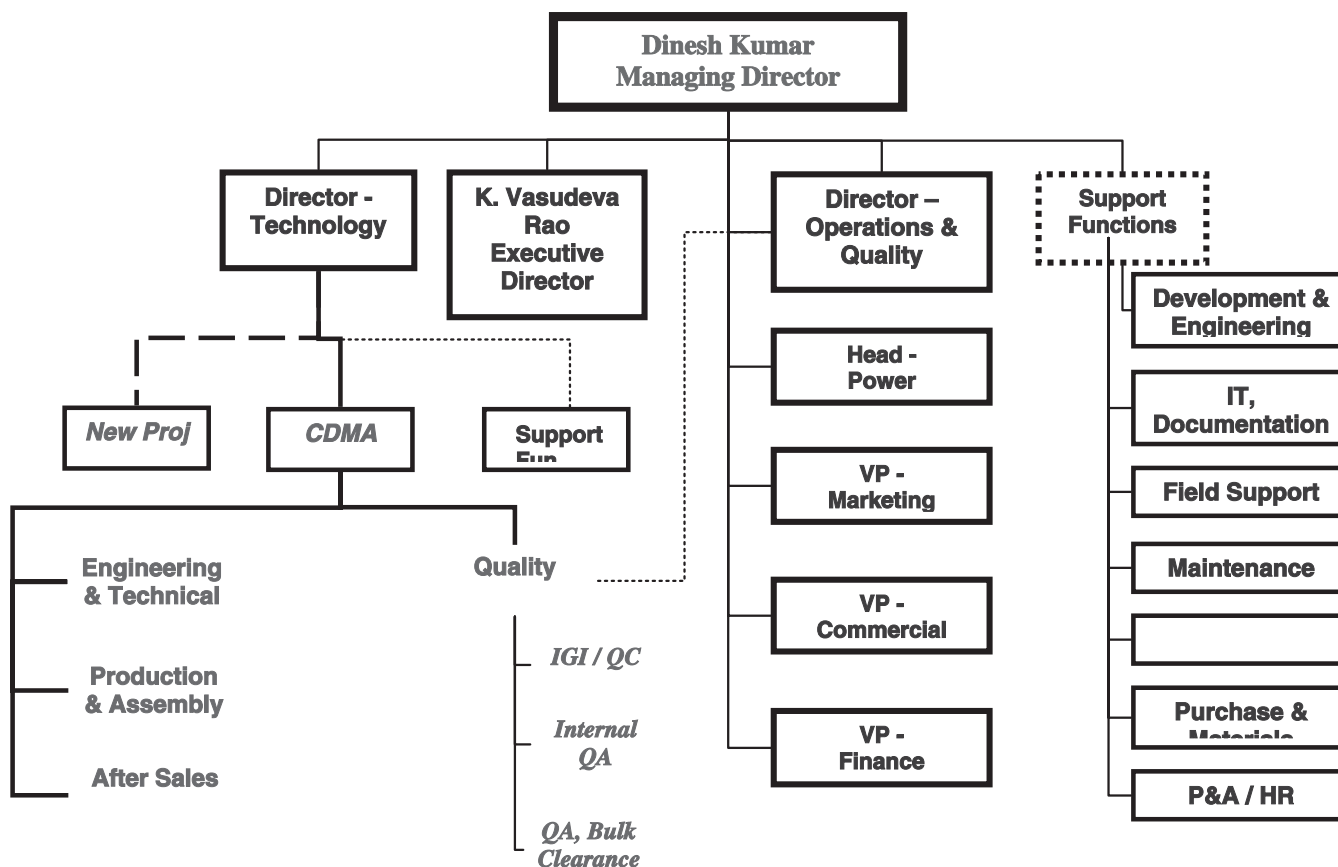

Key Managerial Personnel

XL employs personnel in various capacities. The Company's management team is made up of qualified professionals with experience in management in their respective fields of expertise. The Managing Director and Executive Director are assisted in their day-to-day responsibilities by a team of Key Managerial Personnel as under:

Name	Designation	Date of Birth	Qualification	Work Exp. (Years)	Area of Specialization	Gross Remuneration Per Month
Mr. V.V Rao	SVP – Finance & Corporate	06.09.1959	M.Com	20	Finance & Accounts	Rs.1,01,285
Mr Prasanna Gargav	VP- Marketing – Delhi Region	16.03.1967	BTech, MBA	15	Marketing	Rs.75,000
Mr Nanchariah	VP –Unit Head – Power Electronics	28.2.1962	B Tech	20	Manufacturing Electronic Products	Rs.72,160
Mr Bheem Reddy	GM – Purchase	18.11.1952	B Tech	20	Procurement	Rs.34,097
Mr Manoj	Unit Head – CDMA	16.03.1966	B Tech	15	Manufacturing	Rs.72,482



V V Rao – Sr Vice President Corporate and Finance – Has over 20 years of experience in handling Finance & Accounts. He has been working with XL for over 5 years. He has worked with several companies before joining XL.

N Nanchariah – Vice President (Power Electronics) – He has been working XL for over 4 years as Unit Head – SMPS Manufacturing. He is a qualified engineer and has over 20 years of Experience including companies like SABNIFE Ltd.

Prasanna Gargav – Vice President (Marketing) – He has over 15 years of experience in various filed and has joined XL in the year 2005. He served reputed organizations like CII as Regional Director for MP and Telecom Majors like Bharti Tele Ventures Ltd. He is a qualified Engineer.

P Bheem Reddy – General Manager (Purchase) – He is qualified engineer and has experience over 20 years in the Purchase Department. He has been in XL for over 10 years as Head of Purchase Department.

Manoj K Palod – Dy General Manager (CDMA – Unit Head) – Manoj has over 15 years of experience in Telecom Field and has worked with Industry Leaders like Hughes Telecom for over 10 years. He is a qualified Engineer and has been working with XL for over 3 years.

Prashant P Joshi – Dy General Manager (CDMA – Technical) – Prashant is a qualified engineer with over 14 years of experience in Telecom Technologies. He has been working with XL for over 3 years.

The persons whose names appear as key management personnel are on the pay roll of the Company as permanent employees.

There is no arrangement or understanding with major shareholders, customers, suppliers or others pursuant to which any person was selected as director or member of senior management. None of the key managerial personnel have any relationship with the promoters or directors of the company.

Shareholding of Key Managerial Personnel

Other than the Directors, no other Key Managerial Person holds any shares in the company as on the date of filing the RHP.

Bonus or Profit Sharing Plan of the Key Managerial Personnel

There is no fixed or certain bonus or profit sharing plan for the key managerial personnel. However, sometimes, the Company makes ex-gratia payments to its employees on the basis of their performance.

Changes in Key Managerial Personnel During the Last 3 Years

Except for the following, there has been no change in the Key Managerial Personnel of our Company within three year prior to the date of filing Red Herring Prospectus with SEBI:

Name	Designation	Date of Joining	Date of Cessation	Reason
P A Paul	General Manager (Marketing)	28.2.2005	23.08.2006	Resigned
A Pampapathy	Vice President (Marketing)	08.07.2002	31.05.2006	Resigned
Prasanna Gargav	Vice President (Marketing)	13.1.2005	–	Joined

Loans to Key Managerial Personnel

There are no loans outstanding against key managerial personnel as on 31.3.2006

Employees

The total manpower directly employed by the Company is 275 as on 31-03-2006 including site staffs. For entire labour requirement, the Company banks mainly on its labour contractors.

Employees Stock Option Scheme

The Company does not have any Employees Stock Option Scheme as on date.

Payment or Benefit to Officers of the Company

Except the payment of salaries and perquisites, the Company makes ex-gratia payments to its officers as and when it deems fit.



OUR PROMOTERS

Promoter - Individuals

Mr Dinesh Kumar

Designation: Managing Director

	Permanent Account Number	AHFPK1339L
	Passport Number	Z1253064
	Voter ID Number	—
	Driving License Number	DLRAP0447112003
	Address:	1, Lalitha Nagar, Wellington Road, Westmarredpally, Secunderabad

Mr Dinesh Kumar, aged 43 years is the Managing Director of the Company and by qualification is B.Com. Graduate. He has been associated with the Telecom Industry for the past 15 years. Mr. Dinesh Kumar joined the Company during the year 1987 as a Management Executive and since then serving the Company. He has been instrumental for the growth of the Company and has been taking care of production, technical and administration of the affairs of the Company. He has in-depth knowledge of various telecom products.

Mr Dinesh has been appointed as Managing Director in Oct 2000. The Company has seen good growth since then and his performance in 6 years period is reflected as under:

Year	Sales (Rs.)	Growth %	Profit (Rs.)	Growth%
1999-2000	3247 Lakh		35.27 Lakh	
2005-2006	39541 Lakh	1218%	1381.72 Lakh	3917%

He was also responsible in bringing the new Business Initiatives like entering in to Mobile Market Segment with Global Technology Partnerships, entering into SMPS market and also the Ethanol initiative. These initiatives have been proved successful which resulted in the growth of revenues from Rs.3247 Lakh in 1999-2000 to Rs.39541 Lakh. Further he has brought in the professionalism at all levels including the Board Appointments during this period resulting two professional working directors.

Promoters – Trust - Snehlata Lal Family Welfare Trust

The Trust has been formed by deed indenture dated 23rd October 1993 and registered on 8th November 1993. The Trust been formed by Late Mr Sunder Lal and it is intended to ensure by giving equal shares to all five daughters and families more specifically his grand children. Trust Corpus has been initially formed by transferring Rs.5000 in cash and later by transferring the estate of Late Mr Sunder Lal and Mrs Snehlata Lal.

Current List of Beneficiaries:

- Children of Smt Seema Jain and Mr Naveen Jain
 - Mrs Nupur Jain 10%
 - Master Siddarth Jain 10%
- Children of Mrs Renu Mittal and Mr Aneesh Mittal
 - Master Askhay Mittal 10%
 - Master Viplav Mittal 10%
- Children of Mrs Ritu Lal Kumar and Mr Dinesh Kumar
 - Master Sheshank Kumar 10%
 - Master Sharukh Kumar 10%
- Children of Smt. Reena Graham and Mr Benjamin Graham
 - Miss Kutira 10%
 - Miss Kendra 10%



5. Children of Smt Shikha Lal and Mr Terry Jenson

a. Master Taariq Lal Jenson

20%

Of the above 9 beneficiaries, following have attained the age of majority:

1. Mrs. Nupur Jain
2. Mr. Siddarth Jain
3. Mr. Akshay Mittal

These beneficiaries have authorised the Managing Trustee to manage the day to day affairs of the Trust and have not opted to be part of the Trustees. Hence, the Trustees remain the same despite beneficiaries becoming major till the validity of the Trust i.e. 2013. The continuance of Trust after 2013 is not known and will be decided in future.

Mr Dinesh Kumar, is the promoter of the Company and also the Managing Trustee of the Trust. His Children has 20% beneficial interest in the Trust. Further the remaining beneficiaries of the Trust are children of his co-brothers and hence he is uncle of the remaining beneficiaries.

Registered Office : A 1/3, Chandralok Complex, S D Road, Secunderabad – 500 003

PAN: AABTS 4945D

Trust Objects include Business and Investment:

Trustees shall engage in and carry on business development programmes and any other development programmes with the corpus sum through investment, business, or any other commercial activity and to carry on any activity for and on account of the trust established by this deed and may invest any part of the fund or assets of the trust fund in such activity in the name of the trust.

Trustees:

- | | |
|-------------------|------------------|
| 1. Dinesh Kumar | Managing Trustee |
| 2. J Bhadra Kuma | Managing Trustee |
| 3. Aneesh Mittal | Trustee |
| 4. Seema Jain | Trustee |
| 5. Ritu Lal Kumar | Trustee |

Voting Rights:

Trustees have the absolute power to decide on the voting issue, where the Trust has investment and has to vote and nominate accordingly the Trustees.

Snehlata Lal Family Welfare Trust

Rs in Lakh

Balance Sheet as at	31.3.2005	31.3.2004	31.3.2003
	Audited	Audited	Audited
Corpus	0.64	8.18	18.56
Unsecured Loans	43.42	35.86	36.38
Current Liabilities	0.05	0.05	0.05
Total	44.11	44.11	54.98
Investments @ cost			
a. XL Telecom Ltd.	31.84	31.84	31.84
b. Lakshmi Telecom	11.72	11.72	22.53
Cash & bank balances	0.55	0.55	0.61
Total	44.11	44.11	54.98



Duration of the Trust

The Trust was initially formed on 23rd of October 1993 and as per clause 4 of the Trust deed executed, Period of the Trust is for a period of 12 years from its formation. However, the said clause has been amended vide Amended Deed executed on 6th October 2000 by extending the Period of the Trust to 20 years. Hence the Period of the Trust expires by 23rd October 2013.

Investments:

As per clause 7 of the original Trust Deed, Trustees are free to Invest all monies for the Benefit of Trust. Further the first amended Trust Deed dated 20th May 1997 empowers the Trustees to mortgage/hypothecate/create charge upon or otherwise encumber the properties of the trust for the business of trust.

The Trustees have passed a resolution in their meeting held on 3rd May 2006 offering the shares held by them for Lock-in, as required by the Law and authorized the Managing Trustee to sign and submit the same to the relevant authorities.

Declaration

Company confirms that the Permanent Account Number, Passport number and Bank Account Number of Mr. Dinesh Kumar and Snehalata Lal Family Welfare Trust are being submitted to the Stock Exchanges on which Equity Shares are proposed to be listed at the time of filing Draft Red Herring Prospectus with them.

The details of the litigation, disputes towards tax liabilities or criminal / civil prosecution / complaint against the above mentioned promoters have been disclosed in the section titled "Outstanding Litigations and Material Developments" on page 111.

Common Pursuits

There is no company in the Group, which is engaged in the same business as that of the Company.

Promoter Group Companies

The details of the promoter group companies are as follows.

Company Name	Softprojex (India) Limited
PAN	AAFCS0500D
Registration	01-23059
Nature of Business	Information Technology
Background	Software Company
Owned	100% ownership with M/s.Snehalata Lal Family Welfare Trust

PROMOTER GROUP

In addition to our promoters, the following persons constitute the Promoter Group:

- Mrs. Seema Jain
- Mrs. Ritulal Kumar
- Mrs. Renu Mittal
- Sofrprojex (India) Limited

Interest of Promoters

Promoter, Mr. Dinesh Kumar may be deemed to be interested to the extent of the sitting fees and other remuneration for the services rendered and the reimbursement of expenses, if any, payable to them under the Articles. The Promoter may also be deemed to be interested to the extent of:

1. The shares, if any, held by him or by the relatives or by firms or companies of which any of them is a Partner and a Director / Member respectively.

Companies with which the Promoters have disassociated themselves in the last three years

The promoters of the company have not disassociated themselves from any company in last three years.



Transactions with entities in which Promoter is interested have been disclosed as Related Party Transactions in the Auditor's Report.

Related Party Transactions

Please refer "Related Party Transactions" as mentioned in the Auditors' Report given in this Red Herring Prospectus on page 90.

Currency of presentation

In this Red Herring Prospectus, all references to "Rupees" and "Rs." are to the legal currency of India; all references to "U.S. Dollars" and "US\$" are to the legal currency of the United States.

Any percentage amounts, as set forth in "Risk Factors", "Business", "Management's Discussion" and "Analysis of Financial Condition and Results of Operations" in this Red Herring Prospectus, unless otherwise indicated, have been calculated on the basis of Company's financial statements prepared in accordance with Indian GAAP.

Dividend Policy

The Company doesn't have any written policy for dividend payment.



SECTION V: FINANCIAL INFORMATION

AUDITORS' REPORT

To,
The Board of Directors,
XL Telecom Limited,
335, Chandralok Complex,
Secunderabad – 500 003.

- A. a) We have examined the annexed financial information of *XL Telecom Limited* for the five financial years ended June 30th, 2006 being the last date to which the accounts of the Company have been made up and audited by us.
- b) In accordance with the requirements of
1. Paragraph B (1) of Part II of Schedule II to the Companies Act, 1956;
 2. The securities and Exchange Board of India (Disclosure and Investor Protection) Guidelines, 2000 ('the SEBI Guidelines') issued by the Securities and Exchange Board of India ('SEBI') on January 19, 2000 in pursuance to Section 11 of the Securities and Exchange Board of India Act, 1992 and related amendments and
 3. Our terms of reference given vide the Company's letter dated Nov 2, 2006 requesting us to carry out work in connection with the Issue as aforesaid.

We report that the restated assets and liabilities of the Company as at June 30, 2002, 2003, 2004, 2005 and 2006 are as set out in Annexure I to this report after making such adjustments / restatements and regrouping as in our opinion are appropriate and are subject to the Significant Accounting Policies and notes to account as appearing in Annexure III.

We report that the restated profits of the Company for the financial years ended June 30, 2002, 2003, 2004, 2005 and 2006 are as set out in Annexure II to this report. These profits have been arrived at after charging all expenses including depreciation and after making such adjustments / restatements and regrouping as in our opinion are appropriate and are subject to the Significant Accounting Policies and notes to accounts as appearing in Annexure III to this report. The Company has not paid any dividend on Equity Shares in any of the years mentioned above.

- B. We have examined the following financial information relating to the Company proposed to be included in the Red Herring Prospectus, as approved by you and annexed to this report:
1. Statement of Cash Flow as appearing in Annexure IV to this report;
 2. Statement of Debtors enclosed as Annexure V to this report;
 3. Details of loans and advances as appearing in Annexure VI to this report;
 4. Statement of Secured Loans as appearing in Annexure VII to this report.
 5. Statement of Unsecured Loans as appearing in Annexure VIII to this report;
 6. Statement of Operational Income as appearing in Annexure IX to this report;
 7. Statement of Other Income as appearing in Annexure X to this report;
 8. Details of Contingent Liabilities as appearing in Annexure XI to this report;
 9. Accounting Ratios as appearing in Annexure XII to this Report;
 10. Capitalisation Statement as at June 30, 2006 as appearing in Annexure XIII to this report;
 11. Statement of Tax Shelters as appearing in Annexure XIV to this report;
- C a) In our opinion the financial information of the Company as stated in Para A and B above read with Significant Accounting Policies enclosed in Annexure III to this report, after making adjustments / restatements and regroupings as considered appropriate and subject to certain matters as stated in Notes to the Statements, has been prepared in accordance with Part II of Schedule II of the Act and the SEBI Guidelines.



- b) This report is intended solely for your information and for inclusion in the Offer Document in connection with the specific Public Offer of the Company and is not to be used, referred to or distributed for any other purpose without our prior written consent.

For **SATYANARAYANA & CO**
Chartered Accountants

J JAGANNADHA RAO
Partner
Membership No. 6239

Place : Hyderabad
Date : Nov 6th 2006



Annexure – I

Statement of Restated Assets and Liabilities

(Rs. In Lakh)

Particulars	As at June, 30				
	2002	2003	2004	2005	2006
Fixed Assets (A)					
Gross Block	1236.55	2065.41	2140.35	3003.98	3034.75
Less Depreciation	489.66	572.14	670.18	792.95	937.19
Net Block	746.89	1493.27	1470.17	2211.03	2097.56
Capital Work in Progress	585.45	0.00	604.04	0.00	0.00
Net Block (Total A)	1332.34	1493.27	2074.21	2211.03	2097.56
Investments (B)	1.94	0.00	3.17	3.17	0.00
Current assets, Loans and Advances (C)					
Inventories	841.08	836.86	614.72	1219.40	3978.51
Sundry Debtors	1587.46	3222.40	3788.63	4961.90	8888.05
Cash and Bank Balances	557.99	399.68	1020.86	834.21	1209.96
Loans and Advances	724.22	468.60	276.67	219.92	422.19
Total (C)	3710.75	4927.54	5700.88	7235.43	14498.71
Liabilities and Provisions (D)					
Secured Loans	2212.52	3591.16	3768.47	5274.96	5759.14
Unsecured Loans	0.00	0.00	0.00	0.00	0.00
Current Liabilities and Provisions	1208.90	1055.01	1767.22	1224.64	2977.25
Total (D)	3421.42	4646.17	5535.69	6499.60	8736.39
Networth (A+B+C-D) = (E)	1623.61	1774.64	2242.57	2950.03	7859.88
Represented By					
1 Share Capital	334.56	334.56	334.56	334.56	1054.32
2. Reserves	1289.05	1440.08	1908.01	2615.47	6805.56
Networth	1623.61	1774.64	2242.57	2950.03	7859.88
Less: Miscellaneous Expenses	0.00	0.00	0.00	0.00	0.00
Networth	1623.61	1774.64	2242.57	2950.03	7859.88

Note:

- The fixed assets have not been revalued during any of the period under reporting.



Annexure II

Statement of Restated Profits and Losses

(Rs. In Lakh)

	Year ended June,30				
	2002	2003	2004	2005	2006
Income					
Sales :					
Of products manufactured by the Company	4002.21	6054.96	21219.50	29607.75	39445.02
Of products traded in by the Company	881.07	319.31	174.97	83.60	84.05
Total	4883.28	6374.27	21394.47	29691.35	39529.07
Other income	37.96	50.77	36.73	52.26	66.20
	4921.24	6425.04	21431.20	29743.61	39595.27
Expenditure					
Raw Materials consumed	3417.55	4840.05	18690.57	25908.31	34795.68
Staff Costs	262.36	317.99	365.61	385.19	490.80
Other manufacturing expenses	29.57	29.10	37.58	56.93	83.07
Depreciation	58.25	82.48	99.87	128.57	154.82
Administration Expenses	252.47	289.83	445.07	626.23	805.98
Selling and Distribution Expenses	194.19	112.24	358.84	330.63	701.10
Interest	309.53	582.32	907.36	1235.29	1182.11
Total	4523.92	6254.01	20904.90	28671.15	38213.56
Net Profit before tax and extraordinary items	397.32	171.03	526.30	1072.46	1381.71
Prior Period Adjustment	19.60				
Taxation	38.64	20.00	58.37	365.00	310.00
Net Profit before deferred tax	378.28	151.03	467.93	707.46	1071.71
Add/Less deferred Tax	0.00	0.00	220.00	113.41	-9.33
Net Profit after adjusting deferred tax	378.28	151.03	247.93	594.05	1081.04

* Income Tax for the year ended 30.06.2006 includes Rs.12.75 Lakh provision towards 'Fringe Benefit Tax' Liability.

Annexure – III

Significant Accounting Policies and Notes to Accounts

(1) Significant Accounting Policies

1.1) Accrual system of accounting

The company follows the accrual system of accounting in respect of all items of expenditure and income except in case of leave encashment of employees and warranty claims and the same are accounted in the year of settlement.



1.2) Fixed Assets

Fixed Assts are stated at cost of acquisition inclusive of freight duties taxes and incidental expenses relating to acquisition installation erection and commissioning less depreciation. In case of projects related preoperative expenses form part of value of assets.

1.3) Inventories

Raw material stores spare parts and components are valued on weighted average basis at net landed cost. Work in progress is valued at Works Cost. Finished Goods are valued at Cost or Market Value whichever is lower. In all the above cases necessary adjustments are made in respect of non-moving slow moving damaged and unserviceable goods.

1.4) Depreciation

Depreciation is provided on Straight Line Method on the original value of Assets at the rates specified in Schedule XIV to the Companies Act 1956. Depreciation on Assets bought / sold during the year is charged at applicable rates on monthly basis depending upon the month of financial year in which the Asset is put to use / sold.

1.5) Revenue Recognition

The Company recognizes sales at the point of dispatch of goods to the customers.

1.6) Retirement Benefits

Gratuity and Superannuation liability as on 30.06.2004 is not determined, as Gratuity and Superannuation are accounted for on Cash Basis.

1.7) Foreign currencies

Exports and imports are accounted at exchange rate prevailing on the date of negotiation of documents where such transactions are not covered by forward contract. Gain or loss arising out of fluctuation in exchange rates is accounted on the basis of actual realisation or payment.

1.8) Contingent Liabilities

Financial effect of contingent liabilities is disclosed based on information available upto the date on which financial statements are approved. However where a reasonable estimate of financial effect cannot be made suitable disclosures are made with regard to this fact and the existence and nature of the contingent liability.

(2) Change in Accounting Policy

There is no change in accounting policy in the reporting years.

(3) Earning per Share:

	FY 2002	FY 2003	FY 2004	FY 2005	FY 2006
Face value per Share (Rs.)	10.00	10.00	10.00	10.00	10.00
(A) Weighted average number of equity shares					
1. Number of Equity Shares at the beginning of the year	3,345,596	3,345,596	3,345,596	3,345,596	3,345,596
2. Number of Equity Shares at the end of the year	3,345,596	3,345,596	3,345,596	3,345,596	10,543,192
3. Weighted average number of Equity shares outstanding during the year (On annualised basis)	3,345,596	3,345,596	3,345,596	3,345,596	6,094,594
(B) Net profit after tax available for Equity Shareholders (Rs. in Lakh)	378.38	-50.97	449.93	594.05	1067.17
(C) Basic and diluted earning per share (in Rs.)	11.31	-1.52	13.45	17.76	17.51



(4) Deferred Tax

In term of Accounting Standard on “Accounting for Taxes on Income” (AS-22) the Company has recognized deferred taxes during the year ended June 30, 2003, 2004, 2005 and 2006.

Rs in Lakh

Deferred Tax Liability / (Assets)	FY 2003	FY 2004	FY 2005	FY 2006
On account of Depreciation				
Items Disallowed under the I.T. Act	202.00	18.00	113.41	-9.33
- Provision for Leave encashment	0.00	0.00	0.00	0
- Provision for Gratuity	0.00	0.00	0.00	0
Total Deferred Tax Liability / (Assets) as on balance sheet date	202.00	18.00	113.41	-9.33
Add/Less: - Opening Balance of deferred tax Liability	0.00	202.00	220.00	333.41
Debited / (Credited) in Profit & Loss A/c	202.00	18.00	113.41	-9.33

(5) Change in the status and Name

The Company was originally incorporated as a Private Limited company under the provisions of the Companies Act, 1956 on 3rd day of October 1985 as “XL Cable Splices Private Limited” with The Registrar of Companies, Andhra Pradesh, Hyderabad and subsequently the name of the company was changed to “XL Telecom Private Limited” on 18th day of December 1985. Later, the Company was converted into a Public Limited Company by the name “XL Telecom Limited” vide fresh Certificate of Incorporation dated 31st day of December, 1990 obtained from the said Registrar of Companies.

(6) Related Party Transactions

Related Party Transactions Disclosures: The Company has entered into certain related party transactions. The related party transactions cover the financial transactions carried out in the ordinary course of business and /or discharge of contractual obligations. There are no common pursuits among the group companies and all the transactions are at Arm’s length and are subject to Transfer pricing regulations. The details of the transactions as certified by the auditors of the company are as follows. As required by Accounting Standard 18.

FY 2005-06

(a) Names of related parties and nature of relationship

Category of related parties	Names
Holding Companies	nil
Subsidiaries of the Company	nil
Associates	
• Company	Softprojex (India) Ltd
• Trust	Snehalathalal Family Welfare Trust
Key Management Personnel and their relatives	
- Executive Directors	Dinesh Kumar Aneesh Mittal
- Non Executive Directors	Ritulal Kumar Seema Jain (Part of the Year) Renu Mittal (Part of the Year)



(b) Significant Related Party Transactions during the period (Rs. in Lakhs)

: Nil

Nature of Transaction	Key Management Personnel	Total
E Managerial Remuneration	182.96	182.96

FY 2004-05

(a) Names of related parties and nature of relationship

Category of related parties

Names

Holding Companies

nil

Subsidiaries of the Company

nil

Associates

- Company

Softprojex (India) Ltd

- Trust

Snehalathalal Family Welfare Trust

Key Management Personnel and their relatives

- Executive Directors

Dinesh Kumar

Aneesh Mittal

- Non Executive Directors

Ritulal Kumar

Seema Jain

Renu Mittal

(b) Significant Related Party Transactions during the period (Rs. in Lakhs)

: Nil

Nature of Transaction	Key Management Personnel	Total
E Managerial Remuneration	210.86	210.86

- Details of remuneration paid to Managing Director who is a related party is as follows:

Rs. 1,60,00,000/- . The remuneration payable to Mr. Diensh Kumar, Managing Director has been revised from Rs. 2,50,000/- per month to Rs. 12,50,000/- per month w.e.f. 1st June, 2004 and the necessary approval from the Central Government, Ministry of Company Affairs has been obtained vide its Letter No..... dated 1st December, 2004

FY 2003-04

(a) Names of related parties and nature of relationship

Category of related parties

Names

Holding Companies

Nil

Subsidiaries of the Company

Nil

Associates

- Companies

LFM Engineering Private Limited (closed)

- Trust - Proprietor

Lakshmi Telecom Products (closed)

- Trust

Snehalathalal Family Welfare Trust

Key Management Personnel and their relatives

- Executive Directors

Dinesh Kumar, Managing Director

Aneesh Mittal, Wholetime Director

- Non Executive Directors

Ritulal Kumar

Renu Mittal

Seema Jain



(b) Significant Related Party Transactions during the period: NIL

Details of Managerial Remuneration is as follows:

Remuneration to Managing Director / Wholetime Directors: Rs 36,45,294

(Excluding contribution to gratuity fund provision for leave encashment on retirement and other retirement benefits and inclusive of sitting fee of Rs. 66,000/-)

FY 2002-03

(a) Names of related parties and nature of relationship

Category of related parties	Names
Holding Companies	Nil
Subsidiaries of the Company	Nil
Associates	
• Companies	LFM Engineering Private Limited (being closed)
• Trust - Proprietor	Lakshmi Telecom Products (being closed)
• Trust	Snehalathalal Family Welfare Trust
Key Management Personnel and their relatives	
- Executive Directors	Dinesh Kumar, Managing Director Aneesh Mittal, Wholetime Director
- Non Executive Directors	Ritural Kumar Renu Mittal Seema Jain

(b) Significant Related Party Transactions during the period (Rs. in Lakhs)

Nature of Transaction	Trust	Key Managerial Personnel	Total
A Outstanding Balance included in Current Assets	88.54		88.54
B Outstanding as at the end	88.54		88.54
C Managerial Remuneration		53.99*	53.99
D Remuneration to Key Management Personnel other than given at (C) above		13.43	13.43
D Expenditure			

* Excluding contribution to gratuity fund, provision for encashment on retirement and other retirement benefits and inclusive of sitting fee of Rs. 28,000/-

FY 2001-02

(a) Names of related parties and nature of relationship

Category of related parties	Names
Holding Companies	Nil
Subsidiaries of the Company	Nil
Associates	
• Companies	LFM Engineering Private Limited
• Trust - Proprietor	Lakshmi Telecom Products
• Trust	Snehalathalal Family Welfare Trust



Key Management Personnel and their relatives

- Executive Directors Dinesh Kumar, Managing Director
Aneesh Mittal, Wholetime Director
- Non Executive Directors Ritural Kumar
Renu Mittal
Seema Jain

(b) Significant Related Party Transactions during the period

(Rs. in Lakhs)

Nature of Transaction	LFM	Trust	LTP	Key Management Personnel	Total
A Loans-Taken/ (repaid)				6.50 (6.08)	6.50 (6.08)
B Purchase of finished / unfinished goods	71.26		32.09		103.35
C Managerial Remuneration				6.64*	6.64
D Remuneration to Key Management Personnel other than given at (C) above				0	0
E Re-imbursement of Expenses / Cost of Material / Stores	37.74		30.10		67.84
F Outstanding Balance included in Current Assets	33.53	320.34			353.87
G Outstanding Balance included in Current Liabilities			1.99		1.99
H Rent for residential Flat Leased to Company				0.60	0.60
I Outstanding as at the end	33.53	320.34	1.99		355.86

*Excluding contribution to gratuity fund, provision for encashment on retirement and other retirement benefits and inclusive of sitting fee of Rs. 16,000/-

- (7) The Company operates in single segment of Telecom products till the recent results. However once the revenues start from Ethanol division, the company will report on segment wise revenue bifurcation as per law.
- (8) In the opinion of the Board the current assets, loans and advances are approximately of the value stated and are realizable in the ordinary course of business. The provision for all known liabilities is adequate.
- (9) The previous year's figures have been regrouped and rearranged, wherever necessary



Annexure – IV
Statement of Cash Flow

Particulars	for the period ended 30th June (Rs. in Lakh)				
	FY 2002	FY 2003	FY 2004	FY 2005	FY 2006
Cash Flow from Operating Activities (A)					
Profit before Tax	416.92	171.03	526.30	1072.46	1381.71
Adjustments for:					
Loss on Sale of Fixed Assets					
Depreciation and Amortisation	58.25	82.48	99.87	128.57	154.82
Interest, Dividend and Miscellaneous Income	-37.96	-50.77	-36.73	-52.26	-66.20
Interest and financial charges	309.53	582.32	907.36	1235.29	1182.11
Miscellaneous Expenditure Written Off					
Earlier Year Taxation	0.00				
Operating Profit before Working Capital Changes	746.74	785.06	1496.8	2384.06	2652.44
Adjustments for:					
(Increase) / Decrease in Inventories	-222.68	4.22	222.14	-604.68	-2759.11
(Increase) / Decrease in Debtors	-832.35	-1634.94	-566.23	-1173.27	-3926.15
(Increase) / Decrease in Loans and Advances	-255.89	255.62	191.93	56.75	-202.27
(Increase) / Decrease in Current Liabilities and Provisions	294.99	-153.89	712.21	-542.58	1738.74
(Increase)/Decrease in Miscellaneous Expenditure Written Off					
Cash Generated from Operations	-269.19	-743.93	2056.85	120.28	-2496.35
Tax Paid (Net of Refund)	38.64	20.00	58.37	365.00	310.00
Net Cash Flow from Operating Activities	-307.83	-763.93	1998.48	-244.72	-2806.35
Cash Flow from investing Activities (B)					
(Purchase) / Sale of Fixed Assets (net)	-670.01	-243.41	-680.81	-265.39	-41.35
(Purchase) / Sale of Investments (net)	0.00	1.94	-3.17	0.00	3.17
Interest and Dividend Income Received	37.96	50.77	36.73	52.26	66.20
Proceeds on disposal of Fixed Assets					
Net Cash Flow from Investing Activities	-632.05	-190.7	-647.25	-213.13	28.02
Cash Flow from Financing Activities (C)					
Proceeds from Issue of Share Capital	0.00	0.00	0.00	0.00	242.61
Proceeds from Share Premium					3609.4
Proceeds from Secured Loans	1362.55	1378.64	177.31	1506.49	484.18
Proceeds from Unsecured Loans					
Interest Paid	-309.53	-582.32	-907.36	-1235.29	-1182.11
Net Cash Flow from Financing Activities	1053.02	796.32	-730.05	271.2	3154.08
Net (Decrease) / (Increase) in Cash and Cash Equivalents (A+B+C)	113.14	-158.31	621.18	-186.65	375.75
Cash and Cash Equivalents at the Beginning of the Year	444.86	557.99	399.68	1020.86	834.21
Cash and Cash Equivalents at the end of the Year	558	399.68	1020.86	834.21	1209.96



Annexure –V

Statement of Sundry Debtors (Unsecured and Considered Good)

(Rs. in Lakh)

Particulars	for period ending June 30th				
	FY 2002	FY 2003	FY 2004	FY 2005	FY 2006
Exceeding Six Months	110.16	725.83	462.67	1542.61	243.81
Other Debts	1477.30	2496.57	3325.96	3419.29	8644.23
Total	1587.46	3222.40	3788.63	4961.90	8888.04

Annexure - VI

Statement of Loans and Advances

(Rs. in Lakh)

Particulars	for period ending June 30th				
	FY 2002	FY 2003	FY 2004	FY 2005	FY 2006
Advance recoverable in cash or kind or for value to be received	561.40	269.16	79.41	134.62	323.64
Deposits	58.19	30.69	38.94	74.21	87.36
Advance to suppliers	104.62	168.75	83.32	11.10	11.20
Advance Tax	0.00	0.00	75.00	0.00	0.00
Total	724.21	468.60	276.67	219.93	422.20

Above sundry debtors and Loans and advances does not include any party who are related to Promoters or Directors of the Company.



Annexure – VII

Statement of Secured Loans

A - Term Loans

Particulars of Loan	Bank	Nature of Loan	Sanctioned Amount	Outstanding	Rate of Interest P.A.	Repayment of Terms	Securities offered
Term Loans	IDBI	Term Loan-1	700	245	11.00%	June 2003 to March 2008 Rs. 35 Lakh per month (20 installments)	1st Charge on Fixed Assets of SMPS and Unexpanded Profile and 2nd charge on Movables Assets & Equity Shares held by Trust
	IDBI	Term Loan-2	1000	800	12.00%	October 2005 to July 2010 Rs. 50 Lakh per month (20 installments)	1st Pari Passu Charge on Fixed Assets of SMPS and Unexpanded Profile and 1st Pari Passu Charge on current Assets of the company & Equity Shares held the Trust
Term Loan	Vijaya Bank	Term Loan-3	400	311.16	14.00%	48 monthly installments of Rs. 8.33 Lakh per month from April 2005	Exclusive 1st Charge on fixed assets of Ethanol Unit of the Company located at Nanded Maharashtra, 1st pari passu charge on Assets located in Shed 30,31 & 32 IDA Mallapur & 2nd Pari Passu charge on Fixed Assets located in Cherlapalli

B. Working Capital Loans

Working Capital Facility	Canara Bank	Cash Credit	1160	1339.28	11.00%	Secured by hypothecation of the Company's entire current assets and collateral security of specified immovable assets of the Company and the Promoters
	Federal Bank	Cash Credit	667	828.72	12.50%	
	Vijaya Bank	Cash Credit	493	727.3	11.25%	
	SBH	SBP	290	403.54	11.25%	
	IOB	Cash Credit	290	419.65	11.25%	
Hire Purchase Loans	ICICI Bank			18.36	7%	Secured by hypothecation of specified vehicles against which the finance is obtained



Annexure - VII (Contd.)

Details of Secured Loans

Particulars	for period ending June 30th (Rs. in Lakh)				
	FY 2002	FY 2003	FY 2004	FY 2005	FY 2006
Working Capital					
Canara Bank SBP	433.84	399.89	1025.53	1424.46	
Canara Bank CC	198.80	204.80	39.32	34.70	1339.28
Federal Bank SBP	441.08	837.06	635.41	920.99	
Federal Bank CC	52.84	95.01	93.13	136.10	828.72
Vijaya Bank SBP	122.69	0.00	438.13	457.00	
Vijaya Bank CC	67.89	0.00	255.61	68.85	727.30
Indian Overseas Bank SBP			0.00	290.00	
Indian Overseas Bank CC			0.00	18.27	419.65
State Bank of Hyderabad		80.92	293.46	290.00	
State Bank of Hyderabad CC		39.55	19.93	16.38	403.54
DEV. CR Bank CC	37.93		0.00	0.00	
DEV. CR Bank SBP	117.37				
Export Bills Discount - Federal Bank		7.28	15.93	0	
Bank of Nova Scotia		91.51			
BNS-CDMA-SBP		1083.75			
IDBI Short Term Loan					650.00
Term Loans					
IREDA	11.45	10.23	7.98	6.18	4.38
IDBI Term Loan	350.00	700.00	525.00	385	245.00
IDBI Bank Bridge Loan	350.00				0.00
IDBI Corporate Loan				800	800.00
Vijaya Bank Term Loan			394.17	394.17	311.16
Interest Accrued & Due		25.58	4.32	4.6	11.74
Hire Purchase Loans					
Kotak Mahindra Finance Ltd	6.66	7.77	2.87		
Standard Chartered Bank	0.19				
Ford Credit Kotak Mahindra					
ICICI LTD			17.18	28.24	18.36
HSBC Ltd	21.78	7.79			
Total (A)	2212.52	3591.16	3767.97	5274.96	5759.13



Annexure – VIII

Statement of Unsecured Loans

There are no unsecured loans from the Directors or any other person for the entire period.

Annexure – IX

Statement of Operational Income

(Rs. in Lakh)

Particulars	for period ending June 30th				
	FY 2002	FY 2003	FY 2004	FY 2005	FY 2006
CDMA Mobile Phones	0.00	3532.85	20425.55	25754.64	33674.09
Mobile Accessories	0.00	34.00	61.52	100.23	0.00
SMPS Systems	447.68	1059.14	701.64	1730.64	569.86
Jointing Kits & Components	1638.06	994.51	121.80	591.19	434.87
Optic Fibre Accessories	867.13	326.00	174.97	83.61	84.05
Export Sales	36.22	213.21	40.41	1885.87	21.07
Solar Photovoltaic Systems	2126.77	539.30	328.06	113.23	98.62
Ethanol	0.00	0.00	0.00	0.00	5938.14
Other Sales	36.58	0.00	0.00	0.00	0.00
Total	5152.44	6699.01	21853.95	30259.41	40820.70
LESS: TAXES & DUTIES					
Sales Tax	114.39	111.38	353.10	396.19	1132.77
Excise Duty	154.77	213.36	106.38	171.87	158.86
Net Operational Income	4883.28	6374.27	21394.47	29691.35	39529.07

Annexure - X

Statement of Other Income

(Rs. in Lakh)

Particulars	for period ending June 30th				
	FY 2002	FY 2003	FY 2004	FY 2005	FY 2006
Interest Received	15.07	26.67	25.43	47.76	50.53
Miscellaneous Income	13.91	17.42	8.27	1.24	3.15
Sale of Scrap	8.98	6.68	3.03	3.26	12.52
Total	37.96	50.77	36.73	52.26	66.20



Annexure - XI

Statement of Contingent Liabilities

(Rs. in Lakh)

Particulars	for period ending June 30th				
	FY 2002	FY 2003	FY 2004	FY 2005	FY 2006
Bank Guarantee's/Counter Guarantee's	658.20	1210.13	1660.68	1802.06	2215.83
Letter of Credits	0.00	0.00	9.00	66.77	3956.96
Estimated Amount of contracts remaining to be Executed on capital account (net of advance) not provided for amounting to	0.00	0.00	94.99	0.00	0.00
Total	658.20	1210.13	1669.68	1868.83	6172.79

Annexure XII

Statement of Accounting Ratios

(Rs. in Lakh)

Particulars	for period ending June 30th				
	FY 2002	FY 2003	FY 2004	FY 2005	FY 2006
Face Value per Share (Rs)	10	10	10	10	10
Earnings Per Share (Rs) (annualized for the 2006)	11.31	0	13.46	17.76	10.25
Cash Earnings Per Share (Rs)	13.05	6.98	16.97	24.99	11.63
Return on Networth (%) (Annualized for 2006)	23.30%	8.51%	11.06%	20.14%	13.73%
Net Asset Value Per Share (Rs)	48.53	53.04	67.03	88.18	74.68

Notes:

The Ratios have been calculated as below

EPS = a/b

Return on Net worth = a/d %

Net asset Value Per share = e/b

a. Net Profit after Tax

b. Weighted Average number of Equity shares outstanding during the year

c. Cash earning = Net Profit after tax add depreciation, preliminary expenses written off and deferred tax liability

d. Net worth=Equity share Capital plus reserve and surplus less miscellaneous expenditure to the extent not written off

e. Net Asset=Equity share capital plus reserve and surplus less miscellaneous expenditure to the extent not written off

Earnings per Share is computed in accordance with Accounting Standard 20 "Earnings per Share" issued by the Institute of Chartered Accountants of India.

Annexure – XIII

Statement of Capitalisation

Rs in Lakh

Particulars	Pre-Issue As at June 30, 2006	Post Issue*
Debt		
Short-term Debt	4368.49	
Long -term Debt	1390.64	
Total (A)	5759.13	
Shareholders' Funds		
Share Capital	1054.32	●
Share Application Money Pending allotment	2227.00	



Particulars	Pre-Issue As at June 30, 2006	Post Issue*
Reserves and Surplus		
Reserves and Surplus after deducting Miscellaneous Expenditure not written off	6819.43	[●]
Total Shareholders' Funds (B)	7873.75	[●]
Long Term Debt / Total Shareholders' Funds (A/B)	0.1766	

Note:

Share Capital was increased from Rs. 335.56 Lakh to Rs. 1054.32 Lakh by issue of further shares on premium after January 31, 2006 and a Bonus Issue and again further issue in May 2006.

* Information pertaining to Share Capital and Reserves post-Issue can be ascertained only after completion of Book Building process.

Annexure – XIV

Statement of Tax Shelters

Tax Calculations are for the Year Ended 31st March** (Rs. in Lakh)

Particulars	FY 2005	FY 2004	FY 2003	FY 2002	FY 2001
Profit before Tax as per books - (A)	419.92	144.89	41.17	5.23	427.10
Total Tax (%)	36.23	35.88	36.75	37.11	39.55
Tax at actual rate on book profits	152.14	51.98	15.13	1.94	168.92
Adjustments:					
Permanent Differences					
Donations	7.42	13.00	0.86	0.60	3.47
Tax Paid & Other Adjustments	307.39	64.94	30.50	95.45	27.95
Total Permanent Differences -(B)	314.81	77.94	31.36	96.05	31.42
Timing Differences					
Difference between Tax Depreciation and Book Depreciation	-125.10	-87.07	-52.55	2.82	7.51
Others	0.00	0.00	0.00	0.00	0.00
Total Timing Differences - (C)	-125.10	-87.07	-52.55	2.82	7.51
Net Adjustments - (B+C)	189.71	-9.13	-21.19	98.87	38.93
Tax Savings thereon	68.73	-3.28	-7.79	36.69	15.40
Profit as per Income Tax Returns (D) = (A+B+C)	609.63	135.76	19.98	104.10	466.03
Taxable Income as per MAT	0.00	0.00	0.00	0.00	0.00
Tax as per Income Tax Returns	220.87	48.70	7.34	38.63	184.31

Note:

- The Company follows 1st July to 30th June as the Financial Year and for the purpose of Income Tax, however, the Returns have been computed and filed as per IT Act following 1st April to 31st March as the year.
- The Company was subject to search u/s. 132 of Income Tax Act, 1961, and the Company has made certain admissions which have been accepted by the Income Tax Department. The Company has filed the Block Assessment Return, in respect of the above matter.

The Company has already provided for Rs.365 Lakh of Income Tax payable as on 30.06.2005, which covers the total amount of Income Tax payable for the disclosures. There is no future impact of Tax Liability in respect of the search proceedings.



FINANCIAL INFORMATION OF GROUP COMPANIES

SoftProjex (India) Ltd

The Promoters of the Company has interests in other businesses like Software. The Promoters have established Software Company in Hyderabad to focus in Offshore Services in the year 2000. SoftProjex has a subsidiary in US. SoftProjex combined revenues are of the order of Rs.1500 Lakhs with an Equity of Rs.480 Lakhs. SoftProjex has been awarded SEI CMM Level 5 certification during the last year. SoftProjex has the focus in BFSI, Healthcare and Automotive verticals with wide range of technologies.

M/s.Snehalata Lal Family Welfare Trust owns 100% of the Equity of the SoftProjex (India) Ltd

Board of Directors:

Name of the Director	Designation
Dinesh Kumar	Chairman & Managing Director
Ritu Lal Kumar	Director
Meenakshi Nagarajan	Director
Aneesh Mittal	Alternate Director to Meenakshi Nagarajan

Consolidated Financials

SoftProjex - Consolidated Financials

FY	Rs in Lakh			
	31.3.2005*	31.3.2004	31.3.2003	31.3.2002
	Estimate	Audited	Audited	Audited
Net Sales	1678.59	1525.92	1364.34	332.09
EBIDTA	269.72	222.82	179.90	22.38
PAT 53.58	23.01	17.27	9.20	
Equity	470.73	470.73	470.73	470.73
Reserves & Surplus	111.68	58.10	35.09	17.82
Net worth	582.41	528.83	505.82	488.55
EPS (Rs.)	1.14	0.49	0.37	0.20
Book Value	12.37	11.23	10.75	10.38
EBIDTA %	16.07%	14.60%	13.19%	6.74%
PAT %	3.19%	1.51%	1.27%	2.77%

*Financial Statements for the year 31.3.2005 have not been completed since the Income Tax Dept conducted search on the company and hence the Books of Accounts are not available to complete the same.

There is no Promoter Group Company which has become sick within the meaning of the Sick Industrial Companies (Special Provision) Act, 1955. Additionally there is no Group Company that was referred to erstwhile BIFR or under the process of winding up.



MANAGEMENT'S DISCUSSION AND ANALYSIS OF FINANCIAL CONDITION AND RESULTS OF OPERATIONS

You should read the following discussion and analysis of our financial condition and results of operations together with financial statements included in this Red Herring Prospectus. You should also read the section titled "Risk Factors" beginning on page xi of this Red Herring Prospectus, which discusses a number of factors and contingencies that could impact the financial condition and results of operations.

The following discussions are based on restated financial statements for the financial year ended June 30, 2002; June 30, 2003; June 30, 2004; June 30, 2005 and June 30, 2006. which have been prepared in accordance with Indian GAAP, the Companies Act and the SEBI (DIP) Guidelines and on information available from other sources.

The Directors confirm that there have been no events or circumstances since the date of the last financial statements which materially and adversely affect or are likely to affect the profitability of the Company or the value of its assets or its ability to pay its liabilities within the next twelve months except those disclosed on page 113 in this Red Herring Prospectus.

Overview of the business of the issuer company

XL Telecom Ltd (XL) is a established, profit making, Rs.30000 Lakhs Revenue, Telecom company engaged in manufacturing of Telecom Equipment, largely CDMA Mobile Handsets, SMPS Power Systems etc., as one of the dedicated suppliers for India Telecom Operators/Service Providers like TATA, Reliance, BSNL, MTNL etc., and Network Integrators like NORTEL, ERICSON etc. Currently Revenues from Telecom Segment being over 99%, as a strategy to de-risk, the Company has diversified its portfolio of products to new emerging products like Ethanol and Solar Photovoltaic Products. The Company was incorporated originally on 3rd October 1985 under the name of XL Cable Splices Private Limited and the name of the Company was changed to XL Telecom Private Ltd initially and then to XL Telecom Ltd effective 31st December 1990.

XL has divided its Business focus into 3 Strategic Business Units:

1. Telecom – Mobile Handsets, SMPS etc.,
2. Solar Photovoltaic Systems
3. Ethanol (Plant Just started Operations in First Quarter of 2006)

A. TELECOM:

A1. CDMA

During the year 2002 XL has diversified in to fast growing Indian Mobile segment and of it then emerging CDMA Mobile Market in Technical assistance with internationally renowned market leader Kyocera. The Company is the first to establish a manufacturing facility for CDMA Mobile handsets in India, as an Independent Company. XL has currently a capacity of about 10,000 Mobile Handsets per day and 3.5 Million Handsets per annum. XL has supplied several models and till date has sold over 1 Million Handsets to all the players like TATA, MTNL and BSNL. XL has a market share of about 50% in the TATA since launch and close to 100% market share with MTNL for 3 years and over all about 10% market share in the Indian CDMA Market Segment. During the current fiscal XL is looking at launching several high-end models into Indian Market and has established a relationship with all the players including of Reliance to market these models in the OPEN Market segment in line with competitor NOKIA. XL is in the process of establishing the Distribution Network to reach the vast Indian Customer Base.

A2. JOINTING KITS & OFC EQUIPMENT

The company initially focused in Outside Plant accessories and more specifically Jointing Kits for PIJF Cables in the year 1985. In 1990, the company has established state-of-the-Art manufacturing facility to manufacture Heat Shrink Sleeves, the main component in the Jointing Kit, as backward integration project in Technical and Financial assistance with the then German Major SIEMENS through its subsidiary M/s. RXS Kabelgarniturien GmbH, Germany. The Project involved total capital outlay of about Rs.900 lakhs, funded by Rs.500 Lakhs Loans from Financial Institutions and Rs. 100 Lakh Equity from Collaborator and Rs.100 Lakh Equity from Financial Institutions. The Company has created the largest capacity for HS Sleeves in the country to meet the then growing Telecom Needs of the Country. During the next decade the Company went on to become the largest supplier of Jointing Kits in the Industry to Telecom Operators like Department of Telecom (DoT and Now BSNL) and Mahanagar Telecom Nigam Limited. The Company had a peak market share of about 40% for several years. XL also supplies various Optic Fiber Accessories like Fusion Splicing Equipment etc., to various Telecom Operators like BSNL, MTNL, Reliance etc.,



A3. SMPS POWER SYSTEMS

In 2000, the Company has diversified into Power Electronics, by establishing the world class manufacturing facility to produce Switch Mode Power Systems (SMPS). SMPS are generally used by DoT, MTNL and other Private Operators like Bharti, Reliance, IDEA, Hutch, TATA etc in their exchanges as well as BTS stations in the Mobile Segment. XL has entered in to technical assistance with Austrian Company. XL has an track record for supplying the best quality product to Network Integrators like NORTEL, ERICSON and SEIMENS. XL enjoys about 15 to 20% Market share in this segment.

B. SOLAR PHOTOVOLTAIC SYSTEMS:

In 1995, XL has established 'Solar Photovoltaic' Division for supplying the SPV Systems to Department of Telecom. DoT had come out innovative way of powering their Village Public Telephones through independent SPV Systems, to reach out the vast Rural India. Looking at the opportunity and leveraging the existing relationship with DoT, the Company has decided to diversify into this segment. The Company has invested about Rs.200 Lakhs in the Capital Expenditure through internal accruals, to create a world class Solar Photo Voltaic Module manufacturing plant, largely by buying out the SEIMENS India Plant. The Company has a capacity of about 3 MW per annum. The company received orders from DoT initially valued about Rs.3000 lakhs with in the first year of operation of the Unit and XL has successfully executed these orders in time. Later the Company has expanded its product offerings by getting into SPV Power Plants (Grid Based), SPV Home Lighting, Street Lighting and Solar Lanterns etc., and supplied to various Non-conventional energy agencies situated across the country. The Company is seeing potential in the Non-conventional energy segment internationally. The Company has entered into long term contract for supply of Solar Photo Voltaic Modules with a German Company for next 3 years and is looking to expand the current facilities to meet the international quality standards in addition to creating and expanding the capacity for establishing 100% EOU.

C. ETHANOL:

Government of India with a multi pronged strategy of

- (1) to give boost to agricultural sector
- (2) to reduce environmental pollution
- (3) to save the precious foreign currency
- (4) to reduce the Oil deficit and
- (5) to effectively reduce the Oil Pricing to consumers,

have announced a policy decision that 5% of Ethanol should be used as a blend in petrol at the supply locations of Oil Companies and initially this is made applicable to 9 States and Four Union Territories. With the current demand of about 13,360 million liters of Petrol, the Ethanol demand is working out to be about 668 million liters. Looking at the opportunity thrown open by GOI, XL has immediately established an independent Ethanol Manufacturing Plant with the largest capacity of 1,50,000 liters capacity per day in India. The Plant is fully operational and has got the clearance from OIL Companies as well. XL has participated in the various tenders called for by Oil Companies and is expecting orders to be released in couple of weeks. Ethanol division has started receiving its first orders and is expected to do about Rs.9000 lakhs revenue during the fiscal 2005-06. With its position as L1 Bidder in the Tender, XL is confident of reaching the projected revenues. XL has invested about Rs.900 lakhs in the Project with about Rs.400 lakhs as Term Loan and the balance from Internal Accruals.

Significant Development Subsequent to the Last Financial Year

There some significant developments subsequent to the last audited balance sheet for the 7 Month period ending 30.6.2006 and the same are:

- The Company had received Purchase Order Valued over Rs.9659 Lakh for supplies of 358,164 Fixed Wireless Phones from Bharat Sanchar Nigam Ltd and the same is in advanced stage of completion. Based on the further requirements, BSNL has called the company for price negotiation for a potential repeat order of same quantity and about same value.
- The Company has participated in the Maharashtra Tender for supply of Ethanol for a period of 3 years ending 31.10.2009 and has been positioned itself as L1 Bidder and become eligible to receive orders of 450 Lakh Its each for the year 2007-08 and 2008-09 and 262.50 Lakh Its for the period 1.4.2009 to 31.10.2009 as per Tender conditions.
- The Company has received a Firm Purchase Order from Forta Imports and Exports S.L. for supply of 66,667 Solar Photovoltaic Modules of 180 Wp.totalling 12 MW and valued Euro 42 Million equivalent to Rs.22050 Lakh to be supplied between July 2007 to Dec 2009.
- The Company has received a Pilot Order for supply of Fixed Wireless Phones to Reliance Infocom, country's Private CDMA Operator valued over Rs.578.50 Lakh.



Factors that may affect results of the Operation

Operating risks of the Company include competition from the foreign and Indian service providers that offer similar services at competitive prices. It also regards changes in political, economic and social conditions that may lead to change in taste, preference or restrictive legislation as an operating risk. Changes in infrastructure conditions like disruption in the power supply, IT infrastructure and telecom lines due to industrial reason or acts of god may affect the operations. Finally the financial operations of the company are exposed to the risks of interest rate and exchange rate fluctuations.

The management of the Company makes best effort to minimize the risks. These include continuous strategising of market competitiveness and enhancing technical efficiency through training and technology upgrade. The infrastructure risks are minimised by building appropriate redundancy, backups, contingency and disaster recovery programs. However, it is to be understood that best efforts can only minimize the operation risks and not vacate them entirely.

Discussion on Results of Operations

A summary of our past financial results based on our Restated Accounts is given below:

Annexure II

Statement of Restated Profits and Losses

(Rs. In Lakh)

	Year ended June, 30				
	2002	2003	2004	2005	2006
Income					
Sales :					
Of products manufactured by the Company	4002.21	6054.96	21219.50	29607.75	39445.02
Of products traded in by the Company	881.07	319.31	174.97	83.60	84.05
Total	4883.28	6374.27	21394.47	29691.35	39529.07
Other income	37.96	50.77	36.73	52.26	66.20
	4921.24	6425.04	21431.20	29743.61	39595.27
Expenditure					
Raw Materials consumed	3417.55	4840.05	18690.57	25908.31	34795.68
Staff Costs	262.36	317.99	365.61	385.19	490.80
Other manufacturing expenses	29.57	29.10	37.58	56.93	83.07
Depreciation	58.25	82.48	99.87	128.57	154.82
Administration Expenses	252.47	289.83	445.07	626.23	805.98
Selling and Distribution Expenses	194.19	112.24	358.84	330.63	701.10
Interest	309.53	582.32	907.36	1235.29	1182.11
Total	4523.92	6254.01	20904.90	28671.15	38213.56
Net Profit before tax and extraordinary items	397.32	171.03	526.30	1072.46	1381.71
Prior Period Adjustment	19.60				
Taxation	38.64	20.00	58.37	365.00	310.00
Net Profit before deferred tax	378.28	151.03	467.93	707.46	1071.71
Add/Less deferred Tax	0.00	0.00	220.00	113.41	-9.33
Net Profit after adjusting deferred tax	378.28	151.03	247.93	594.05	1081.04



Comparison of Results for FY 2006 with FY 2005

Operational Income

The operational income net of excise duty and sales tax for the year stood at Rs.39445.02 Lakh.

The Growth in the topline is of the order of 33.32% from the previous year Rs.29607.75 Lakh. The Company has largely seen good growth in the revenues due to increased demand in the CDMA handset requirements of the country due to exponential growth being seen in Mobile growth in the country. Further during the year the Company has started the Ethanol Operations and recorded revenues of Rs.5938.14 Lakh.

Other Income

Other Income for the Financial year 2006 stood at 66.20 Lakh compared to the previous year of Rs.52.26 Lakh, it has shown in absolute terms a growth rate of 26.67%. Other Income normally includes only the Interest received on the Fixed Deposits of the Company given as Margin Moneys towards the LC's and BG's. In view large PSU based business the Company needs to give BG's for both Bid Bond and Performance Guarantee extending up to 3 years in many cases, and hence the Interest earning is more or less recurring in Nature. Miscellaneous Other Income is normally represents of Income received by sale of scrap etc., which is non-recurring in nature.

Expenditure

During the year 2006 the direct total expenditure stood at 91.97% to the Income from Operations and compared to the previous year figure of 93%, the company did see marginal improvement in reducing the overall expenditure and increasing the savings by about 1%, which largely can be attributed to Savings in Staff Costs by about 0.4% of total Income and similarly about 0.57% savings in the selling and Distribution expenses. The Company could largely attribute these savings to increased volumes and hence better negotiation in the logistic expenditure of the company.

Interest and Financial Charges

Interest and financial charges comprise of interest payments to banks and financial institutions, others and bank charges. In absolute terms interest and financial charges for the financial year 2006 stood at Rs. 1182.11 Lakh and it is about 2.99% of Sales. The Interest costs have come down in % terms to the sales compared to the previous year figure of 4.16% showing good improvement in working capital utilization.

Depreciation

In absolute terms depreciation for the financial year 2006 stood at Rs.154.82 Lakh. The company has witnessed increase in absolute percentage by about 20.42% compared to the previous year.

Profit before Tax

The Company's net profit before tax for the financial year 2006 in absolute term stood at Rs.1381.71 Lakh compared to Rs.1072.46 Lakh for the previous year showing 28% growth in the current fiscal in line with the Sales Growth. The company improved Profits by over 28% compared to the previous year largely due to increased revenues, while maintaining the costs at more or less same as previous year.

Working Capital Utilization like Inventories, Receivables and Liabilities

Working Capital	FY 2006	FY 2005	No of days of sales
Inventories	3978.50	1219.40	37 days
Sundry Debtors	8888.05	4961.90	82 days
Cash & Bank Balances	1209.96	834.21	
Loans & Advances	422.19	219.93	4 days
Total	14498.70	7235.44	
Less:			
Liabilities	2299.15	869.29	21 days
Provisions	678.10	355.35	
Sub Total	2977.25	1224.64	
Net Working Capital	11521.45	6010.80	



During the financial year 2006, the Company has entered into Retail marketing of CDMA Phones and also commenced the supplies of Ethanol. Both these initiatives needed different approach and the company in line the business needs started building inventories and necessity to give credit, in addition to giving advances in the Ethanol business to procure raw materials. Further this is the first year in which Fixed Wireless Business has also got initiated as part of CDMA Phones necessitating certain investment through advances in vendor creation.

Inventories : Though in absolute terms there is jump in Inventories the same is well within the Industry norms and was absolute necessary in the changed business composition and it accounts for 37 days of Sales for the year.

Receivables : Similarly, though in absolute terms there is jump in receivables the same is well within the Industry norms and was absolute necessary in the changed business composition especially in the Retails business and it accounts for 82 days of Sales for the year.

Liabilities : As explained above, to compensate for the incremental investments by the company in Inventories and Receivables, we have negotiated and taken credit form our suppliers as well and it accounts to 21 days of Sales.

Advances : Ethanol Business Needed Investments in advances to suppliers since Sugar Market is always worked across the India in Advance Payment and hence the surge in this area.

Comparison of FY 2005 with FY 2004

Operational Income

The operational income net of excise duty and sales tax for the year stood at Rs.29691.36 Lakh.

The Growth in the topline is of the order of 38.78% from the previous year Rs.21394.47 Lakh. The Company has largely seen good growth in the revenues due to increased demand in the CDMA handset requirements of the country due to exponential growth being seen in Mobile growth in the country.

Other Income

Other Income for the Financial year 2005 stood at 52.25 Lakh compared to the previous year of Rs.36.74 Lakh, it has shown in absolute terms a growth rate of 42.22%. Other Income normally includes only the Interest received on the Fixed Deposits of the Company given as Margin Moneys towards the LC's and BG's. In view large PSU based business the Company needs to give BG's for both Bid Bond and Performance Guarantee extending up to 3 years in many cases, and hence the Interest earning is more or less recurring in Nature. Miscellaneous Other Income is normally represents of Income received by sale of scrap etc., which is non-recurring in nature.

Expenditure

During the year 2005 the direct total expenditure stood at 91.97% to the Income from Operations and compared to the previous year figure of 93%, the company did see marginal improvement in reducing the overall expenditure and increasing the savings by about 1%, which largely can be attributed to savings in Staff Costs by about 0.4% of total Income and similarly about 0.57% savings in the selling and Distribution expenses. The Company could largely attribute these savings to increased volumes and hence better negotiation in the logistic expenditure of the company.

Interest and Financial Charges

Interest and financial charges comprise of interest payments to banks and financial institutions, others and bank charges. In absolute terms interest and financial charges for the financial year 2005 stood at Rs. 1235.29 Lakh and it is about 4.16% of Sales. The Interest costs have come down in % terms to the sales compared to the previous year figure of 4.24% showing marginal improvement in working capital utilization.

Depreciation

In absolute terms depreciation for the financial year 2005 stood at Rs.128.57 Lakh. The company has witnessed increase in absolute percentage by about 29% compared to the previous year. This is largely due to capitalization of the Company's Ethanol project during the year.

Profit before Tax

The Company's net profit before tax for the financial year 2005 in absolute term stood at Rs.1072.46 Lakh compared to Rs.526.30 Lakh for the previous year showing substantial growth in the current fiscal. The company improved Profit by over 100% compared to the previous year largely due to increased revenues, while maintaining the costs at more or less same as previous year. In absolute percentage the company achieved a profit of 3.61% on the total income compared to previous year figure of 2.46%, showing a tremendous improvement in overall performance of the company.



Comparison of FY 2004 with FY 2003

Operational Income

The operational income net of excise duty and sales tax for the year stood at Rs.21394.47 Lakh.

During the year the Company witnessed Growth in the topline and it is of the order of 235.64% from the previous year revenues of Rs.6374.27 Lakh. The Company has largely seen good growth in the revenues due to increased demand in the CDMA handset requirements of the country due to exponential growth being seen in Mobile growth, while the remaining products did show reasonably good growth rates. During the year the Company received good orders from the Private Carriers like TATA Indicom in addition to PSUs like BSNL and MTNL. The Company's products were well received in the Market and the Kyocera Brand is established in the year.

Other Income

Other Income for the financial year 2004 stood at Rs.36.73 Lakh compared to the previous year of Rs.50.77 Lakh, it has shown in absolute terms a decline over previous year largely due to fall in the sale of scrap amount during the current year. Other Income normally includes only the Interest received on the Fixed Deposits of the Company given as Margin Monies towards the LC's and BG's. In view large PSU based business the Company needs to give BG's for both Bid Bond and Performance Guarantee extending up to 3 years in many cases, and hence the Interest earning is more or less recurring in Nature. Miscellaneous Other Income is normally represents of Income received by sale of scrap etc., which is non-recurring in nature.

Expenditure

During the year 2004 the direct total expenditure stood at 93% to the Income from Operations and compared to the previous year figure of 87.68%. The huge rise in the expenditure is entirely due to increase in the Raw Material Consumption for the year which as a % to sales has been of the order of 87.36% compared to previous year 75.93% it has increased over 11% in absolute terms. This is due to the fact that the company has increased its revenues in CDMA segment where the Gross Margins are about 12% and hence increase in the Raw Materials costs. CDMA Handsets are currently manufactured in the company by importing in SKD model and hence are at higher cost. However, due to increased sales the company did save to a certain extent in staff costs as a percentage to sales and also the Administrative Costs by about 2.5% of sales.

Interest and Financial Charges

Interest and financial charges comprise of interest payments to banks and financial institutions, others and bank charges. In absolute terms interest and financial charges for the financial year 2004 stood at Rs. 907.36 Lakh and it is about 4.24% of Sales. The Interest costs have come down in % terms to the sales compared to the previous year figure of 9.14% showing substantial improvement in working capital rotation especially due to growth in revenues.

Depreciation

In absolute terms depreciation for the financial year 2004 stood at Rs.99.87 Lakh. The company has witnessed increase in absolute percentage by about 21% on per month basis compared to the previous year. This is largely due to capitalization of the Company's capital equipments during the year.

Profit before Tax

The Company's net profit before tax for the financial year 2004 in absolute term stood at Rs.526.30 Lakh compared to Rs.171.03 Lakh for the previous year showing substantial growth of over 200% in the current fiscal. The company improved Profit by over 200% compared to the previous year largely due to increased revenues while maintaining the costs (other than Raw Materials) at more or less same or at best saved to a certain extent compared to previous year.

Comparison of FY 2003 with FY 2002

Operational Income

The operational income net of excise duty and sales tax for the year stood at Rs.6374.27 Lakh.

During the year the Company witnessed good Growth in the topline and it is of the order of 30.53% from the previous year revenues of Rs4883.28 Lakh. The Company has largely seen good growth due to Company's new product introduction and that is CDMA Sales. The Company has received and executed orders worth Rs.3501.16 Lakh in the CDMA segment alone. During the year the Company introduced Kyocera make CDMA handsets in the country and has won tenders from the PSU companies like BSNL and MTNL. The Company has established SKD manufacturing facility during the year and also established good after sales service centers to tackle the post sales issues. The Company had to diversify in to growth areas in view of shrinking Jointing Kit Market over the years. This Jointing Kit segment has seen huge fall from Rs.1638 Lakh revenues in the previous year 2002 to 994.51 Lakh in the current fiscal and similarly fall in OFC Accessories too. Despite this fall in the existing business the Company did achieve a good growth in the over all sales due to sensible diversification into CDMA segment, which should ensure good growth opportunities over the next few years.



Other Income

Other Income for the financial year 2003 stood at Rs.50.77 Lakh compared to the previous year of Rs.37.96 Lakh, it has shown in absolute terms a 34% growth over previous largely due to incremental sale of scrap during the current year. Other Income normally includes only the Interest received on the Fixed Deposits of the Company given as Margin Monies towards the LC's and BG's. In view large PSU based business the Company needs to give BG's for both Bid Bond and Performance Guarantee extending up to 3 years in many cases, and hence the Interest earning is more or less recurring in Nature. Miscellaneous Other Income is normally represents of Income received by sale of scrap etc., which is non-recurring in nature.

Expenditure

During the year 2003 the direct total expenditure stood at 87.68% to the Income from Operations and compared to the previous year figure of 85.11% showing a marginal increase in the overall expenditure due change in the composition of product sales. This is due to the fact that the company has for the first time has started getting its revenues in CDMA segment where the Gross Margins are lower than the existing product range. In absolute terms the % of increase in Raw Materials consumption as a percentage of Sales has gone up by about 6%. CDMA Handsets are currently manufactured in the company by importing in SKD model and hence are at higher cost. However, due to increased sales the company did save to a certain extent in selling distribution costs by about 2%.

Interest and Financial Charges

Interest and financial charges comprise of interest payments to banks and financial institutions, others and bank charges. In absolute terms interest and financial charges for the financial year 2003 stood at Rs. 582.32 Lakh and it is about 9.14% of Sales. The Interest costs have gone in % terms to the sales compared to the previous year figure of 6.34% due to growth in revenues and especially utilization of both BG and LC facilities due to large orders from BSNL and MTNL for CDMA products, where we had to submit three year BG for 5% of value of order for performance guarantee and also open foreign Letter of Credit for importing SKD sets of CDMA with 14 month payout period for 20% value of the imports, since the BSNL gives a deferred payment of Invoices to the extent of 20%. These huge charges has increased the over all expenditure under interest and financial charges.

Depreciation

In absolute terms depreciation for the financial year 2003 stood at Rs.82.48 Lakh. The company has witnessed increase in absolute percentage by about 41% on per month basis compared to the previous year. This is largely due to capitalization of the Company's capital equipments meant for CDMA Assembly during the year.

Profit before Tax

The Company's net profit before tax for the financial year 2003 in absolute term stood at Rs.171.03 Lakh compared to Rs.397.32 Lakh for the previous year showing substantial fall of over 56% in the current fiscal. In absolute % to the Total Income the profits for the year were about 2.66% compared to 8.07% for the previous year. The fall in the profit was largely due to change in the product mix and fall in the revenues of jointing kits and OFC accessories, which had better Gross Margins.

Comparison of FY 2002 with FY 2001

Operational Income

The operational income net of excise duty and sales tax for the year stood at Rs.4883.28 Lakh.

During the year the Company witnessed nominal Growth of 7.57% in the top line compared to the previous year revenues of Rs. 4539.62 Lakh. The Company has largely seen good growth in Solar Systems Sales (Rs.2126.77 Lakh compared to previous year Rs. 282.63 Lakh) and SMPS Systems (Rs.447.68 Lakh compared to meager Rs.1.08 Lakh). However, due to fall in the demand and tender position of the Company during the year Revenues from Jointing Kits (Rs.1660.70 Lakh compared to previous year Rs.3134.30 Lakh) and OFC Accessories (Rs.890.05 compared to previous year Rs.1469.74 Lakh) have witnessed down fall.

Other Income

Other Income for the financial year 2002 stood at Rs.37.96 Lakh compared to the previous year of Rs.72.11 Lakh, it has shown in absolute terms a fall of 47% over previous period largely due less sale of scrap during the current year. Other Income normally includes only the Interest received on the Fixed Deposits of the Company given as Margin Monies towards the LC's and BG's. In view large PSU based business the Company needs to give BG's for both Bid Bond and Performance Guarantee extending up to 3 years in many cases, and hence the Interest earning is more or less recurring in Nature. Miscellaneous Other Income is normally represents of Income received by sale of scrap etc., which is non-recurring in nature.



Expenditure

During the year 2002 the direct total expenditure stood at 85.11% to the Income from Operations and compared to the previous year figure of 87.79% showing a marginal improvement in the overall expenditure savings largely due to change in the composition of product sales.. This is due to the fact that the company has for the first time has started getting its revenues in SMPS segment.

Interest and Financial Charges

Interest and financial charges comprise of interest payments to banks and financial institutions, others and bank charges. In absolute terms interest and financial charges for the financial year 2002 stood at Rs. 309.53 Lakh and it is about 6.34% of Sales. The Interest costs have gone up in % terms to the sales compared to the previous year figure of 3.60% largely due to growth in revenues and especially utilization of both BG and LC facilities due to large orders from BSNL and MTNL, where we had to submit three year BG for 5% of value of order for performance guarantee and also open foreign Letter of Credit for importing components for SMPS.

Depreciation

In absolute terms depreciation for the financial year 2002 stood at Rs.58.25 Lakh. The company has witnessed increase in absolute percentage by about 13% on per month basis compared to the previous year. This is largely due to capitalization of the Company's capital equipments meant for SMPS during the year.

Profit before Tax

The Company's net profit before tax for the financial year 2002 in absolute term stood at Rs.397.32 Lakh compared to Rs.411.34 Lakh for the previous year showing nominal fall of over 3% in the current fiscal. The fall in the profit was largely due to change in the product mix and fall in the revenues of high profitably jointing kits and OFC accessories to Solar Systems and new product SMPS Systems.

Factors affecting Financial Performance

- 1. Unusual or infrequent events or transactions.** There have been no events, to the best of our knowledge, other than as described in this Red Herring Prospectus, which may be called "unusual" or "infrequent". Unusual events like war, natural calamities or breakdown of world economic order and disasters like flood, water shortage, disease etc., can affect the company's operations temporarily, however, the application is hosted at the customer site with back up for disaster recovery. Our own development centres have a back up and recovery plan. As they may be hosted and managed through the Internet, the company's operations can be re-established in a week through remote management.
- 2. Significant economic/regulatory changes.** There have been no significant changes in the laws governing the Telecom and Energy Industry in the recent past. The economic changes that can affect the company are changes in tax laws.
- 3. Known trends or Uncertainties.** The major part of the Company's business is in the Telecom and Energy Sectors domain. There is no unusual or infrequent event or transaction that can materially affect these businesses. The business is unlikely to witness wild fluctuations or to be materially affected by economic changes. They do not affect income from continuing operations in a significant manner. The economic changes that can affect the company are only changes in tax laws. Other than as described in this Red Herring Prospectus, to our knowledge, there are no known trends or uncertainties that have or had or are expected to have a materially adverse impact on revenue or income of the Company from continuing operations.
- 4. Future relationship between costs and income in case of events such as future increase in labour or material costs or prices that will cause a material changes are known:** The Company is continuously working to create efficient processes resulting in cost reduction and have a better control over its activities. Other than as described in this red Herring Prospectus, to our knowledge, there are no known factors, which will affect the future relationship between the costs and income, or which will have a material impact on the operations and finances of the Company.
- 5. Seasonality of business.** The business of the company is not seasonal. However there are significant variations in the quarterly revenues and profits because of various factors like general economic conditions, festivals and financial year-ends.
- 6. Increase in Sales and Revenue.** The increases in net sales or revenue are due to increased sales volume, introduction of new products or services or increased sales prices. The Company has steadily grown over a period of time and as such the company is able to isolate itself from increase in material cost or decrease in sales volume.



7. The size of Industry segments in which the company operates has been appropriately explained.
8. **Competitive conditions.** The business environment for Telecom Industry has changed since 1994 through National Telecom Policy. Currently, there are fewer, but more serious, players in the market. The Company maintains its competitiveness through innovative service / product offerings at attractive prices.

The Directors confirm that there have been no events or circumstances since the date of the last financial statements as disclosed in the prospectus which materially or adversely affect or is likely affect the trading or profitability of the company, or the value of its assets, or its ability to pay liabilities within next twelve months.

The Directors confirm that there have been no events or circumstances since the date of the last financial statements as disclosed in the prospectus which materially or adversely affect or is likely affect the trading or profitability of the company, or the value of its assets, or its ability to pay liabilities within next twelve months.



SECTION VI : LEGAL AND OTHER INFORMATION

OUTSTANDING LITIGATION AND MATERIAL DEVELOPMENTS

1. Cases filed by the Company;

XL Telecom Limited vs. State of Maharashtra

The Company has filed a writ petition no. 9843 of 2004 in the Hon'ble High Court of Judicature at Bombay in the year 2004 against the State of Maharashtra questioning the State powers to regulate and control the Indian Alcohol or Ethanol after denaturalization or rectified spirit. Also whether the provisions of Bombay Denatured Spirit Rules, 1959 in respect of transport, export, import or dehydration of denatured spirit are applicable. The case is yet to come up for hearing.

2. Cases filed against the Company

INCOME TAX PROCEEDINGS AGAINST THE COMPANY AND ITS PROMOTERS

Income Tax authorities under the provisions of Section 132 of the Income Tax Act, 1961 carried out a search during the month of Sep 2005, at the premises of Company, the Promoters. During the course of search the Company and Promoters have admitted certain undisclosed income; the final assessment would impact on the profits of the company to the extent of not provided for in the books.

The company was subject to search under section 132 of Income Tax Act 1961 and the company has made certain admissions which have been admitted by the Income Tax department. The Company has filed the Block Assessment return in respect of the above matter. The company has already provided for Rs.365 Lakh of Income Tax payable as on 30th June 2005, which covers the Income Tax payable for disclosers even. There is no future impact of Tax Liability in respect of the search proceedings.

INCOME TAX PROCEEDINGS AGAINST THE GROUP COMPANY, SOFTPROJEX (I) LIMITED

The Group Company has been part of the overall search of Income Tax Authorities under the provisions of section 132. However, since the Company being 100% EOU, there is no liability arrived by the IT Authorities

Apart from the above there are no cases filed against the Company by the third parties.



3. Cases Against the Director of the Company

The following are the list of cases filed against one of the Director Shri Ashok Kumar Goyal who was formerly working as Director and Company Secretary in Xerox ModiCorp Limited and M/s. Indian Management Advisors & Leasing (P) Limited:

Case No.	Cases Filed by	Court	Charges / Allegations	Present Status
709/2003	ROC, Kanpur	Spl Chief Judicial Magistrate- Meerut	Non compliance of of the provisions of Sec-211 read with Schedule VI of the Companies Act	The matter is Compounded by Regional Director, Northern Region under section 621-A of the Companies Act, 1956 (Matter yet to be withdrawn)
710 /2003	ROC, Kanpur	Spl Chief Judicial Magistrate- Meerut	Non compliance of of the provisions of Sec-193(1) of the Companies Act	The matter is Compounded by Regional Director, Northern Region under section 621-A of the Companies Act, 1956 (Matter yet to be withdrawn)
711/2003	ROC, Kanpur	Spl Chief Judicial Magistrate-Meerut	Non compliance of of the provisions of Sec-209 (1) of the Companies Act, 1956.	The matter is Compounded by Regional Director, Northern Region under section 621-A of the Companies Act, 1956 (Matter yet to be withdrawn)
499/2004	DCIT, Circle 9(1), New Delhi	Additional Chief Metropolitan Magistrate, Tis Hazari Courts, New Delhi	Claim of Depreciation in lease transaction disputed by department	Proceedings are still pending.
41/1994	ITO, Spl Range 24, New Delhi	Additional Chief Metropolitan Magistrate, Tis Hazari Courts, New Delhi	Claim of Depreciation in lease transaction disputed by the Department of Income Tax	Proceedings have been stayed by the Hon'ble High Court of Delhi

There has been no litigation, dispute after filing Draft Red Herring Prospectus with the SEBI.



Material Developments since the Last Balance Sheet date:

- The Company has participated in the Maharashtra Tender for supply of Ethanol for a period of 3 years ending 31.10.2009 and has been positioned itself as L1 Bidder and become eligible to receive orders of 450 Lakh Its each for the year 2007-08 and 2008-09 and 262.50 Lakh Its for the period 1.4.2009 to 31.10.2009 as per Tender conditions.
- The Company has received a Firm Purchase Order from Forta Imports and Exports S.L. for supply of 66,667 Solar Photovoltaic Modules of 180 Wp.totalling 12 MW and valued Euro 42 Million equivalent to Rs.22050 Lakh to be supplied between July 2007 to Dec 2009.
- The Company has received a Pilot Order for supply of Fixed Wireless Phones to Reliance Infocom, country's Private CDMA Operator valued over Rs.578.50 Lakh.

Other than what is mentioned above there are no material developments which have occurred since the date of last financial statements disclosed (i.e. 30th June 2006) in this Red Herring Prospectus. The Board of Directors are not aware of any such circumstances that materially or adversely affects or are likely to affect the profitability of the company.



GOVERNMENT APPROVALS/ LICENSING ARRANGEMENTS

The Company has received all the necessary licenses, permissions and approvals from the Central and State Governments and other government agencies/certification bodies required for its business and no further approvals are required by the company for carrying on the present as well as proposed business activities of the Company. It must, however, be distinctly understood that in granting the above approvals, the Government/RBI and other authorities do not take any responsibility for the financial soundness of the Company or for the correctness of any of the statements or any commitments made or opinions expressed in this Red Herring Prospectus.

In view of the approvals listed below, our Company can undertake this Issue and its current business activities.

Corporate Approvals

SI No.	Issuing Authority	Registration / License Number	Nature of Registration
1.	Registrar of Companies	01- 05844 Dt. 03.10.1985	Certificate of Incorporation Changed its name u/s. 21 of Companies Act, 1956 to XL Telecom Private Limited on 18.12.1985 Subsequently changed its name to XL Telecom Limited on 31.12.1990
	Department of Company Affairs, Ministry of Company Affairs	Dt. 01.12.2004	Under Section 269, 198(4) /309(3) & 637AA of the Companies Act, 1956 for the re-appointment and payment of remuneration to our Managing Director for the period of three years.
2.	Income Tax Department	AAACX 0113C Dt. 03.10.1985	Permanent Account Number
	Income Tax Department	-	TAN
3.	Central Excise Assistant Commissioner Central Excise & Customs, Nanded	AAACX0113CXM003 Dt. 02.04.2004	Manufacturing of Excise Goods
	Ministry of Finance Department of Revenue, Central Excise, Mallapur, Hyderabad	AAACX0113C XM 001 Dt. 31.03.2003	Manufacturing of Excisable Goods
	Cherlapally, Hyderabad Ministry of Finance , Department of Revenue for the manufacture at 198/A&B, Phase – II, IDA, Cheriapally, Hyderabad.	AAACX0113CXM002 Dt. 09.01.2002	
	Service Tax Ministry of Finance, Department of Revenue, Deputy Commissioner of Service Tax, Chennai – II Division.	MRS/CHENNAI- II/1836 / STC Dt. 18.05.2005	Certificate of Registration, Form-ST-2, for providing services of Maintenance and Repair
	Office of the Commissioner of Central Excise and Customs Service Tax Cell, Hyderabad Commissionerate	A/c Head for Tax- 00440245A/c Head for Other Dues00440246	Allotment of Service Tax Code Number for providing Maintenance or Repair Service.
	Office of the Superintendent of Customs & Central Excise Service Tax Cell: Hyderabad – II Commissionerate	AAACX0113CST002 Dt. 28.09.2004	Certificate of Registration U/s. 69 of the Finance Act, 1994, for providing Maintenance or Repairs Services.



SI No.	Issuing Authority	Registration / License Number	Nature of Registration
	Government of India Ministry of Finance (Department of Revenue), Office of the Deputy Commissioner of Central Excise, Service Tax, Chanigarh	AAACXC113CST004 Dt. 15.06.2005	Certificate of Registration under Service Tax Rules for providing Maintenance & Repair Service.
4.	Sales Tax (i) Sales Tax Department	0763892 Dt. 19.01.2004	For carrying on the business in Ethanol Alcohol
	(ii) Commercial Tax Department, Secunderabd	PIT/02/1/1089/1986-19 Dt. 01.05.1986	
	(iii) Mallapur Hyderabad	PJT/02/58/44/90-91	
	Sales Tax Department, Maharashtra	431710/8/479 Dt. 19.01.2004	Manufacturing in Ethanol Alcohol & Servicing centre for Mobile Hand Sets.
	Commercial Tax Officer Mylapore, Assessment Circle, Chennai	TNGST NO. 0702285, 2004-2005. Dt. 02.09.2004	Principal place of business
	Commercial Tax Officer Mylapore Assessment Circle	CST NO. 838519 Dt. 11.08.2004	For sales and servicing of Spare Parts of CDMA Phones
	Office of the Deputy Commissioner of Commercial Taxes Patliputra Circle, Patna	10050349063 Dt. 07.10.2005	Certificate of Registration U/s. 19 of the Bihar Value Added Tax Ordinance, 2005
	Office of the Sales Tax Officer	073302884 Dt. 21.07.2004	
	Sales Tax Department of Jaipur, Rajasthan	08052109693 Dt. 26.09.2005	ST – 4, Sales Tax Registration , to deal with purchase and sale of Mobile Phone, Mobile Accessories, Power Supply Equipment and Accessories, SMPS, Parts & Accessories.
	Bombay Sales Tax, Nanded	431710/S/479 (Duplicate) Dt. 19.01.2004	Manufacture in Ethanol Alcohol & Service Centre for Mobile Hand Sets, Sales & Servicing of (Spare parts of) SMPS Power Plants, CDMA Mobile phones
	Department of Commercial Taxes, Third Circle, Thiruvananthapuram	TIN 32010818174 Dt. 09.09.2005	Branch place of business for Sales and Servicing of CDMA Phones , SMPS, Power Plants, Accessories, Spare Parts
	Central Sales Tax, Thiruvananthapuram, Kerala	0108C 181740 Dt. 09.09.2005	Sales and Servicing of CDMA Phones, SMPS, Power Plant, Accessories and Spare Parts.
	Assistant Commissioner of Commercial Taxes, West Bengal	19674059048 Dt. 22.07.2005	Certificate of Registration, Under The West Bengal Value Added Tax Rules for Cellular Phone and Spare Parts for principal place of business at Prafulla Kanan Kolkata.
	Office of the Deputy Commissioner of Commercial Tax, Kolkata, West Bengal	19674059242 Dt. 22.07.2005	Certificate of Registratoin, Form – B , Under the Central Sales Tax Act.



SI No.	Issuing Authority	Registration / License Number	Nature of Registration
	Sales Tax Department, Solan, Himachal Pradesh	SOL –III- 9535 Dt. 15.10.2005	Certificate of Registration, VAT-IV, for Trading of CDMA Mobile phones & its accessories and parts, SMPS systems and its accessories and parts in Solan
	Central Sales Tax, Solan, Himachal Pradesh	SOL- CST – 9573 Dt. 15.10.2005	Certificate of Registration ST-II for Trading of CDMA Mobile Phones & its accessories and parts, SMPS systems and its accessories and parts
	Central Sales Tax Department, Nanded, Kusanoor, Maharashtra.	431710/C/315 Dt. 19.01.2004	Certificate of Registration, Form – B, under the Central Sales Tax (Registration and Turnover) Rules, 1957 for sale of Ethanol Alcohol & Servicing Centre for Mobile Hand Sets and Sale & Servicing of (spare parts of) SMPS power plants
	Sales Tax Department, Nanded	431710/S/479 Dt. 19.01.2004	Form -2, Certificate of Registration U/s. 22/22A of the Bombay Sales Tax Act for manufacture of Ethanol Alcohol & Servicing Centre for Mobile Hand Sets, Sales & Servicing of (spare parts) of SMPS Power Plants.
	Sales Tax Department Chandigarh	CHA 23612 Dt. 03.08.2005	Certificate of Registration, Form - IV under the Chandigarh Sales Tax Act.
	Sales Tax Department Chandigarh	CHA. CST 23411 Dt. 03.08.2005	Certificate of Registration Form – B for resale of Mobile Phones, SMPS Power Plants and Accessories & parts of Electronic Items
	A.P. General Sales Tax, Secunderabad.	PJT/02/5B/44/90-91 Dt. 27.08.1990	Certificate of Registration and Manufacture U/s. 5-B, of the A.P. General Sales Tax Act Commercial Tax Officer, Secunderabad
	Govt. of NCT of Delhi, Department of Sales Tax.	LC/100/07620286475/0305	
5.	Environment(Pollution Control Board)		
	(i) Maharashtra Pollution Control Board	BO/ROA. ABAD-07/04/E/CC - 23 Dt. 20.01.2004	Consent to establish u/s. 25 of the Water (Prevention & Control of Pollution) Act, 1974, U/s. 21 of the Air(Prevention & Control of Pollution) Act, 1981 and Authorisation / Renewal of Authorisation under Rule 5 of the Hazardous Wastes (Management & Handling) Rules, 1989
	(ii) Maharashtra Pollution Control Board	BO/ROA/ Nanded/ 148-04/O/CC-164 Dt. 11.11.2004	Consent to operate under Section 26 of the Water (Prevention & Control of Pollution) Act, 1974 & under Section 21 of the Air (Prevention & Control of Pollution) Act, 1981 and Authorisation/ Renewal of Authorisation under rule Rule -5 of the Hazardous Wastes (Mangement & Handling) Rules 1989 and Amendment Rules, 2003 from Maharashtra Pollution Control Board,



SI No.	Issuing Authority	Registration / License	Nature of Registration
6.	Telecommunication Engineering Centre, Central Region, Cherlapally, Hyderabad	TBHD/IA.XLT.005/2004-TECDt. 15.09.2004	Location for manufacturing of granules, profile and Thermo Shrink Sleeve units.
7.	Government Approvals		
	Bharat Sanchar Nigam Limited Bangalore	TSEC/HD/SMP-01/04/019. MAR 2005Dt: 31.03.2005	Technical Specification Evaluation Certificate
	Government of India, Telecommunication Engineering Centre, New Delhi. (Department of Telecommunication)	TEC/CR/T/CJM-01/02/125. SEP 04Dt. 01.09.2004	Type Approval Certificate, Mallapur, Hyderabad
	Telecommunication Engineering Centre, Central Region, Hyderabad	TBHD/IA.XLT.005/2004 -TECDt. 19.07.2004	Infrastructure Assessment Advice Mallapur, Hyderabad
	Government of India, Telecommunication Engineering Centre, New Delhi. (Department of Telecommunication)	TEC/CR/T/SMP-01/04/172. AUG 04Dt. 10.08.2004	Type Approval Certificate, Cherlapally, Hyderabad SMPS based Power Plant (Category: 4B)
	Government of India, Telecommunication Engineering Centre, New Delhi. (Department of Telecommunication)	TEC/CR/T/SMP-01/04/165. APR 04Dt. 10.08.2004	Type Approval Certificate, Cherlapally, Hyderabad SMPS based Power Plant (Category: 3B)
	Government of India, Telecommunication Engineering Centre, New Delhi. (Department of Telecommunication)	TEC/CR/T/SMP-01/04. APR 04Dt. 27.04.2004	Type Approval Certificate, Cherlapally, Hyderabad SMPS based Power Plant, FR/ FC Module Rating 50V-25Amps.
	Government of India, Telecommunication Engineering Centre, New Delhi. (Department of Telecommunication)	TEC/CR/T/SPV-03/01/002. FEB 04Dt. 19.02.2004	Type Approval Certificate, Mallapur, Hyderabad 12 V solar Photo Voltaic Power Supply for Remote Terminals
	Government of India, Telecommunication Engineering Centre, New Delhi. (Department of Telecommunication)	TEC/CR/T /TMI-01/01/017. AUG 02Dt. 27.08.2002	Type Approval Certificate, Cherlapally, Hyderabad Remote Station (Subscriber Terminal – Handheld type with voice & Data only) For CDMA Digital wireless Local Loop system
	APIIC – Industrial Area Local Authority, KAPRA NOTIFIED MUNICIPAL INDUSTRIAL AREAS SERVICE SOCIETY, NACHARAM	APIIC-LALA/KAPRA/93/2002 Dt. 10.06.2002	Permission for construction of building.
	Ministry of Commerce and Industry, Secretariat for Industrial Assistance.	Acknowledgements	
	Inspector of Factories, Ranga Reddy Circle – II	37429	License to work a Factory
	Ministry of Commerce, Office of the Director General of Foreign Trade, Sultan Bazar, Koti, Hyderabad	0988001624 Dt. 04.05.1988	Certificate of Import Exporter Code. (IEC)



SECTION VII: OTHER REGULATORY AND STATUTORY DISCLOSURES

Authority for the Issue

The issue of Equity Shares in this Issue by the Company has been authorised by the resolution of the Board of Directors passed at their meeting held on January 27, 2006, subject to the approval of shareholders through a special resolution to be passed pursuant to Section 81(1A) of the Companies Act. The shareholders approved the Issue at the Extra-ordinary General Meeting of the shareholders of the Company held on February 23, 2006.

Prohibition by SEBI

Our Company, our Directors, our Promoters, Directors or the person(s) in control of our Promoters, our affiliates and companies with which our Directors are associated with as directors, have not been prohibited from accessing or operating in capital markets under any order or direction passed by SEBI.

Further, our Promoters or their relatives have confirmed that they have not been detained as willful defaulters by the RBI or any other government authority and there are no violations of securities laws committed by them in the past or are pending against them. Our Company or entities of our Group do not appear on the RBI defaulter list, nor are there any violations of securities laws committed by them in the past or pending against them.

Eligibility of the issuer company

As per clause 2.2.1 of SEBI (DIP) Guidelines an unlisted company may make an initial public offering (IPO) of equity shares or any other security, which may be converted into or exchanged with equity shares at a later date, only if it meets all the following conditions:

- (a) The company has net tangible assets of at least Rs. 300 Lakhs in each of the preceding 3 full years (of 12 months each), of which not more than 50% is held in monetary assets:
Provided that if more than 50% of the net tangible assets are held in monetary assets, the company has made firm commitments to deploy such excess monetary assets in its business/project;
- (b) The company has a track record of distributable profits in terms of Section 205 of the Companies Act, 1956, for at least three (3) out of immediately preceding five (5) years;
Provided further that extraordinary items shall not be considered for calculating distributable profits in terms of Section 205 of Companies Act, 1956;
- (c) The company has a net worth of at least Rs. 100 Lakhs in each of the preceding 3 full years (of 12 months each);
- (d) In case the company has changed its name within the last one year, atleast 50% of the revenue for the preceding 1 full year is earned by the company from the activity suggested by the new name; and
- (e) The aggregate of the proposed issue and all previous issues made in the same financial year in terms of size (i.e., offer through Offer document + firm allotment + promoters' contribution through the offer document), does not exceed five (5) times its pre-issue networth as per the audited balance sheet of the last financial year.

The details of Distributable Profits, Net Tangible Assets and Net worth of the Company are as follows:-

(Rs in Lakhs)

Particulars	30 th June, 2005	30 th June, 2004	30 th June, 2003	30 th June, 2002	30 th June, 2001
Networth	2950.03	2242.57	1774.64	1623.61	1245.34
Net Tangible Assets*	834.21	1020.86	399.68	557.99	444.86
Distributable Profits	594.05	449.93	(50.97)	378.28	276.84
Monetary Assets. **	2950.03	2242.57	1774.64	1623.61	1245.34

(*) Net tangible assets is defined as the sum of field assets (including capital work in progress and excluding revaluation reserves), trade investments, current assets (excluding deferred tax assets) less current liabilities (excluding deferred tax liabilities and long term liabilities)

(**) Monetary assets include cash on hand and bank and quoted investments including units in open ended mutual fund schemes at cost, net of provisions for diminution in value



In addition, we shall ensure that the number of allottees getting Equity Shares is not less than one thousand in number.

Disclaimer Clause

AS REQUIRED, A COPY OF THE RED HERRING PROSPECTUS HAS BEEN SUBMITTED TO SEBI. IT IS TO BE DISTINCTLY UNDERSTOOD THAT SUBMISSION OF THE RED HERRING PROSPECTUS TO SEBI SHOULD NOT, IN ANY WAY, BE DEEMED OR CONSTRUED THAT THE SAME HAS BEEN CLEARED OR APPROVED BY THE SEBI. SEBI DOES NOT TAKE ANY RESPONSIBILITY EITHER FOR THE FINANCIAL SOUNDNESS OF ANY SCHEME OR THE PROJECT FOR WHICH THE ISSUE IS PROPOSED TO BE MADE OR FOR THE CORRECTNESS OF THE STATEMENTS MADE OR OPINIONS EXPRESSED IN THE RED HERRING PROSPECTUS. THE BOOK RUNNING LEAD MANAGERS VIZ., ANAND RATHI SECURITIES LIMITED AND CENTRUM CAPITAL LIMITED HAVE CERTIFIED THAT THE DISCLOSURES MADE IN THE RED HERRING PROSPECTUS ARE GENERALLY ADEQUATE AND ARE IN CONFORMITY WITH SEBI (DISCLOSURE AND INVESTOR PROTECTION) GUIDELINES, 2000 IN FORCE FOR THE TIME BEING. THIS REQUIREMENT IS TO FACILITATE INVESTORS TO TAKE AN INFORMED DECISION FOR MAKING AN INVESTMENT IN THE PROPOSED ISSUE. IT SHOULD ALSO BE CLEARLY UNDERSTOOD THAT WHILE THE COMPANY IS PRIMARILY RESPONSIBLE FOR THE CORRECTNESS, ADEQUACY AND DISCLOSURE OF ALL RELEVANT INFORMATION IN THE RED HERRING PROSPECTUS, THE BOOK RUNNING LEAD MANAGERS ARE EXPECTED TO EXERCISE DUE DILIGENCE TO ENSURE THAT THE COMPANY DISCHARGES ITS RESPONSIBILITY ADEQUATELY IN THIS BEHALF AND TOWARDS THIS PURPOSE, THE BOOK RUNNING LEAD MANAGERS VIZ., ANAND RATHI SECURITIES LIMITED AND CENTRUM CAPITAL LIMITED HAVE FURNISHED TO SEBI, A DUE DILIGENCE CERTIFICATE DATED MAY 11, 2006 IN ACCORDANCE WITH THE SEBI (MERCHANT BANKERS) REGULATIONS, 1992 WHICH READS AS FOLLOWS:

“1. WE HAVE EXAMINED VARIOUS DOCUMENTS INCLUDING THOSE RELATING TO LITIGATION LIKE COMMERCIAL DISPUTES, PATENT DISPUTES, DISPUTES WITH COLLABORATORS ETC. AND OTHER MATERIALS IN CONNECTION WITH THE FINALISATION OF THE DRAFT RED HERRING PROSPECTUS PERTAINING TO THE SAID ISSUE.

2. ON THE BASIS OF SUCH EXAMINATION AND DISCUSSIONS WITH THE COMPANY, ITS DIRECTORS AND OTHER OFFICERS, OTHER AGENCIES, INDEPENDENT VERIFICATION OF THE STATEMENTS CONCERNING THE OBJECTS OF THE ISSUE, PROJECTED PROFITABILITY, PRICE JUSTIFICATION AND THE CONTENTS OF THE DOCUMENTS MENTIONED IN THE ANNEXURE AND OTHER PAPERS FURNISHED BY THE COMPANY.

WE CONFIRM THAT:

- (A) THE DRAFT RED HERRING PROSPECTUS FORWARDED TO SEBI IS IN CONFORMITY WITH THE DOCUMENTS, MATERIALS AND PAPERS RELEVANT TO THE ISSUE;**
- (B) ALL THE LEGAL REQUIREMENTS CONNECTED WITH THE SAID ISSUE AS ALSO THE GUIDELINES, INSTRUCTIONS, ETC. ISSUED BY SEBI, THE GOVERNMENT AND ANY OTHER COMPETENT AUTHORITY IN THIS BEHALF HAVE BEEN DULY COMPLIED WITH; AND**
- (C) THE DISCLOSURES MADE IN THE DRAFT RED HERRING PROSPECTUS ARE TRUE, FAIR AND ADEQUATE TO ENABLE THE INVESTORS TO MAKE A WELL INFORMED DECISION AS TO THE INVESTMENT IN THE PROPOSED ISSUE.**

WE CONFIRM THAT BESIDES OURSELVES, ALL THE INTERMEDIARIES NAMED IN THE DRAFT RED HERRING PROSPECTUS ARE REGISTERED WITH SEBI AND THAT TILL DATE SUCH REGISTRATIONS ARE VALID.

WHEN UNDERWRITTEN, WE SHALL SATISFY OURSELVES ABOUT THE NET WORTH OF THE UNDERWRITERS TO FULFIL THEIR UNDERWRITING COMMITMENTS.

WE CERTIFY THAT WRITTEN CONSENT FROM THE PROMOTERS HAS BEEN OBTAINED FOR INCLUSION OF THEIR SECURITIES AS PART OF PROMOTER'S CONTRIBUTION SUBJECT TO LOCK-IN AND THE SECURITIES PROPOSED TO FORM PART OF PROMOTERS CONTRIBUTION SUBJECT TO LOCK-IN WILL NOT BE DISPOSED/SOLD/TRANSFERRED BY THE PROMOTERS DURING THE PERIOD STARTING FROM THE DATE OF FILING THE DRAFT RED HERRING PROSPECTUS WITH SEBI TILL THE DATE OF COMMENCEMENT OF LOCK-IN PERIOD AS STATED IN THE DRAFT RED HERRING PROSPECTUS.

ALL LEGAL REQUIREMENTS PERTAINING TO THE ISSUE HAVE BEEN COMPLIED WITH AT THE TIME OF FILING OF THE DRAFT RED HERRING PROSPECTUS WITH THE ROC IN TERMS OF SECTION 60B OF THE ACT. ALL LEGAL REQUIREMENTS PERTAINING TO THE ISSUE WOULD BE COMPLIED WITH AT THE TIME OF REGISTRATION OF THE FINAL PROSPECTUS WITH THE ROC IN TERMS OF SECTION 56, SECTION 60 AND SECTION 60B OF THE COMPANIES ACT.”



THE FILING OF THE RED HERRING PROSPECTUS DOES NOT, HOWEVER, ABSOLVE THE COMPANY FROM ANY LIABILITIES UNDER SECTION 63 AND SECTION 68 OF THE ACT OR FROM THE REQUIREMENT OF OBTAINING SUCH STATUTORY AND OTHER CLEARANCES AS MAY BE REQUIRED FOR THE PURPOSE OF THE PROPOSED ISSUE. SEBI FURTHER RESERVES THE RIGHT TO TAKE UP AT ANY POINT OF TIME, WITH THE BOOK RUNNING LEAD MANAGERS, ANY IRREGULARITIES OR LAPSES IN THE RED HERRING PROSPECTUS.

General Disclaimer

The Company, the Directors and the BRLMs accepts no responsibility for statements made otherwise than in the Red Herring Prospectus or in the advertisements or any other material issued by or at instance of the above mentioned entities and anyone placing reliance on any other source of information, including our website, www.xltelecom.net, would be doing so at his or her own risk.

The BRLMS accept no responsibility, save to the limited extent as provided in the Underwriting Agreement to be entered into among the Underwriters and the Company and the Memorandum of Understanding among the BRLMs and the Company dated May 10th, 2006.

All information shall be made available by us and the BRLMS to the public and investors at large and no selective or additional information would be available for a section of the investors in any manner whatsoever including at road show presentations, in research or sales reports or at bidding centres, etc.

We shall not be liable to the Bidders for any failure in downloading the Bids due to faults in any software/hardware system or otherwise.

Further, the Company and the BRLMs undertake to update the Red Herring Prospectus and keep the public informed of any material changes till the listing and trading commencement.

Disclaimer in Respect of Jurisdiction

The Issue is being made in India to persons resident in India (including Indian nationals resident in India who are majors, HUFs, companies, corporate bodies and societies registered under the applicable laws in India and authorized to invest in shares, Indian mutual funds registered with SEBI, Indian financial institutions, commercial banks, regional rural banks, co-operative banks (subject to RBI permission), Trusts registered under the Societies Registration Act, 1860, as amended from time to time, or any other Trust law and who are authorized under their constitution to hold and invest in shares) and to NRIs, FIIs and Foreign Venture Capital Funds registered with SEBI. The Red Herring Prospectus does not, however, constitute an offer to sell or an invitation to subscribe to shares offered hereby in any other jurisdiction to any person to whom it is unlawful to make an offer or invitation in such jurisdiction. Any person into whose possession the Red Herring Prospectus comes is required to inform him or herself about and to observe any such restrictions. Any dispute arising out of the Issue will be subject to the jurisdiction of appropriate court(s) in Hyderabad only.

No action has been or will be taken to permit a public offering in any jurisdiction where action would be required for that purpose, except that the Draft Red Herring Prospectus has been filed with SEBI for observations and SEBI has given its observations and the Red Herring Prospectus has been filed with the RoC as per the provisions of the Companies Act. Accordingly, the Equity Shares, represented thereby may not be offered or sold, directly or indirectly, and the Red Herring Prospectus may not be distributed, in any jurisdiction, except in accordance with the legal requirements applicable in such jurisdiction. Neither the delivery of the Red Herring Prospectus nor any sale hereunder shall, under any circumstances, create any implication that there has been no change in our affairs from the date hereof or that the information contained herein is correct as of any time subsequent to this date.

Disclaimer Clause of the National Stock Exchange of India Limited

As required, a copy of the Red Herring Prospectus has been submitted to the National Stock Exchange of India Limited ("NSE"). NSE has vide its letter No. NSE/LIST/26259-J dated July 24, 2006 which was valid upto October 23, 2006 and further extension obtained vide letter No. NSE/LIST/32416-4 dated November 3, 2006, given permission to the Company to use the Exchange's name in the Red Herring Prospectus as one of the stock exchanges on which this Company's securities are proposed to be listed subject to the Company fulfilling the various criteria for listing including the one related to paid up capital and market capitalization (i.e. the paid up capital shall not be less than Rs. 10 crores and market capitalization shall not be less than Rs. 25 crores at the time of listing). The NSE has scrutinized the Draft Red Herring Prospectus for its limited internal purpose of deciding on the matter of granting the aforesaid permission to this Company. It is to be distinctly understood that the aforesaid permission given by NSE should not in any way be deemed or construed that the Draft Red Herring Prospectus has been cleared or approved by NSE; nor does it in any manner warrant, certify or endorse the correctness or completeness of any of the contents of the Red Herring Prospectus; nor does it warrant that this Company's securities will be listed or will continue to be listed on the NSE; nor does it take any responsibility for the financial or other soundness of the Issuer, its promoters, its management or any scheme or project of this Company.



Every person who desires to apply for or otherwise acquire any securities of this Company may do so pursuant to independent inquiry, investigation and analysis and shall not have any claim against the Exchange whatsoever by reason of any loss which may be suffered by such person consequent to or in connection with such subscription/acquisition whether by reason of anything stated or omitted to be stated herein or any other reason whatsoever.

Disclaimer Clause of the Bombay Stock Exchange Limited

The Bombay Stock Exchange Limited (“BSE”) has vide its letter no. DCS/Smd/sm/2006 dated July 03, 2006, given permission to the Company to use the BSE’s name in the Red Herring Prospectus as one of the stock exchanges on which this Company’s securities are proposed to be listed. The BSE has scrutinized the Draft Red Herring Prospectus for its limited internal purpose of deciding on the matter of granting the aforesaid permission to this Company. The BSE does not in any manner:-

- (i) warrant, certify or endorse the correctness or completeness of any of the contents of the Red Herring Prospectus; or
- (ii) warrant that this Company’s securities will be listed or will continue to be listed on the Exchange; or
- (iii) take any responsibility for the financial or other soundness of this Company, its promoters, its management or any scheme or project of this Company;

and it should not for any reason be deemed or construed that the Red Herring Prospectus has been cleared or approved by the BSE. Every person who desires to apply for or otherwise acquires any securities of this Company may do so pursuant to independent inquiry, investigation and analysis and shall not have any claim against BSE whatsoever by reason of any loss which may be suffered by such person consequent to or in connection with such subscription/acquisition whether by reason of anything stated or omitted to be stated herein or for any other reason whatsoever.

Undertaking from the Promoters and Directors

The Company accepts full responsibility for the accuracy of the information given in the Red Herring Prospectus and confirms that to the best of their knowledge and belief, there are no other facts, their omission of which make any statement in the Red Herring Prospectus misleading and they further confirm that they have made all reasonable inquiries to ascertain such facts. The Company further declares that the Stock Exchanges to which an application for official quotation is proposed to be made do not take any responsibility for the financial soundness of the Issue or for the price at which the Equity Shares are offered or for the correctness of the statement made or opinions expressed in the Red Herring Prospectus. The Promoters/Directors declare and confirm that no information/material likely to have a bearing on the decision of investors in respect of the Equity Shares offered in terms of the Red Herring Prospectus has been suppressed, withheld and/or incorporated in the manner that would amount to misstatement, misrepresentation and in the event of its transpiring at any point of time till allotment/refund, as the case may be, that any information/material has been suppressed /withheld and/or amounts to a misstatement/misrepresentation, the Promoters/Directors undertake to refund the entire application monies to all the subscribers within 7 days thereafter without prejudice to the provisions of Section 63 of the Companies Act.

Filing

A copy of the Red Herring Prospectus along with the documents required to be filed under section 60 B of the Companies Act will be delivered for registration to the ROC, Andhra Pradesh at Hyderabad. A copy of the Red Herring Prospectus required to be filed under section 60 of the Companies Act would be delivered for Registration with the ROC, having attached thereto the Material Contracts and Documents for Inspection referred in section titled “ Material Contracts and Documents” on page 167 of the Red Herring Prospectus.

A copy of the Draft Red Herring Prospectus has been filed with SEBI at Ground Floor, Mittal Court, “A” Wing, Nariman Point, Mumbai 400 021.

Listing

Applications have been made to BSE and NSE for permission to deal in and for an official quotation of the Equity Shares of the Company. If the permission to deal in and for an official quotation of the Equity Shares is not granted by either of the Stock Exchanges mentioned above, the Company shall forthwith repay, without interest, all moneys received from the applicants in pursuance of the Red Herring Prospectus. If such money is not repaid within eight days after the Company becomes liable to repay it (i.e. from the date of refusal or within 70 days from the date of Issue Closing Date, whichever is earlier), then the Company shall, on and from expiry of eight days, be liable to repay the money, with interest at the rate of 15% per annum on application money, as prescribed under Section 73 of the Companies Act. Provided however, that where such refusal results from the fraud or wilful default or negligence of the Company, the Company shall be liable to pay the interest on the application money as per Section 73 of the Companies Act.



The Company shall ensure that all steps for the completion of the necessary formalities for listing and commencement of trading at both the Stock Exchanges mentioned above are taken within seven working days of finalization and adoption of the basis of allocation for the Issue.

Consents

The written consents of Promoters, Directors, Company Secretary, Auditors, Legal Advisors, Book Running Lead Managers, Registrars to the Issue, Bankers to the Company, Bankers to the Issue, Syndicate Member(s) and Escrow Collection Bank(s) to act in their respective capacities, have been obtained and filed along with a copy of the Red Herring Prospectus with the Registrar of Companies, Andhra Pradesh at Hyderabad as required under Section 60 of the Act and such consents have not been withdrawn up to the time of delivery of the Red Herring Prospectus for registration with Registrar of Companies.

Expert Opinion

Our Company has not obtained any other expert opinion.

Expenses of the Issue

The expenses of the Issue payable by the Company inclusive of brokerage, fees payable to the BRLMS, Registrar to the Issue, Legal Advisors, stamp duty, printing, publication, advertising and distribution expenses, bank charges, listing fees and other miscellaneous expenses will not exceed Rs. [●] and will be met out of the proceeds of the Issue.

Details of Fees Payable

Particulars	Rs in Lakh	As % of Total Issue Expenses	As % of Total Issue Size
Lead Management Fees, Brokerage, Underwriting & Selling Commission*	[●]	[●]	[●]
Fees payable to Registrar	[●]	[●]	[●]
Fees payable to Legal Advisors	[●]	[●]	[●]
Fees payable to Auditors	[●]	[●]	[●]
Advertising and Marketing expenses	[●]	[●]	[●]
Printing Stationery & Postage	[●]	[●]	[●]
Others expenses	[●]	[●]	[●]
Total Estimated Issue expenses	[●]	[●]	[●]

* Will be incorporated after finalisation of Issue Price

Fees Payable to the Book Running Lead Managers, Underwriting Commission, Brokerage and Selling Commission:

The total fees payable to the BRLMs including brokerage and selling commission for the Issue will be as per the Memorandum of Understanding executed between the Company and the BRLMS dated May 10, 2006 a copy of which are available for inspection at the Registered Office of the Company. Underwriting commission shall be paid as set out in the Syndicate Agreement based on the Issue price.

Fees Payable to the Registrar to the Issue

The fees payable to the Registrar to the Issue will be as per the Registrar' Memorandum of Understanding dated April 13, 2006 copies of which is available for inspection at the Registered Office of the Company.

Adequate funds will be provided to the Registrar to the Issue to enable them to send refund orders or allotment advice by registered post.

Previous Public or Rights Issues

This is the first public issue of the Company. We have not made any public issue previously.

Previous Issue of Shares Otherwise than for Cash

The Company has not issued any shares for consideration other than for cash except as mentioned in the section titled "Capital Structure" on page 15 of this Red Herring Prospectus.



Commission or Brokerage on Previous Issues

Except as stated in the Red Herring Prospectus, no sum has been paid or is payable as commission or brokerage for subscribing to or procuring or agreeing to procure subscription for any of the Equity Shares of the Company.

Particulars in Regard to the Company and Other Listed Companies under the Same Management within the meaning of Section 370(1)(B) of the Companies Act, 1956, which made any Capital Issue during last three years.

There are no listed companies under the same management within the meaning of section 370 (1)(B) of the Companies Act that made any capital issue during the last three years.

Promises Vs Performance

The company has not made any public issue of shares since its incorporation. There are no group company, which has made any public issues.

Outstanding Bonds/ Debentures

There are no outstanding debentures or bonds or redeemable preference shares or any other instruments issued by the issuer company outstanding as on the date of Red Herring Prospectus.

Stock Market Data

This being the first public issue by the Company, no stock market data is available.

Disclosure on Investor Grievances and Redressal System

The Company will settle investor grievances expeditiously and satisfactorily. The agreement between the Company and the Registrar will provide for retention of records with the Registrar for a period of one year from the last date of dispatch of Letters of Allotment/Share Certificates/Refund Orders to enable the investors to approach the Registrar for redressal of their grievances.

All grievances relating to the Issue may be addressed to the Registrar to the Issue, Bigshare Services Private Limited, giving full details such as name, address of the applicant, number of Shares applied for, amount paid on application and the bank branch/collection center where the application was submitted.

Disposal of Investor Grievances

The average time required by the Company/Registrar for the redressal of routine investor grievances shall be seven working days from the date of receipt of the complaint. In case of non-routine complaints and where external agencies are involved, the Company/Registrar would strive to redress these complaints as expeditiously as possible.

Investors can also contact the Compliance Officer for any investor grievances at the following contact details:

Ms. Ch. Bhavani
335, Chandralok Complex,
Sarojini Devi Road,
Secunderabad - 500003

Changes in the Auditors during the last Three Years and Reasons thereof

There have been no changes in the auditors of the Company during past three years.

Capitalization of Reserves or Profits during the Last Five Years

During the years 1989, 1991 and 2006, the Company has issued Bonus Shares out of Free Reserves, details of which are given as under::

Date of allotment/ fully Paid Up	No. of Shares	Face Value (Rs.)	Nominal Value (Rs.)	Cumulative Paid-up Capital (Rs.)	Remarks
16-09-1989	27544	100	2754400	2754400	3 shares for every 5 shares
19-01-1991	31181	100	3118100	5872500	2 shares for every 5 shares
03-03-2006	4771596	10	47715960	95431920	1 Share for every 1 Share held

Revaluation of Assets during the last Five Years

The Company has not revalued its assets during the last five years.



SECTION VIII

ISSUE RELATED INFORMATION

Terms of the Issue

The Equity Shares being issued are subject to the provisions of the Companies Act, Securities Contracts (Regulation) Act, 1956, Securities Contracts (Regulation) Rules, 1957, the Memorandum and Articles of the Company, the terms of the Red Herring Prospectus, Bid-cum-Application Form, the Revision Form, the Confirmation of Allocation Note (“CAN”) and other terms and conditions as may be incorporated in the allocation advices, and other documents/certificates that may be executed in respect of the Issue. The Equity Shares shall also be subject to laws as applicable, guidelines, notifications and regulations relating to the issue of capital and listing and trading of securities issued from time to time by SEBI, Government of India, Stock Exchanges, RBI, RoC and/or other authorities, as in force on the date of the Issue and to the extent applicable.

Authority for the Issue

The Issue has been authorized pursuant to a resolution of the Board of Directors of the Company adopted at its meeting held on 27th January 2006 and by a special resolution adopted pursuant to Section 81(1A) of the Companies Act at the Extra Ordinary General Meeting of the Company held on 23rd Feb 2006.

Ranking of Equity Shares

The Equity Shares to be issued shall be subject to the Companies Act, 1956, provisions of Memorandum and Articles of Association and shall rank *pari passu* with the existing Equity Shares of our Company in all respects including rights in respect of dividend, voting rights or any other corporate benefits, if any, declared by our Company after the date of Allotment.

Face Value and Price Band

The Equity Shares is with a face value of Rs. 10 each. The Equity shares are being offered in the price band of Rs. 125 and Rs. 150. The issue price is 12.5 times the face value at lower end of the price band and 15 times of the face value at the higher end of the price band.

Compliance with SEBI Guidelines

The Company shall comply with all disclosure and accounting norms as specified by SEBI from time to time.

Rights of the Equity Shareholders

Subject to applicable laws, the equity shareholders have the following rights:

- Right to receive dividend, if declared;
- Right to attend general meetings and exercise voting powers, unless prohibited by law;
- Right to vote on a poll either in person or by proxy;
- Right to receive offers for rights shares and be allotted bonus shares, if announced;
- Right to receive surplus on liquidation;
- Right of free transferability; and
- Such other rights, as may be available to a shareholder of a public company under the Companies Act and Memorandum and Articles of Association of the Company.

For a detailed description of the main provisions of the Company’s Articles of Association dealing with voting rights, dividend, forfeiture and lien, transfer and transmission and/or consolidation/splitting, kindly refer to the section titled “Main Provisions of Articles of Association” on page 151 of the Red Herring Prospectus.

Market Lot

In terms of Section 68B of the Companies Act, the Equity Shares of our Company shall be allotted only in dematerialised form. As per existing SEBI Guidelines, the trading of our Equity Shares shall only be in dematerialised form.

Since the trading of the Equity Shares is compulsorily in dematerialised mode, the tradable lot is one equity share. Allocation of Equity Shares through the Issue will be done only in electronic form to the successful bidders, subject to a minimum of 45 Equity Shares. For details of allocation and allotment, see “Other Regulatory and Statutory Disclosure – Basis of Allotment or Allocation” on page 147 of the Red Herring Prospectus.



Jurisdiction

Exclusive jurisdiction for the purpose of the Issue is with competent courts/authorities in Hyderabad, India.

Nomination Facility to the Investor

In accordance with Section 109A of the Companies Act, the sole or first bidder, along with other joint bidders, may nominate any one person in whom, in the event of the death of sole bidder or in case of joint bidders, death of all the bidders, as the case may be, the Equity Shares transferred, if any, shall vest. A person, being a nominee, entitled to the Equity Shares by reason of the death of the original holder(s), shall in accordance with Section 109A of the Companies Act, be entitled to the same advantages to which he or she would be entitled if he or she were the registered holder of the equity share(s). Where the nominee is a minor, the holder(s) may make a nomination to appoint, in the prescribed manner, any person to become entitled to Equity Shares in the event of his/her death during the minority. A nomination shall stand rescinded upon a sale / transfer / alienation of Equity Shares by the person nominating. A buyer will be entitled to make a fresh nomination in the manner prescribed. Fresh nomination can be made only on the prescribed form available on request at our Registered Office or to the registrar and transfer agents of our Company.

In accordance with section 109B of the Companies Act, any person, who becomes a nominee by the virtue of the provisions of section 109A of the Companies Act, shall upon production of such evidence as may be required by Board, elect either:

- to register himself / herself as the holder of the Equity Shares; or
- to make such transfer of the Equity shares as the deceased holder could have made.

Further, the Board may at any time give notice requiring any nominee to choose either to be registered himself or herself or to transfer the Equity Shares, and if the notice is not complied with within a period of ninety days, the Board may thereafter withhold payment of all dividends, bonuses or other monies payable in respect of the Equity Shares, until the requirements of the notice have been complied with.

Notwithstanding anything stated above, since the allotment of Equity Shares in the Issue will be made only in dematerialised mode, there is no need to make a separate nomination with the Company. Nominations registered with respective depository participant of the applicant would prevail. If the investors require changing the nomination, they are requested to inform their respective depository participant.

Impersonation

Attention of the applicants is specifically drawn to the provisions of sub-section (1) of Section 68 A of the Companies Act, which is reproduced below:

“Any person who:

- (a) makes in a fictitious name, an application to a company for acquiring or subscribing for, any shares therein, or**
- (b) otherwise induces a company to allot, or register any transfer of shares therein to him, or any other person in a fictitious name**

shall be punishable with imprisonment for a term which may extend to five years.”

Minimum Subscription

If we do not receive the minimum subscription of 90% of the Net Issue to the Public including devolvement of Underwriters, if any, within 60 days from the date of closure of the Issue, the Company shall forthwith refund the entire subscription amount received. If there is a delay beyond eight days after the Company becomes liable to pay the amount we shall pay interest as per section 73 of Companies Act.

Withdrawal of the Issue

The Company in consultation with the BRLMS, reserves the right not to proceed with the Issue after the bidding. In case the Company decides so, it shall issue a public notice within two days of the closure of the bidding, indicating the reasons for withdrawal of the Issue in the newspapers in which the bid advertisement appeared earlier. The Company shall also inform the Stock Exchanges on which the Equity Shares were proposed to be listed.

Arrangements for Disposal of Odd Lots

The Company's shares will be traded in dematerialized form only and therefore the marketable lot is one (1) share. Therefore there is no possibility of odd lots.



Restriction on Transfer and Transmission of Shares/Debentures on their Consolidation/Splitting

Nothing contained in the Articles of Association of the Company shall prejudice any power of the Company to refuse to register the transfer of any share.

No fee shall be charged for sub-division and consolidation of share certificates (physical form), debenture certificates and detachable warrants and for sub-division of letters of allotment and split, consideration, renewal and pucca transfer receipts into denomination corresponding to the market units of trading.

Application by Non Residents/NRIs/FIIs

It is to be distinctly understood that there is no reservation for any non-residents, eligible NRIs, FIIs, Foreign Venture Capital investors registered with SEBI and Multilateral and Bilateral Development Financial Institutions and such applicants shall be treated on the same basis with other categories for the purpose of allocation. The Allotment of Equity Shares to such persons shall be subject to the conditions as may be prescribed by the Government of India, Ministry of Finance and Company Affairs Department (Department of Economic Affairs) and the RBI while granting such permissions.

As per Notification No. FEMA/20/2000-RB dated May 3, 2000, as amended from time to time, under automatic route of the Reserve Bank, the Company is not required to make an application for Issue of Equity Shares to NRIs/FIIs with repatriation benefits. However, the allotment/transfer of the Equity shares to NRIs/FIIs shall be subject to the prevailing RBI Guidelines. Sale proceeds of such investments in equity shares will be allowed to be repatriated along with the income thereon subject to the permission of the RBI and subject to the Indian tax laws and regulations and any other applicable laws.

As per the policy of the RBI, Overseas Corporate Bodies cannot participate in the Issue.

Bid/Issue Programme

Bidding Period / Issue Period

BID / ISSUE OPENS ON	MONDAY, DECEMBER 4, 2006
BID / ISSUE CLOSES ON	THURSDAY, DECEMBER 7, 2006

Bids and any revision in Bids shall be accepted **only between 10 a.m. and 3 p.m.** (Indian Standard Time) during the Bidding Period/Issue Period as mentioned above at the bidding centers mentioned on the Bid cum Application Form except that on the Bid Closing Date, the Bids shall be accepted **only between 10 a.m. and 1 p.m.** (Indian Standard Time) and uploaded till such time as permitted by the BSE and NSE.

The Price Band will be decided by us in consultation with the BRLMs and advertised one day prior to the Bid Opening Date/ Issue Opening Date in an English language newspaper of wide circulation, a Hindi language newspaper of wide circulation and a regional language newspaper of wide circulation, including any revisions thereof.

The Company reserves the right to revise the Price Band during the Bidding Period/Issue Period in accordance with SEBI Guidelines. The cap on the Price Band should not be more than 20% of the floor of the Price Band. Subject to compliance with the immediately preceding sentence, the floor of the Price Band can move up or down to the extent of 20% of the floor of the Price Band disclosed in the Red Herring Prospectus.

In case of a revision in the Price Band, the Bidding Period/Issue Period will be extended for three additional days after revision of Price Band subject to the Bidding Period/Issue Period not exceeding 10 working days. Any revision in the Price Band and the revised Bidding Period/Issue Period, if applicable, will be widely disseminated by notification to BSE and NSE by issuing a press release, and also by indicating the change on the websites of the BRLMS and at the terminals of the Syndicate.



SECTION IX: ISSUE STRUCTURE

Public Issue of 39,56,808 Equity Shares of Rs. 10/- each at the Issue Price of Rs. [●] for cash aggregating Rs. [●] Lakh. Out of this 1,76,808 Equity Shares are reserved for allocation to Employees of the Company. The Net Issue to Public is 37,80,000 Equity Shares. The Issue is being made through a 100% book building process. Details of the Issue structure are tabulated below:

	Reserved portion for Employees of the Company	QIBs	Non-Institutional Bidders	Retail Individual Bidders
Number of Equity Shares	Up to 1,76,808 Equity Shares	Upto 18,90,000 Equity Shares or Issue size less allocation to Non-Institutional Bidders and Retail Individual Bidders	Minimum of 5,67,000 Equity Shares or Issue size less allocation to QIBs and Retail Individual Bidders	Minimum of 13,23,000 Equity Shares or Issue size less allocation to QIBs and Non-Institutional Bidders
Percentage of Issue size available for Allocation	Up to 4.68 % of the Issue size	Not more than 50 % of Net Issue to Public. 5% of the QIB portion shall be available for allocation to Mutual Funds. Mutual Funds participating in the 5% reservation in the QIB portion will also be eligible in the remaining QIB portion. The unsubscribed portion in the Mutual Fund reservation will be available to QIBs.	Minimum 15 % of Net Issue to Public or Issue size less allocation to QIBs and Retail Individual Bidders	Minimum 35% of Net Issue to Public or Issue size less allocation to QIBs and Non-Institutional Bidders
Basis of Allocation if respective category is oversubscribed	Proportionate	Proportionate a. 94,500 Equity shares shall be allocated on a proportionate basis to Mutual Funds; and b. 17,95,500 Equity shares shall be allocated on a proportionate basis to all QIBs including Mutual Funds receiving allocations as per a. above.	Proportionate	Proportionate
Minimum Bid	45 Equity Shares and thereafter in multiples of 45 Equity Shares	Such number of Equity Shares that the Bid Amount exceeds Rs. 1,00,000/- and in multiples of 45 Equity Shares	Such number of Equity Shares that the Bid Amount exceeds Rs. 1,00,000 and in multiples of 45 Equity Shares	45 Equity Shares and thereafter in multiples of 45 Equity Shares
Maximum Bid	Such number of Equity Shares that the number of Equity Shares Bid for should not exceed 1,76,808 Equity Shares	Such number of Equity Shares that the Bid Amount exceeds Rs. 1,00,000 and in multiples of 45 Equity Shares, not exceeding the Issue size subject to applicable regulations	Such number of Equity Shares that the Bid Amount exceeds Rs. 1,00,000 and in multiples of 45 Equity Shares, not exceeding the Issue size	Such number of Equity Shares so as to ensure that the Bid Amount does not exceed Rs. 1,00,000



	Reserved portion for Employees of the Company	QIBs	Non-Institutional Bidders	Retail Individual Bidders
Mode of Allotment	Compulsory in Dematerialised form	Compulsory in Dematerialised form	Compulsory in Dematerialised form	Compulsory in Dematerialised form
Trading Lot	One	One	One	One
Size of allocation	Minimum of 45 Equity Shares and in multiples of one Equity Share thereafter	Minimum of 45 Equity Shares and in multiples of one Equity Share thereafter	Minimum of 45 Equity Shares and in multiples of one Equity Share thereafter	Minimum of 45 Equity Shares and in multiples of one Equity Share thereafter
Who can Apply	Eligible Employees who are permanent employees of our Company; or a Director of our Company (whether a whole-time Director, part time Director or otherwise); an Employee should be an Indian national, based in India and physically present in India on the date of submission of the Bid-cum-Application Form. Also, such person should be an Employee on the payroll of the Company on the date of filing the Red Herring Prospectus with SEBI. Promoter Directors are not permitted to participate in this category.	Public financial institutions, as specified in section 4A of the Companies Act, scheduled commercial banks, mutual funds, foreign institutional investors registered with SEBI, multilateral and bi-lateral development financial institutions, venture capital funds registered with SEBI, Foreign Venture Capital Investors registered with SEBI, State Industrial Development Corporations, Insurance companies registered with Insurance Regulatory and Development Authority (IRDA), Provident Funds (with minimum corpus of Rs. 2500 Lakh and Pension Funds with minimum corpus of Rs. 2500 Lakh who are authorized under their constitution to hold and invest in Equity Shares	Resident Indian individuals, HUF (in the name of Karta), companies, corporate bodies, NRIs, societies and trusts	Individuals (including NRIs and HUFs) applying for up to Rs. 1,00,000
Terms of Payment	Margin Amount applicable to reserved portion for Employees of the Company at the time of submission of Bid-cum-Application Form to the members of the Syndicate	Margin Amount applicable to QIB Bidders at the time of submission of Bid-cum-Application Form to the members of the Syndicate	Margin Amount applicable to Non-Institutional Bidders at the time of submission of Bid-cum-application Form to the members of the Syndicate	Margin Amount applicable to Retail Bidders at the time of submission of Bid cum Application Form to the members of the Syndicate
Margin Amount	Full Bid Amount on Bidding	At least 10% of the Full Bid Amount on Bidding	Full Bid Amount on Bidding	Full Bid Amount on Bidding

Notes:

1. The unsubscribed portion, if any, in the employee reservation portion will be added back to the Net Issue to Public and will be considered for allotment only on a proportionate basis.
2. Subject to valid Bids being received at or above the Issue Price. Under subscription, if any, in the Retail Individual Investors, Non-institutional Investors or QIBs portion would be allowed to be met with spill over from any other category at the sole discretion of the Company and the BRLMs subject to applicable provisions of SEBI Guidelines.
3. In case the Bid Cum Application Form is submitted in joint names, the investors should ensure that the demat account is also held in the same joint names and in the same sequence in which they appear in the Bid Cum Application Form.



SECTION X: ISSUE PROCEDURE

Book Building Procedure

The Issue is being made through the 100% Book Building Process wherein upto 50% of the Net Issue to Public shall be available for allocation to QIBs on a proportionate basis, out of which 5% shall be available for allocation on a proportionate basis to Mutual Funds only. Further, not less than 35% of the Net Issue to Public shall be available for allocation on a proportionate basis to Retail Individual Bidders and not less than 15% of the Net Issue to Public shall be available for allocation on a proportionate basis to Non-Institutional Bidders, subject to valid Bids being received at or above the Issue Price. Employee reservation portion shall not be considered for the purpose of determining the issue price through Book Building Process.

Bidders are required to submit their Bids through the members of the Syndicate. We, in consultation with the BRLMs reserve the right to reject any QIB Bid procured by any or all members of the Syndicate provided the rejection is at the time of receipt of such Bid and the reason for rejection of the Bid is communicated to the Bidder at the time of rejection of the Bid. In case of Non-Institutional Bidders and Retail Individual Bidders, the Company would have a right to reject the Bids only on technical grounds.

Investors should note that Equity Shares will be allotted to successful Bidders only in the dematerialized form. Bidders will not have the option of getting allotment of the Equity Shares in physical form. The Equity Shares on allotment shall be traded only in the dematerialised segment of the Stock Exchanges.

Illustration of Book Building and Price Discovery Process (*Investors should note that the following is solely for the purpose of illustration and is not specific to this Issue*)

Bidders can bid at any price within the price band. For instance, assuming a price band of Rs. 20 to Rs. 24 per share, issue size of 3,000 equity shares and receipt of five bids from bidders out of which one bidder has bid for 500 shares at Rs.24 per share while another has bid for 1,500 shares at Rs.22 per share. A graphical representation of the consolidated demand and price would be made available at the bidding centers during the bidding period. The illustrative book as shown below shows the demand for the shares of our Company at various prices and is collated from bids from various investors.

Number of equity shares Bid for	Bid Price (Rs.)	Cumulative equity shares Bid for	Subscription
500	24	500	16.67%
1000	23	1500	50.00%
1500	22	3000	100.00%
2000	21	5000	166.67%
2500	20	7500	250.00%

The price discovery is a function of demand at various prices. The highest price at which the issuer is able to issue the desired quantum of shares is the price at which the book cuts off i.e., Rs. 22 in the above example. The issuer, in consultation with the BRLMs will finalise the issue price at or below such cut off price i.e. at or below Rs. 22. All bids at or above this issue price and cut-off bids are valid bids and are considered for allocation in respective category.

Bid-cum-Application Form

Bidders shall only use the specified Bid-cum-Application Form bearing the stamp of a member of the Syndicate for the purpose of making a Bid in terms of this Red Herring Prospectus. The Bidder shall have the option to make a maximum of three Bids in the Bid-cum-Application Form and such options shall not be considered as multiple bids. Upon the allocation of Equity Shares, dispatch of the Confirmation of Allocation Note ("CAN"), and filing of the Prospectus with the Registrar of Companies, Andhra Pradesh at Hyderabad, the Bid-cum-Application Form shall be considered as the Application Form. Upon completing and submitting the Bid-cum-Application Form to a member of the Syndicate, the Bidder is deemed to have authorised the Company to make the necessary changes in this Red Herring Prospectus and the Bid-cum-Application Form as would be required for filing the Prospectus with the Registrar of Companies, Andhra Pradesh at Hyderabad and as would be required by Registrar of Companies, Andhra Pradesh at Hyderabad after such filing, without prior or subsequent notice of such changes to the Bidder.



The prescribed colour of the Bid-cum-Application Form for various categories is as follows:

Category	Colour of Bid-cum-Application Form
Indian public or NRI applying on a non-repatriation basis	White
Non-residents, NRIs, FIIs, Foreign Venture Capital Fund registered with SEBI, Multilateral and Bilateral Development Financial Institutions applying on repatriation basis	Blue
Eligible Employees	Pink

Who can Bid

1. Indian nationals resident in India who are majors, in single or joint names (not more than three);
2. Hindu Undivided Families or HUFs in the individual name of the Karta. The Bidder should specify that the Bid is being made in the name of the HUF in the Bid-cum-Application Form as follows: "Name of sole or first Bidder: XYZ Hindu Undivided Family applying through XYZ, where XYZ is the name of the Karta". Bids by HUFs would be considered at par with those from individuals;
3. Companies, corporate bodies and societies registered under the applicable laws in India and authorised to invest in the Equity Shares;
4. Indian Mutual Funds registered with SEBI;
5. Indian Financial Institutions, commercial banks (excluding foreign banks), regional rural banks, co-operative banks (subject to RBI regulations, as applicable);
6. Venture Capital Funds registered with SEBI;
7. Foreign Venture Capital Investors registered with SEBI;
8. State Industrial Development Corporations;
9. Multilateral and bilateral development financial institutions;
10. Eligible NRIs and other Non Residents including FIIs on a repatriation basis or non-repatriation basis subject to applicable laws; and
11. Insurance companies registered with the Insurance Regulatory and Development Authority;
12. Provident funds with minimum corpus of Rs. 2500 lakh and who are authorised under their constitution to hold and invest in Equity Shares;
13. Pension funds with minimum corpus of Rs. 2500 lakh and who are authorised under their constitution to hold and invest in Equity Shares;
14. Trust/ society registered under the Societies Registration Act, 1860, as amended, or under any other law relating to trusts/ society and who are authorised under their constitution to hold and invest in Equity Shares; and
15. Scientific and/ or industrial research organizations authorised to invest in Equity Shares.

Note: The members of the Syndicate and any associate of the members of the Syndicate (except asset management companies on behalf of mutual funds, Indian financial institutions and public sector banks) cannot participate in that portion of the Issue where allocation is proportionate and will not be eligible as a QIB in this Issue. Further, the BRLMS and the Syndicate Members shall not be entitled to subscribe to this Issue in any manner except towards fulfilling their underwriting obligation.

As per existing regulations, OCBs cannot Bid in this Issue.

Bidders are advised to ensure that any single Bid from them does not exceed the investment limits or maximum number of Equity Shares that can be held by them under the relevant regulations or statutory guidelines.

Option to Subscribe

Equity Shares being issued through this Red Herring Prospectus can be applied for in the dematerlised form only. Bidders will not have the option of getting the allotment in physical form. The Equity Shares on allotment shall be traded only in the dematerlised segment of the Stock Exchanges.



How to Apply – availability of forms, Red Herring Prospectus and mode of payment

APPLICATION BY MUTUAL FUNDS

As per the current regulations, the following restrictions are applicable for investments by Mutual Funds:

No mutual fund scheme shall invest more than 10% of its net asset value in the Equity Shares or equity related instruments of any company provided that the limit of 10% shall not be applicable for investments in index funds or sector or industry specific funds. No Mutual Fund under its scheme should own more than 10% of any company's paid-up capital carrying voting rights. These limits would have to be adhered to by the mutual funds for investment in the Equity Shares.

In case of a mutual fund, a separate Bid can be made in respect of each scheme of the mutual fund registered with SEBI and such Bids in respect of more than one scheme of the mutual fund will not be treated as multiple Bids provided that the Bids clearly indicate the scheme concerned for which the Bid has been made.

Under the SEBI Guidelines, 5% of the QIB portion has been specially reserved for Mutual Funds.

APPLICATION OF NRIs

Bid cum Application forms has been made available for NRIs at the Registered office of the Company.

NRI applicants may please note that only such applications as are accompanied by payment in free foreign exchange shall be considered for allotment under the NRI category. The NRIs who intend to make payment through Non-Resident Ordinary (NRO) Account shall use the form meant for Resident Indians (white in colour). All instruments accompanying bids shall be payable in Mumbai only.

APPLICATION BY FIIs

As per current regulations, the following restrictions are applicable for investment by FIIs:

No single FII can hold more than 10% of the post-issue paid-up capital of the Company (i.e. 10% of 1,45,00,000 Equity Shares of Rs. 10 each). In respect of an FII investing in the Equity Shares of the Company on behalf of its sub-accounts, the investment on behalf of each sub-account shall not exceed 10% of the total issued capital or 5% of the total issued capital of the company in case such sub-account is a foreign corporate or an individual.

As of now, the aggregate FII holding in the company cannot exceed 24% of the total issued capital of the Company, With the approval of the Board of Directors and the shareholders by way of a special resolution, the aggregate FII holding can go up to 100%. However, as on this date no such resolution has been recommended to the shareholders of the Company for adoption.

Bids by NRIs or FIIs on Repatriation Basis

Bids and revision to bids must be made:

- o On the bid-cum-application form or revision form, as applicable (Blue in colour), and completed in full in BLOCK LETTERS in ENGLISH in accordance with the instructions contained therein.
- o In a single or joint names (not more than three).
- o Bids by NRIs for a Bid amount of up to less than Rs. 1,00,000 would be considered under the Retail Individual Bidders Portion for the purpose of allocation and Bids for a Bid amount of more than or equal to Rs. 1,00,000 would be considered under Non-Institutional Bidder Portion for the purposes of allocation; by FIIs or Foreign Venture Capital Fund, Multilateral and Bilateral Development Financial Institutions for a minimum of such number of Equity Shares and in multiples of 45 Equity Shares thereafter so that the Bid amount exceeds Rs. 1,00,000; for details, please refer to the sub-section titled "Maximum and Minimum Bid Size" in section titled "Issue Procedure" beginning on page 132 of this Red Herring Prospectus.
- o In the names of individuals or in the names of FIIs or in the names of Foreign Venture Capital Fund, Multilateral and Bilateral Development Financial Institutions but not in the names of minors, firms or partnerships, foreign nationals or their nominees or OCB's.
- o Refunds, dividends and other distributions, if any, will be payable in Indian Rupees only and net of bank charges and / or commission. In case of Bidders who remit money payable upon submission of the Bid cum Application Form or Revision Form through Indian Rupee drafts purchased abroad, such payments in Indian Rupees will be converted into US Dollars or any other freely convertible currency as may be permitted by the RBI at the rate of exchange prevailing at the time of remittance and will be dispatched by registered post/speed post or if the Bidders so desire, will be credited to their NRE accounts, details of which should be furnished in the space provided for this purpose in the Bid cum Application Form. Our Company will not be responsible for loss, if any, incurred by the Bidder on account of conversion of foreign currency.



APPLICATION BY SEBI REGISTERED VENTURE CAPITAL FUNDS AND FOREIGN VENTURE CAPITAL INVESTORS

As per the current regulations, the following restrictions are applicable for investments by SEBI registered Venture Capital Funds and Foreign Venture Capital Investors:

The SEBI (Venture Capital) Regulations, 1996 and the SEBI (Foreign Venture Capital Investor) Regulations, 2000 prescribe investment restrictions on venture capital funds and foreign venture capital investors registered with SEBI. Accordingly, the holding by any individual venture capital fund or foreign venture capital investor registered with SEBI should not exceed 25% of the corpus of the venture capital fund/ foreign venture capital investor. The aggregate holdings of venture capital funds and foreign venture capital investors registered with SEBI could, however, go up to 100% of our Company's paid-up equity capital.

The above information is given for the benefit of the Bidders. Our Company and the BRLMs are not liable for any amendments or modification or changes in applicable laws or regulations, which may happen after the date of this Red Herring Prospectus. Bidders are advised to make their independent investigations and ensure that the number of Equity Shares bid for do not exceed the applicable limits under laws or regulations, and our Company and the BRLMs shall on no grounds whatsoever be liable for or responsible for any breach of applicable regulations by any investor or category of investors.

Maximum and Minimum Bid Size

- (a) **For Retail Individual Bidders:** The Bid must be for a minimum of 45 Equity Shares and in multiples of 45 Equity Shares thereafter, subject to maximum Bid amount of Rs. 1,00,000. In case of revision of Bids, the Retail Bidders have to ensure that the Bid Amount does not exceed Rs. 1,00,000. In case the maximum Bid amount is more than Rs. 100,000 due to revision of the Bid or revision of price band or on exercise of the option, then the same would be considered for allocation under the Non-Institutional Bidders category. The Cut-off option is given only to the Retail Individual Bidders indicating their agreement to bid and purchase at the final Issue Price as determined at the end of the Book Building Process.
- (b) **For Other Bidders (Non-Institutional Bidders and QIBs Bidders):** The Bid must be for a minimum of such Equity Shares such that the Bid Amount exceeds Rs. 1,00,000 and in multiples of 45 Equity Shares thereafter. A Bid cannot be submitted for more than the size of the Issue. However, the maximum Bid by a QIB should not exceed the investment limits prescribed for them by the regulatory or statutory authorities governing them. Under existing SEBI guidelines, a QIB Bidder cannot withdraw its Bid after the Bid/Issue Closing Date.

In case of revision of bids, the Non Institutional Bidders who are individuals have to ensure that the Bid Amount is greater than Rs. 1,00,000. In case the Bid Amount reduces to Rs. 1,00,000 or less due to a revision in Bids or revision of price band, the same would be considered for allocation under the Retail portion. Non Institutional Bidders and QIB Bidders are not allowed to Bid at 'Cut-Off'.

- (c) **For Employee Reservation Portion:** The Bid must be for a minimum of 45 Equity Shares and in multiple of 45 Equity Shares. The maximum bid in this category cannot exceed 1,76,808 Equity Shares. Bidders in the Employee Reservation Portion applying for a maximum Bid in any of the Bidding Options not exceeding Rs. 100,000 may bid at "Cut-off".

No promoters or persons belonging to the promoter group are part of the employees for whom reservation has been made.

Information for Bidders

- (a) Our Company will file the Red Herring Prospectus with the Registrar of Companies, Andhra Pradesh at Hyderabad atleast 3 days before the bid/ issue opening date.
- (b) The members of the Syndicate will circulate copies of the Red Herring Prospectus along with the Bid-cum-Application Form to potential investors.
- (c) Any investor (who is eligible to invest in our Equity Shares) who would like to obtain the Red Herring Prospectus and/ or the Bid-cum-Application Form can obtain the same from our corporate office or from any of the BRLMs/Syndicate Members.
- (d) Investors who are interested in subscribing for our Company's Equity Shares should approach any of the BRLMs or Syndicate Member or their authorised agent(s) to register their Bid.
- (e) The Bids should be submitted on the prescribed Bid-cum-Application Form only. Bid-cum-Application Forms should bear the stamp of the members of the Syndicate. Bid-cum-Application Forms, which do not bear the stamp of the members of the Syndicate, will be rejected.

Method and Process of Bidding

- a) Our Company and the BRLMs shall declare the Bid/Issue Opening Date, Bid/Issue Closing Date and Price Band at the time of filing the Red Herring Prospectus with Registrar of Companies, Andhra Pradesh at Hyderabad and also publish



the same in one English national daily, and one Hindi national daily. This advertisement shall contain the minimum disclosures as prescribed under Schedule XX-A of the SEBI Guidelines. The BRLMs and Syndicate Members shall accept Bids from the Bidders during the Issue Period in accordance with the terms of the Syndicate Agreement.

- b) The Bidding Period shall be a minimum of three working days and shall not exceed seven working days. In case the Price Band is revised, the revised Price Band and Bidding Period will be published in two national newspapers (one each in English and Hindi) by indicating on the websites of the BRLMs and at the terminals of the members of the Syndicate. The Bidding Period may be extended, if required, by an additional three working days, subject to the total Bidding Period not exceeding 10 working days.
- c) Each Bid-cum-Application Form will give the Bidder the choice to bid for up to three optional prices (for details refer to the paragraph entitled “Bids at Different Price Levels” below on page 133 of this Red Herring Prospectus) and specify the demand (i.e. the number of Equity Shares bid for) in each option. The price and demand options submitted by the Bidder in the Bid-cum-Application Form will be treated as optional demands from the Bidder and will not be cumulated. After determination of the Issue Price, the maximum number of Equity Shares bid for by a Bidder at or above the Issue Price will be considered for allocation and the rest of the Bid(s), irrespective of the Bid Price, will become automatically invalid.
- d) The Bidder cannot bid on another Bid-cum-Application Form after his or her Bids on one Bid-cum-Application Form have been submitted to any member of the Syndicate. Submission of a second Bid-cum-Application Form to either the same or to another member of the Syndicate will be treated as multiple bids and is liable to be rejected either before entering the Bid into the electronic bidding system, or at any point of time prior to the allocation or allotment of Equity Shares in this Issue. However, the Bidder can revise the Bid through the Revision Form, the procedure for which is detailed under the paragraph “Build up of the Book and Revision of Bids” on page 136 this Red Herring Prospectus.
- e) During the Bidding Period, Bidders may approach the members of the Syndicate to submit their Bid. Every member of the Syndicate shall accept Bids from all clients / investors who place orders through them and shall have the right to vet the Bids.
- f) Along with the Bid-cum-Application Form, all Bidders will make payment in the manner described under the paragraph “Payment into Escrow Account” on page 142 of this Red Herring Prospectus.
- g) The Syndicate Member will enter each bid option into the electronic bidding system as a separate Bid and generate a Transaction Registration Slip, (“TRS”), for each price and demand option and give the same to the Bidder. Therefore, a Bidder can receive up to three TRSs for each Bid-cum-Application Form. It is the responsibility of the Bidder to obtain the TRS from the members of the Syndicate.
- h) Investors who are interested in subscribing for our Equity Shares should approach any of the members of the Syndicate or their authorized agent(s) to register their Bid.

Bids at Different Price Levels

- (a) The Price Band has been fixed at Rs. 125 to Rs. 150 per Equity Share of Rs. 10 each, Rs. 125 being the Floor Price and Rs. 150 being the Cap Price. The Bidders can bid at any price with in the Price Band, in multiples of Re 1. In accordance with SEBI Guidelines, the Company in consultation with the BRLMs can revise the Price Band by informing the Stock Exchanges, releasing a press release, disclosure on the website of the members of the Syndicate, if any and notification on the terminal of the members of the Syndicate. In case of a revision in the Price Band, the Issue will be kept open for a period of three additional working days after the revision of the Price Band, subject to the total Bidding Period not exceeding ten working days.
- (b) The Company in consultation with BRLMs can finalise the Issue Price within the Price Band in accordance with this clause, without the prior approval of, or intimation, to the Bidders.
- (c) The Bidders can bid at any price within the Price Band. The Bidder has to bid for the desired number of Equity Shares at a specific price. **Retail Individual may bid at “Cut-off”. However, bidding at “Cut-off” is prohibited for QIB or Non Institutional Bidders and such Bids from QIBs and Non-Institutional Bidders shall be rejected.**
- (d) Retail Individual Bidders, who bid at the Cut-Off agree that they shall purchase the Equity Shares at the Issue price. Retail Individual Bidders bidding at Cut-Off shall submit the Bid-cum-Application form with cheque/ demand draft for the Bid Amount based on the Cap of the Price Band in with the Syndicate Members. In the event the Bid Amount is higher than the subscription amount payable by the Retail Individual Bidders who bid at the Cut-Off Price (i.e. the total number of Equity Shares allocated in the Issue multiplied by the Issue Price), Retail Individual Bidders shall receive the refund of the excess amounts from the respective Refund Account.
- (e) The Price Band can be revised during the Bidding Period in which case the maximum revisions on either side of the Price Band shall not exceed 20% of the Cap Price and the Floor Price disclosed in the Red Herring Prospectus.



- (f) Any revision in the Price Band shall be widely disseminated including by informing the Stock Exchanges, issuing a press release and making available this information on the Bidding terminals.
- (g) In the event of any revision in the Price Band, whether upwards or downwards, the minimum application size shall be within the range of Rs. 5,000 to Rs. 7,000. The Issuer Company in consultation with the BRLMs shall stipulate the minimum application size (in terms of number of shares) falling within the aforesaid range of minimum application value.
- (h) In case of an upward revision in the Price Band announced as above, Retail Individual Bidders, who had bid at Cut Off Price could either (i) revise their Bid or (ii) make additional payment based on the cap of the revised Price Band (such that the total amount i.e. original bid amount plus additional payment does not exceed Rs. 1,00,000, if the bidder wants to continue to bid at Cut-Off Price), with the members of the Syndicate to whom the original Bid was submitted. In case the total amount (i.e. original Bid Amount plus additional payment) exceeds Rs. 100,000, the Bid will be considered for allocation under the Non Institutional category in terms of this Red Herring Prospectus. If, however, the Bidder does not either revise the Bid or make additional payment and the Issue Price is higher than the cap of the Price Band prior to revision, the number of Equity Shares bid for shall be adjusted downwards for the purpose of allocation, such that no additional payment would be required from the Bidder and the Bidder is deemed to have approved such revised Bid at Cut off Price.
- (i) In case of a downward revision in the Price Band, announced as above, Retail Individual Bidders who have bid at Cut Off price could either revise their Bid or the excess amount paid at the time of bidding would be refunded from the Refund Account

Escrow Mechanism

Escrow Account for the Issue:

The Company shall open Escrow Accounts with one or more Escrow Collection Banks in whose favor the Bidders shall make out the cheque or demand draft in respect of his or her Bid and/or revision of the bid. Cheques or demand drafts received for the full Bid amount from Bidders in a certain category would be deposited in the Escrow Account. The monies in the Escrow Accounts shall be maintained by the Escrow Collection Banks for and on behalf of the bidders. The Escrow Collection Banks shall not exercise any lien whatsoever over the monies deposited therein and shall hold the monies therein in trust for the Bidders. On the Designated Date, the Escrow Collection Banks shall transfer the monies from the Escrow Account to the Public Issue Account and the Refund Account with the Bankers to the Issue as per the terms of the Escrow Agreement.

Payments of refunds to the Bidders shall also be made from the Escrow Account as per the terms of the Escrow Agreement and this Red Herring Prospectus.

The Bidders should note that the escrow mechanism is not prescribed by SEBI and has been established as an arrangement between the Escrow Collection Bank(s), our Company, the Registrar to the Issue, BRLMs to facilitate collections from the Bidders.

1. Terms of Payment and Payment into the Escrow Accounts

Each Bidder shall provide the applicable Margin Amount, and shall, with the submission of the Bid cum Application Form draw a cheque or demand draft for the maximum amount of his/her Bid in favour of the Escrow Account of the Escrow Collection Bank(s) (See "Payment into Escrow Account" on page 142) and submit the same to the member of the Syndicate to whom the Bid is being submitted. The Bidder may also provide the applicable Margin Amount by way of an electronic transfer of funds through the RTGS mechanism. Each QIB shall provide their QIB Margin Amount only to a BRLMS. Bid cum Application Forms accompanied by cash/Stockinvest/money order shall not be accepted. The Margin Amount based on the Bid Amount has to be paid at the time of submission of the Bid cum Application Form.

The members of the Syndicate shall deposit the cheque or demand draft with the Escrow Collection Bank(s), which will hold the monies for the benefit of the Bidders until such time as the Designated Date. On the Designated Date, the Escrow Collection Bank(s) shall transfer the funds equivalent to the size of the issue from the Escrow Account, as per the terms of the Escrow Agreement, into the Public Issue Account. The balance amount after transfer to the Public Issue Account, lying credited with Escrow Collection Banks shall be transferred to the Refund Account. On the Designated Date, and not later than 15 days from the Bid / Issue Closing Date, the Escrow Collection Bank(s) shall refund all amount payable to unsuccessful Bidders and also the excess amount paid on bidding, if any, after adjustment for allocation to the Bidders.

Each category of Bidders i.e. QIBs, Non-Institutional Bidders, Employee Reservation Portion and Retail Individual Bidders would be required to pay their applicable Margin Amount at the time of the submission of the Bid-cum-Application Form. The Margin Amount payable by each category of Bidders is mentioned under the heading "Issue Structure" on page 127 of this Red Herring Prospectus and shall be uniform across all the bidders in the same category.



Where the Margin Amount applicable to the Bidder is less than 100% of the Bid Amount, any difference between the amount payable by the Bidder for Equity Shares allocated at the Issue Price and the Margin Amount paid at the time of Bidding, shall be payable by the Bidder no later than the Pay-in-Date, which shall be a minimum period of two days from the date of communication of the allocation list to the members of the Syndicate by the BRLMs. If the payment is not made favoring the Escrow Account within the time stipulated above, the Bid of the Bidder is liable to be cancelled. However, if the applicable margin amount for bidder is 100%, the full amount of payment has to be made at the time of submission of the Bid-Cum-Application Form.

Where the Bidder has been allocated lesser number of Equity Shares than he or she had bid for, the excess amount paid on bidding, if any, after adjustment for allocation, will be refunded to such Bidder in terms of this Red Herring Prospectus.

Electronic Registration of Bids

- (a) The members of the Syndicate will register the Bids using the on-line facilities of NSE and BSE. There will be at least one on-line connectivity in each city, where a Stock Exchange is located in India and where Bids are being accepted.
- (b) NSE and BSE will offer a screen-based facility for registering Bids for the Issue. This facility will be available on the terminals of the Syndicate Member and their authorised agents during the Bidding Period. Syndicate members can also set up facilities for off-line electronic registration of Bids subject to the condition that they will subsequently download the off-line data file into the on-line facilities for book building on a regular basis. On the Bid Closing Date/ Issue Closing Date, the Syndicate Member shall upload the Bids till such time as may be permitted by the Stock Exchanges.
- (c) BSE and NSE will aggregate demand and price for Bids registered on their electronic facilities on a regular basis and display graphically the consolidated demand at various price levels. This information can be accessed on BSE's website at "www.bseindia.com" or on NSE's website at "www.nseindia.com".
- (d) At the time of registering each Bid, the Syndicate members shall enter the following details of the investor in the on-line system:
 - Name of the investor (Investors should ensure that the name given in the Bid cum Application form is exactly the same as the Name in which the Depository Account is held. In case, the Bid cum Application Form is submitted in joint names, investors should ensure that the Depository Account is also held in the same joint names and are in the same sequence in which they appear in the Bid cum Application Form.).
 - Investor Category such as Individual, Corporate or Mutual Fund, etc.
 - Number of Equity Shares bid for
 - Bid price
 - Bid-cum-Application Form number
 - Whether payment is made upon submission of Bid-cum-Application Form
 - Depository Participant Identification Number and Client Identification Number of the demat account of the Bidder
- (e) A system generated TRS will be given to the Bidder as a proof of the registration of each of the Bidding options. **It is the Bidder's responsibility to request and obtain the TRS from the members of the Syndicate.** The registration of the Bid by the Syndicate Member does not guarantee that the Equity Shares shall be allocated either by the Syndicate Member or the Company.
- (f) Such TRS will be non-negotiable and by itself will not create any obligation of any kind.
- (g) Consequently, the members of the Syndicate has also the rights to accept the bid or reject it with out assigning any reasons, in case of QIBs. In case of Non-Institutional Bidders, Employee Reservation Portion and Retail Individual Bidders, Bids would not be rejected except on the technical grounds listed on Page 144 in this Red Herring Prospectus.
- (h) It is to be distinctly understood that the permission given by NSE and BSE to use their network and software of the Online IPO system should not in any way be deemed or construed to mean that the compliance with various statutory and other requirements by our Company, BRLMs are cleared or approved by NSE and BSE; nor does it in any manner warrant, certify or endorse the correctness or completeness of any of the compliance with the statutory and other requirements nor does it take any responsibility for the financial or other soundness of our Company, our Promoters, our management or any scheme or project of our Company.
- (i) It is also to be distinctly understood that the approval given by NSE and BSE should not in any way be deemed or construed that this Red Herring Prospectus has been cleared or approved by the NSE and BSE; nor does it in any manner



warrant, certify or endorse the correctness or completeness of any of the contents of this Red Herring Prospectus; nor does it warrant that the Equity Shares will be listed or will continue to be listed on the NSE and BSE.

Build Up of the Book and Revision of Bids

- (a) Bids registered by various Bidders through the members of the Syndicate shall be electronically transmitted to the NSE or BSE mainframe on a regular basis.
- (b) The book gets built up at various price levels. This information will be available with the BRLMs on a regular basis.
- (c) The Price Band can be revised during the bidding period, in which case the bidding period shall be extended further for a period of three days, subject to the total bidding period not exceeding three working days. The Cap on the price band shall not be more than 20% of the floor of the price band. Subject to compliance with the immediately preceding sentence, the floor of price band can move up or down to the extent of 20% of the floor of the price band disclosed in the red herring prospectus.
- (d) Any revision in the price band will be widely disseminated by informing the Stock Exchanges, by issuing a Public Notice in two national newspapers (one each in English and Hindi) and one local newspaper and also indicating the change on the relevant websites and the terminals of the members of the syndicates.
- (e) During the Bidding Period, any Bidder who has registered his or her interest in the Equity Shares at a particular price level is free to revise his or her Bid within the price band using the printed Revision Form, which is a part of the Bid-cum-Application Form.
- (f) Revisions can be made in both the desired number of Equity Shares and the bid price by using the Revision Form. Apart from mentioning the revised options in the revision form, the Bidder must also mention the details of all the options in his or her Bid-cum-Application Form or earlier Revision Form. For example, if a Bidder has bid for three options in the Bid-cum-Application Form and he is changing only one of the options in the Revision Form, he must still fill the details of the other two options that are not being changed, in the Revision Form. Incomplete or inaccurate Revision Forms will not be accepted by the members of the Syndicate.
- (g) The Bidder can make this revision any number of times during the Bidding Period. However, for any revision(s) of the Bid, the Bidders will have to use the services of the same members of the Syndicate through whom he or she had placed the original Bid. Bidders are advised to retain copies of the blank Revision Form and the revised Bid must be made only in such Revision Form or copies thereof.
- (h) Any revision of the Bid shall be accompanied by payment in the form of cheque or demand draft for the incremental amount, if any, to be paid on account of the upward revision of the Bid. The excess amount, if any, resulting from downward revision of the Bid would be returned to the Bidder at the time of refund in accordance with the terms of this Red Herring Prospectus. In case of QIBs, the members of the Syndicate shall collect the payment in the form of cheque or demand draft or electronic transfer of funds through RTGS for the incremental amount in the QIB margin, if any, to be paid on account of the upward revision of bid at the time of one or more revision by the QIB bidders.
- (i) When a Bidder revises his or her Bid, he or she shall surrender the earlier TRS and get a revised TRS from the Syndicate Member. **It is the responsibility of the Bidder to request for and obtain the revised TRS, which will act as proof of his or her having revised the previous Bid.**
- (j) Only bids that are uploaded to the online IPO system of NSE/ BSE shall be considered for allocation / allotment. In case of discrepancy of data between NSE or BSE and the Syndicate Member, the decision of the BRLMs based on physical records of Bid-cum-Application Forms shall be final and binding to all concerned.

Price Discovery and Allocation

- (a) After the Bid/Issue Closing Date, the BRLMs will analyze the demand generated at various price levels and discuss pricing strategy with us.
- (b) We in consultation with the BRLMs shall finalise the "Issue Price" and the number of Equity Shares to be allotted in each investor category.
- (c) The allocation for QIBs, upto 50% of the Net Issue to Public, of which 5% shall be reserved for Mutual Funds would be proportionate. The allocation to Non-Institutional Bidders and Retail Individual Bidders of not less than 15% and 35% of the Net Issue to Public, respectively, would be on proportionate basis, in consultation with Designated Stock Exchange, subject to valid Bids being received at or above the Issue Price.
- (d) Under subscription, if any, in Non-Institutional and Retail categories would be allowed to be met with spill over from any of the other categories at the discretion of the Company and the BRLMs. However, if the aggregate demand by Mutual



Funds is less than 5% of the QIB Portion, the balance Equity Shares from the portion specifically available for allocation to Mutual Funds in the QIB Portion will first be added to the QIB Portion and be allocated proportionately to the QIB Bidders in proportion to their Bids in accordance with the “Basis of Allotment or Allocation” described on page 147 of this Red Herring Prospectus.

- (e) Any under subscription in equity shares reserved for allocation to eligible employees would be treated as a part of the net issue to public and allocated in accordance with the basis of allotment described in the heading titled “Basis of Allotment or Allocation” on page 147 of this Red Herring Prospectus.
- (f) The BRLMs, in consultation with us, shall notify the Syndicate Member of the Issue Price and allocations to their respective Bidders, where the full Bid Amount has not been collected from the Bidders.
- (g) We reserve the right to cancel the Issue any time after the Bid/Issue Opening Date but before allotment without assigning any reasons whatsoever.
- (h) Allocation to QIBs, Non-residents, FIIs and NRIs applying on repatriation basis will be subject to the terms and conditions stipulated by the RBI while granting permission for allotment of equity shares to them.
- (i) In terms of SEBI Guidelines, QIB Bidders shall not be allowed to withdraw their Bid after the closure of Bidding.

Signing of Underwriting Agreement and RoC Filing

- (a) We, the BRLMs and the Syndicate Members shall enter into an Underwriting Agreement on finalisation of the Issue Price and allocation(s) to the QIB Bidders.
- (b) After signing the Underwriting Agreement, we would update and file the updated Red Herring Prospectus with Registrar of Companies, Andhra Pradesh at Hyderabad, which then would be termed ‘Prospectus’. The Prospectus would have details of the Issue Price, Issue Size, underwriting arrangements and would be complete in all material respects.

Advertisement regarding Issue Price and Red Herring Prospectus

A statutory advertisement will be issued by the Company after the filing of the Red Herring Prospectus with the Registrar of Companies, Andhra Pradesh at Hyderabad in two widely circulated newspapers (one each in English and Hindi) and one local newspaper. This advertisement in addition to the information (in the format and contain the disclosures specified in Part A of Schedule XX-A of the SEBI Guidelines) that has to be set out in the statutory advertisement shall indicate the Issue Price. Any material updates between the date of Red Herring Prospectus and the Prospectus shall be included in the advertisement.

Issuance of Confirmation of Allocation Note

After the determination of Issue Price, the following steps would be taken

- (a) Upon approval of the Basis of Allotment by the Designated Stock Exchange, the BRLMs or Registrar to the Issue shall send to the Syndicate Member a list of their Bidders who have been allocated Equity Shares in the Issue. However, investors should note that the company shall ensure that the demat credit of equity shares pursuant to allotment shall be made on the same date to all the investors in this issue.
- (b) The BRLMs or Syndicate Members would then send the CAN to their Bidders who have been allocated Equity Shares in the Issue. The dispatch of a CAN shall be deemed a valid, binding and irrevocable contract for the Bidder to pay the entire Issue Price for all the Equity Shares allocated to such Bidder. Those QIB Bidders who have not paid the bid amount in full into the Escrow Account at the time of bidding shall pay in full the amount payable into the Escrow Account by the Pay-in Date specified in the CAN.
- (c) Bidders who have been allocated Equity Shares and who have already paid the margin amount for the said equity shares into the Escrow Account at the time of bidding shall directly receive the CAN from the Registrar to the Issue subject, however, to realization of their cheque or demand draft paid into the Escrow Account. The dispatch of a CAN shall be deemed a valid, binding and irrevocable contract for the Bidder to pay the entire Issue Price for all the Equity Shares to be allotted to such Bidder.

Designated Date and Allotment of Equity Shares

- (a) We shall ensure the allotment of Equity Shares is done within 15 days of Bid/Issue Closing Date. After the funds are transferred from the Escrow Account to the Public Issue Account and the refund account on the Designated Date, we would ensure the credit to the successful bidders depositories account of the allotted Equity Shares to the allottees within two working days of the date of allotment. In case we fail to make allotment within 15 days of the Bid/ Issue Closing Date, interest would be paid to the investors @15% p.a.



- (b) All allottees will receive credit for the Equity Shares directly in their depository account. **As per SEBI Guidelines, equity Shares will be issued only in the dematerialized form to the allottees.** Allottees will have the option to re-materialize the Equity Shares so allotted, if they so desire, as per the provisions of the Companies Act and the Depositories Act.
- (c) The Company will ensure that the allotment of Equity Shares is done within 15 days of the Bid Closing Date/Issue Closing Date. After the funds are transferred from the Escrow Account to the Issue Account on the Designated Date, we would ensure the credit to the successful Bidders depository account within two working days of the date of allotment.
- (d) Investors are advised to instruct their Depository Participant to accept the Equity Shares that may be credited to their depository account to them pursuant to allotment in this Issue.

GENERAL INSTRUCTIONS

Do's:

- a) Check if you are eligible to apply;
- b) Complete the Bid-cum-Application Form(White or Blue or Pink in Colour, as the case may be) after reading all the instructions carefully;
- c) Ensure that the details about Depository Participant and beneficiary account are correct as Equity Shares will be allotted in the dematerialized form only;
- d) Ensure that the Bids are submitted at the bidding centers only on forms bearing the stamp of a member of the Syndicate;
- e) Ensure that you have been given a TRS for all your Bid options;
- f) Submit Revised Bids to the same member of the Syndicate through whom the original Bid was placed and obtain a revised TRS;
- g) Ensure that the bid is within price band;
- h) Ensure that DP account is activated;
- i) Investors must ensure that the name given in the Bid-cum-Application Form is exactly the same as the name in which the Depository Account is held. In case, the Bid-cum-Application Form is submitted in joint names, investors should ensure that the Depository Account is also held in the same sequence as they appear in the Bid-cum- Application Form;
- j) If your Bid is for Rs. 50,000 or more, ensure that you mention your PAN allotted under the I.T. Act and ensure that you have attached a copy of your PAN card with the Bid-cum-Application Form. In case the PAN has not been allotted, mention "Not Allotted" in the appropriate place. (See section titled "Issue Procedure – Permanent Account Number" on page 143 of this Red Herring Prospectus).
- k) Ensure that the Demographic Details (as defined herein below) are updated, true and correct in all respects.

Don'ts:

- a) Do not Bid for lower than the minimum Bid size;
- b) Do not Bid/ revise Bid price to less than the lower end of the price band or higher than the higher end of the price band;
- c) Do not Bid on another Bid-cum-Application Form after you have submitted a Bid to the member of the Syndicate;
- d) Do not pay the Bid amount in cash, through stockinvest, by money order or by postal order;
- e) Do not send Bid-cum-Application Forms by post; instead submit the same to members of the Syndicate only;
- f) Do not Bid at cut off price (for QIBs and non-institutional bidders);
- g) Do not fill up the Bid-cum-Application Form such that the Equity Shares bid for exceeds the Issue size and/ or investment limit or maximum number of Equity Shares that can be held under the applicable laws or regulations or maximum amount permissible under the applicable regulations; and

Instructions for Completing the Bid-cum-Application Form

Bidders can obtain Bid-cum-Application Forms and / or Revision Forms from the BRLMs or Syndicate Member.

Bids and Revisions of Bids

Bids and revisions of Bids must be:



- (a) Made only in the prescribed Bid-cum-Application Form or Revision Form, as applicable (white colour for resident Indians and blue for Non-residents including NRIs, FIIs, Foreign Venture Capital Fund/Multilateral and Bilateral Development Financial Institutions applying on repatriation basis and pink for eligible employees.)
- (b) Completed in full, in BLOCK LETTERS in ENGLISH and in accordance with the instructions contained herein, in the Bid-cum-Application Form or in the Revision Form. Incomplete Bid-cum-Application Forms or Revision Forms are liable to be rejected.
- (c) The Bids from the Retail Individual Bidders must be for a minimum of 45 Equity Shares and in multiples of 45 thereafter subject to a maximum Bid amount of Rs. 100,000.
- (d) For Non-institutional and QIB Bidders, Bids must be for a minimum of such number of equity shares such that the Bid Amount exceeds Rs. 1,00,000 and in multiples of 45 Equity Shares thereafter. Bids cannot be made for more than the Issue size. Bidders are advised to ensure that a single Bid from them should not exceed the investment limits or maximum number of Equity Shares that can be held by them under the applicable laws or regulations.
- (e) In single name or in joint names (not more than three) and in the same order as their depository participant details.
- (f) Thumb impressions and signatures other than in the languages specified in the eighth schedule in the Constitution of India must be attested by a Magistrate or a Notary Public or a Special Executive Magistrate under official seal.

Bids by Employees of the Company

- 1. Bids by the Eligible Employees of the company shall be made only in the prescribed Bid-cum-Application Form or Revision Form, (i.e. Pink colour Bid-cum-Application Form marked "Employees"). Eligible Employees should mention their Employee ID at the relevant place in the Bid-cum-Application Form.
- 2. The sole/first bidder should be Employee of the Company.
- 3. Only Eligible Employees, who are Indian Nationals based in India and are physically present in India on the date of submission of the Bid-cum-Application Form and such person is an employee or Director during the period commencing from the date of filing of the Red Herring Prospectus with the RoC upto the Bid/Issue Closing Date would be eligible to apply in this Issue under the Employee Reservation portion on a competitive basis.
- 4. Employees of the Company will have to Bid like any other Bidder. Only those Bids, which are received at or above the Issue Price, would be considered for allocation under this category.
- 5. Eligible Employees who apply or bid for securities of or for a value of not more than Rs. 1,00,000 in any of the bidding options can apply at Cut-Off. This facility is not available to other eligible employees whose minimum bid amount exceeds Rs. 1,00,000.
- 6. The maximum bid in this category can be 1,76,808 Equity Shares.
- 7. If the aggregate demand in this category is less than or equal to 1,76,808 Equity Shares at or above the Issue Price, full allocation shall be made to the Employees of the Company to the extent of their demand. Under-subscription in this category would be added to any other category.
- 8. If the aggregate demand in this category is greater than 1,76,808 Equity Shares at or above the Issue Price, the allocation shall be made on a proportionate basis subject to a minimum of 45 Equity Shares. For details on the method of proportionate basis of allotment, please refer to sub-section titled "Basis of Allotment or Allocation" in section titled "Issue Procedure" beginning on page 147 of this Red Herring Prospectus.
- 9. Bid/ Application by Eligible Employees can be made also in the Net Issue to Public and such bids shall not be treated as multiple bids.

Vide an undertaking dated 5th April, 2006 the Promoters have confirmed that the Promoter Directors and relatives of the Promoters shall not participate in the Issue.

Bidder's Bank Details

Bidders should note that on the basis of name of the Bidders, Depository Participant's name, Depository Participant-Identification number and beneficiary account number provided by them in the Bid-cum-Application Form, the Registrar to the Issue will obtain from the Depository the Bidders bank account details. These bank account details would be printed on the refund order, if any, to be sent to Bidders or used for sending the refund through direct credit or ECS. Hence, Bidders are advised to immediately update their bank account details as appearing on the records of the depository participant. Please note that failure to do so could result in delays in credit of refunds to Bidders at the Bidders sole risk and neither the BRLMs nor the Bank shall have any responsibility and undertake any liability for the same.



Bidder's Depository Account Details

IT IS MANDATORY FOR ALL THE BIDDERS TO GET THEIR EQUITY SHARES IN DEMATERIALIZED FORM. ALL BIDDERS SHOULD MENTION THEIR DEPOSITORY PARTICIPANT'S NAME, DEPOSITORY PARTICIPANT IDENTIFICATION NUMBER AND BENEFICIARY ACCOUNT NUMBER IN THE BID-CUM-APPLICATION FORM. INVESTORS MUST ENSURE THAT THE NAME GIVEN IN THE BID-CUM-APPLICATION FORM IS EXACTLY THE SAME AS THE NAME IN, WHICH THE DEPOSITORY ACCOUNT IS HELD. IN CASE THE BID-CUM-APPLICATION FORM IS SUBMITTED IN JOINT NAMES, IT SHOULD BE ENSURED THAT THE DEPOSITORY ACCOUNT IS ALSO HELD IN THE SAME JOINT NAMES AND ARE IN THE SAME SEQUENCE IN WHICH THEY APPEAR IN THE BID-CUM-APPLICATION FORM.

Bidders should note that on the basis of name of the Bidders, Depository Participant's name, Depository Participant-Identification number and beneficiary account number provided by them in the Bid-cum-Application Form, the Registrar to the Issue will obtain from the Depository demographic details of the Bidders such as address, bank account details for printing on refund orders or giving credit through ECS or direct credit and occupation ("Demographic Details"). Hence, Bidders should carefully fill in their Depository Account details in the Bid-cum-Application Form.

These demographic details would be used for all correspondence with the Bidders including mailing of the refund orders/ CANs/ allocation advice and printing of bank particulars on the refund order and the demographic details given by Bidders in the Bid-cum-Application Form would not be used for these purposes by the Registrar.

Hence, Bidders are advised to update their demographic details as provided to their Depository Participants and ensure that they are true and correct.

By signing the Bid-cum-Application Form, Bidder would have deemed to authorize the depositories to provide, upon request, to the Registrar to the Issue, the required demographic details as available on its records.

Refund orders/allocation advice/CANs would be mailed at the address of the Bidder as per the demographic details received from the Depositories. Bidders may note that delivery of refund orders/allocation advice/CANs may get delayed if the same once sent to the address obtained from the Depositories are returned undelivered. In such an event, the address and other details given by the Bidder in the Bid-cum-Application Form would be used only to ensure dispatch of refund orders. Please note that any such delay shall be at the Bidders sole risk and neither the Escrow Collection Bank nor the BRLMs shall be liable to compensate the Bidder for any losses caused to the Bidder due to any such delay or liable to pay any interest for such delay.

In case no corresponding record is available with the Depositories that matches three parameters, namely, names of the Bidders (including the order of names of joint holders), the Depository Participant's identity (DP ID) and the beneficiary's identity, then such Bids are liable to be rejected.

Investors should note that the refund cheques would be overprinted with details of bank account as per the details received from the depository.

Bids under Power of Attorney

In case of Bids made pursuant to a power of attorney or by limited companies, corporate bodies, registered societies, a certified copy of the power of attorney or the relevant resolution or authority, as the case may be, along with a certified copy of the Memorandum and Articles of Association and/or Bye Laws must be lodged along with the Bid-cum-Application Form. Failing this, the Company reserves the right to accept or reject any Bid in whole or in part, in either case, without assigning any reason therefore.

In case of the Bids made pursuant to a power of attorney by FIs, a certified copy of the power of attorney or the relevant resolution or authority, as the case may be, along with a certified copy of their SEBI registration certificate must be lodged along with the Bid cum Application Form. Failing this, our Company reserves the right to accept or reject any Bid in whole or in part, in either case, without assigning any reason thereof.

In case of Bids made by insurance companies registered with the Insurance Regulatory and Development Authority, a certified copy of certificate of registration issued by Insurance Regulatory and Development Authority must be lodged along with the Bid-cum-Application Form. Failing this, our Company reserves the right to accept or reject any Bid in whole or in part, in either case, without assigning any reason thereof.

In case of Bids made by provident funds with minimum corpus of Rs. 2500 Lakh and pension funds with minimum corpus of Rs. 2500 Lakh, a certified copy of certificate from a chartered accountant certifying the corpus of the provident fund/ pension fund must be lodged along with the Bid-cum-Application Form. Failing this, our Company reserves the right to accept or reject any Bid in whole or in part, in either case, without assigning any reason thereof.



In case of Bids made by Mutual Funds registered with SEBI, Venture Capital fund registered with SEBI and Foreign Venture Capital Fund registered with SEBI, a certified copy of the SEBI registration certificate must be submitted with the Bid-cum-Application Form. Failing this, our Company reserves the right to accept or reject any Bid in whole or in part, in either case, without assigning any reason thereof.

We, in our absolute discretion, reserve the right to relax the above condition of simultaneous lodging of the power of attorney along with the Bid-cum-Application form, subject to such terms that we may deem fit.

The Company in its absolute discretion, reserve the right to permit the holder of the power of attorney to request the registrar that for the purpose of printing particulars on the refund order and mailing of the refund order / CANs/ Allocation Advice, the demographically details given on the Bid-cum-Application Form should be used (and not those obtained from the depository of the Bidder). In such cases, the registrar shall use demographically details as given in the Bid-cum-Application Form instead of those obtained from depositories.

Bids by Non-Residents, including Eligible NRIs and FIIs, on a repatriation basis

NRI, FIIs and Foreign Venture Capital funds Bidders to comply with the following:

- a) Individual NRI Bidders can obtain the Bid cum Application Forms from our Corporate Office or from members of the Syndicate or the Registrar to the Issue.
- b) NRI Bidders may please note that only such Bids as are accompanied by payment in free foreign exchange through approved banking channels shall be considered for allotment.
- c) NRIs who intend to make payment through Non-Resident Ordinary (NRO) accounts shall use the Bid Cum Application form meant for Resident Indians (white in colour).

Bids and revision to Bids must be made:

1. On the Bid-cum-Application Form or the Revision Form, as applicable (blue in color), and completed in full in **BLOCK LETTERS in ENGLISH** in accordance with the instructions contained therein.
2. In a single name or joint names (not more than three) and in the same order as the depository participant details.
3. Eligible NRIs for a Bid Amount of up to Rs. 100,000 would be considered under the Retail Portion for the purposes of allocation and for a Bid Amount of more than Rs. 100,000 would be considered under Non-Institutional Portion for the purposes of allocation. Other Non-Resident Bidders should bid for a minimum of such number of Equity Shares and in multiples of 45 thereafter that the Bid Amount exceeds Rs. 100,000. For details, please refer to sub-section "Maximum and Minimum Bid Size" beginning on page 132 of this Red Herring Prospectus.
4. In the names of individuals, or in the names of FIIs but not in the names of minors, OCBs, firms or partnerships, foreign nationals (excluding Eligible NRIs) or their nominees.
5. Refunds, dividends and other distributions, if any, will be payable in Indian Rupees only and net of bank charges and/or commission. In case of Bidders who remit money through Indian Rupee drafts purchased abroad, such payments in Indian Rupees will be converted into U.S. Dollars or any other freely convertible currency as may be permitted by the RBI at the rate of exchange prevailing at the time of remittance and will be dispatched by registered post or if the Bidders so desire, will be credited to their NRE accounts, details of which should be furnished in the space provided for this purpose in the Bid cum Application Form. We will not be responsible for loss, if any, incurred by the Bidder on account of conversion of foreign currency.

It is to be distinctly understood that there is no reservation for Non-Residents, including Eligible NRIs and FIIs, and all Non-Resident Bidders will be treated on the same basis with other categories for the purpose of allocation.

The Company does not require approvals from FIPB or RBI for the transfer of Equity Shares in this issue to eligible NRIs, FIIs, Foreign Venture Capital Investors registered with SEBI and multilateral and bilateral institutions. As per the RBIs regulations, OCBs are not permitted to participate in the Issue.

For further details see section titled "Issue Procedure - Maximum and Minimum Bid Size" on page 132 of this Red Herring Prospectus.

Payment Instructions

We shall open an Escrow Account with the Escrow Collection Bank(s) for the collection of the Bid Amounts payable upon submission of the Bid-cum-Application Form and for amounts payable pursuant to allocation in the Issue.

Each Bidder shall draw a cheque or demand draft for the amount payable on the Bid and/or on allocation as per the following terms:



Payment into Escrow Account:

- (a) The Bidders shall along with the submission of the Bid-cum-Application Form draw a payment instrument for the Bid Amount in favour of the Escrow Account and submit the same to the members of the Syndicate.
- (b) In case the above Margin Amount paid by the Bidders during the Bidding Period is less than the Issue Price multiplied by the Equity Shares allocated to the Bidder, the balance amount shall be paid by the Bidders into the Escrow Account within the period specified in the CAN which shall be subject to a minimum period of two days from the date of communication of the allocation list to the Syndicate Member by the BRLMs.
- (c) The payment instruments for payment into the Escrow Account should be drawn in favour of:
 - (i) In case of QIB Bidders: **"Escrow Account –XLTL- Public Issue-QIB"**
 - (ii) In case of Resident Bidders: **"Escrow Account- XLTL-Public Issue"**
 - (iii) In case of Non Resident Bidders: **"Escrow Account- XLTL – Public Issue-NR"**
 - (iv) In case of Eligible Employees: **"Escrow Account-XLTL-Public Issue-Eligible Employees"**
- (d) In case of Bids by NRIs applying on repatriation basis, the payments must be made through Indian Rupee Drafts purchased abroad or cheques or bank drafts, for the amount payable on application remitted through normal banking channels or out of funds held in Non-Resident External (NRE) Accounts or Foreign Currency Non-Resident (FCNR) Accounts, maintained with banks authorized to deal in foreign exchange in India, along with documentary evidence in support of the remittance. Payment will not be accepted out of a Non-Resident Ordinary (NRO) Account of a Non-Resident bidder bidding on a repatriation basis. Payment by drafts should be accompanied by a bank certificate confirming that the draft has been issued by debiting an NRE or FCNR Account.
- (e) In case of Bids by FIIs, the payment should be made out of funds held in a Special Rupee Account along with documentary evidence in support of the remittance. Payment by drafts should be accompanied by a bank certificate confirming that the draft has been issued by debiting the Special Rupee Account.
- (f) Where a Bidder has been allocated a lesser number of Equity Shares than the Bidder has Bid for, the excess amount, if any, paid on Bidding, after adjustment towards the balance amount payable on the Equity Shares allocated, will be refunded to the Bidder from the Escrow Account.
- (g) The monies deposited in the Escrow Account will be held for the benefit of the Bidders until Designated Date.
- (h) On the Designated Date, the Escrow Collection Banks shall transfer the funds from the Escrow Account as per the terms of the Escrow Agreement into the Public Issue Account with the Bankers to the Issue.
- (i) On the Designated Date and no later than 15 days from the Bid/Issue Closing Date, the Escrow Collection Bank shall also refund all amounts payable to unsuccessful bidders and also the excess amount paid on Bidding, if any, after adjusting for allocation to the Bidders.

Payments should be made by cheque, or demand draft drawn on any bank (including a Co-operative bank), which is situated at, and is a member of or sub-member of the bankers' clearing house located at the centre where the Bid-cum-Application Form is submitted. Outstation cheques/bank drafts drawn on banks not participating in the clearing process will not be accepted and applications accompanied by such cheques or bank drafts are liable to be rejected. Cash/ stock invest/money orders/ postal orders will not be accepted. Investors in the QIB Category may also make payment by RTGS.

Payment by Stock invest

In terms of Reserve Bank of India Circular No. DBOD No. FSC BC 42/24.47.00/2003-04 dated November 5, 2003, the option to use the stock invest instrument in lieu of cheques or bank drafts for payment of bid money has been withdrawn. Hence, payment through stockinvest would not be accepted in this Issue.

Submission of Bid-cum-Application Form

All Bid-cum-Application Forms or Revision Forms duly completed and accompanied by account payee cheques or drafts shall be submitted to the Syndicate Member at the time of submission of the Bid. At the time of submission of Bid-cum-Application Form and Revision Form, each member of the Syndicate shall collect the 10% or 100% Margin Amount as may be applicable.

No separate receipts shall be issued for the money payable on the submission of Bid-cum-Application Form or Revision Form. However, the collection center of the Syndicate Member will acknowledge the receipt of the Bid-cum-Application Forms or Revision Forms by stamping and returning to the Bidder the acknowledgement slip. This acknowledgement slip will serve as the duplicate of the Bid-cum-Application Form for the records of the Bidder.



OTHER INSTRUCTIONS

Joint Bids in the case of Individuals

Bids may be made in single or joint names (not more than three). In the case of joint Bids, all payments will be made out in favour of the Bidder whose name appears first in the Bid-cum-Application Form or Revision Form ("First Bidder"). All communications will be addressed to the first Bidder and will be dispatched to his or her address.

Multiple Bids

A Bidder should submit only one Bid-cum-Application Form for bidding in this Issue. Two or more Bids will be deemed to be multiple Bids if the sole or first Bidder is one and the same.

Procedure for Application by Mutual Funds

In case of a Mutual Fund, a separate Bid can be made in respect of each scheme of the Mutual Fund registered with SEBI and such Bids in respect of more than one scheme of the Mutual Fund will not be treated as multiple bids provided that the Bids clearly indicate the scheme concerned for which the Bid has been made.

We reserve the right to reject, in our absolute discretion to accept or reject, all or any multiple Bids in any or all categories.

Permanent Account Number (PAN)

Where Bid(s) is/are for Rs. 50,000 or more, the Bidder or in the case of an Bid in joint names, each of the Bidders, should mention his/her Permanent Account Number (PAN) allotted under the I.T. Act. The copy of the PAN card or PAN allotment letter is required to be submitted with the Bid-cum-Application form. Applications without this information and documents will be considered incomplete and are liable to be rejected. **It is to be specifically noted that Bidders should not submit the GIR number instead of the PAN as the Bid is liable to be rejected on this ground.** In case the sole/first Bidder and joint Bidder(s) is/are not required to obtain PAN, each of the Bidder(s) shall mention "Not Applicable" and in the event that the sole Bidder and/or the joint Bidder(s) have applied for PAN which has not yet been allotted each of the Bidder(s) should mention "Applied for" in the Bid-cum-Application Form. Further, where the Bidder(s) has mentioned "Applied for" or "Not Applicable", the sole/first Bidder and each of the joint Bidder(s), as the case may be, would be required to submit Form 60 (Form of declaration to be filed by a person who does not have a permanent account number and who enters into any transaction specified in rule 114B), or, Form 61 (form of declaration to be filed by a person who has agricultural income and is not in receipt of any other income chargeable to income-tax in respect of transactions specified in rule 114B), as may be applicable, duly filled along with a copy of any one of the following documents in support of the address: (a) Ration Card (b) Passport (c) Driving license (d) Identity card issued by any institution (e) Copy of the electricity bill or telephone bill showing residential address (f) Any document or communication issued by any authority of the Central Government, State Government or local bodies showing residential address (g) Any other documentary evidence in support of address given in the declaration. **It may be noted that Form 60 and Form 61 have been amended vide a notification issued on December 1, 2004 by the Ministry of Finance, Department of Revenue, Central Board of Direct Taxes. All Bidders are requested to furnish, where applicable, the revised Form 60 or 61 as the case may be.**

Unique Identification Number ("UIN")

With effect from July 1, 2005, SEBI had decided to suspend all fresh registrations for obtaining UIN and the requirement to contain/quote UIN under the SEBI MAPIN Regulations/Circulars vide its circular MAPIN/Cir- 13/2005. However, in a recent press release dated December 30, 2005, SEBI has approved certain policy decisions and has now decided to resume registrations for obtaining UINs in a phased manner. The press release states that the cut off limit for obtaining UIN has been raised from the existing limit of trade order value of Rs. 100,000 to Rs. 500,000 or more. The limit will be reduced progressively. For trade order value of less than Rs. 500,000, an option will be available to investors to obtain either the PAN or UIN. These changes are, however, not effective as of the date of the Red Herring Prospectus and SEBI has stated in the press release that the changes will be implemented only after necessary amendments are made to the SEBI MAPIN Regulations.

Therefore, MAPIN is not required to be quoted with the Bids.

Our Right to Reject Bids

The Syndicate Members have right to reject a Bid received from QIB at the receipt of the Bids. However, the Syndicate Members shall disclose the reasons for not accepting the Bid to the Bidder. In case of Non-Institutional Bidders and Retail Individual Bidders and Eligible Employees, The Company & BRLMs have a right to reject bids based on technical grounds. Consequent refunds shall be made by cheque or pay order or draft and will be sent to the bidder's address at the Bidder's risk.



Grounds for Technical Rejections

Bidders are advised to note that Bids are liable to be rejected among others on the following technical grounds:

- 1) Amount paid doesn't tally with the amount payable for the highest value of Equity Shares bid for;
- 2) Age of first Bidder not given;
- 3) In case of Partnership firms, Equity shares may be registered in the names of the individual partners and no firm as such, shall be entitled to apply.
- 4) NRIs, except Eligible NRIs.
- 5) Bids by persons not competent to contract under the Indian Contract Act, 1872, including minors, insane persons;
- 6) PAN not given if Bid is for Rs. 50,000 or more and GIR number given instead of PAN number;
- 7) Bids for lower number of Equity Shares than specified for that category of investors;
- 8) Bids at a price less than lower end of the Price Band;
- 9) Bids at a price more than the higher end of the Price Band;
- 10) Bids at cut-off price by Non-Institutional Bidders and QIB Bidders;
- 11) Bids for number of Equity Shares which are not in multiples of 45;
- 12) Category not ticked;
- 13) Multiple bids as defined in this Red Herring Prospectus;
- 14) In case of Bid under power of attorney or by limited companies, corporate, trust etc., relevant documents are not submitted;
- 15) Bids accompanied by Stock Invest/ money order/postal order/cash;
- 16) Signature of sole and / or joint Bidders missing;
- 17) Bid-cum-Application Form does not have the stamp of the BRLMs or Syndicate Member;
- 18) Bid-cum-Application Form does not have Bidder's depository account details;
- 19) In case no corresponding record is available with the Depository that matches three parameters: name of Bidder (including sequence of names of joint holders), Depository Participant identification number and beneficiary account number;
- 20) Bid-cum-Application Forms are not delivered by the Bidders within the time prescribed as per the Bid-cum-Application Form, Bid/Issue Opening Date advertisement and this Red Herring Prospectus and as per the instructions in this Red Herring Prospectus and the Bid-cum-Application Form;
- 21) Bids for amounts greater than the maximum permissible amounts prescribed by the regulations;
- 22) Bids by OCBs
- 23) Bank account details (for refund) are not given;

Equity Shares in Dematerialized Form with NSDL or CDSL

As per the provisions of Section 68B of the Companies Act, the Equity Shares in this Issue shall be allotted only in a dematerialized form, (i.e. not in the form of physical certificates but be fungible and be represented by the statement issued through the electronic mode).

In this context, two agreements have been signed among us, the respective Depositories and the Registrar to the Issue:

- a) A tripartite agreement dated 06th October 2005 with NSDL, us and BigShare Services Private Limited, Registrar to the Issue;
- b) A tripartite agreement dated 19th September 2005 with CDSL, us and BigShare Services Private Limited, Registrar to the Issue.



All Bidders can seek allotment only in dematerialized mode. Bids from any Bidder without relevant details of his or her Depository Account are liable to be rejected.

- a) A Bidder applying for Equity Shares must have at least one beneficiary account with either of the Depository Participants of either NSDL or CDSL prior to making the Bid.
- b) The Bidder must necessarily fill in the details (including the beneficiary account number and Depository Participant's identification number) appearing in the Bid-cum-Application Form or Revision Form.
- c) Equity Shares allotted to a successful Bidder will be credited in electronic form directly to the beneficiary account (with the Depository Participant) of the Bidder
- d) Names in the Bid-cum-Application Form or Revision Form should be identical to those appearing in the account details in the Depository. In case of joint holders, the names should necessarily be in the same sequence as they appear in the account details in the Depository.
- e) Non-transferable allotment advice or refund orders will be directly sent to the Bidder by the Registrar to this Issue.
- f) If incomplete or incorrect details are given under the heading 'Request for Equity Shares in electronic form' in the Bid-cum-Application Form or Revision Form, it is liable to be rejected.
- g) The Bidder is responsible for the correctness of his or her demographic details given in the Bid-cum-Application Form vis-à-vis those with his or her Depository Participant.
- h) It may be noted that Equity Shares in electronic form can be traded only on the stock exchanges having electronic connectivity with NSDL and CDSL. All the Stock Exchanges where our Equity Shares are proposed to be listed have electronic connectivity with CDSL and NSDL.
- i) The trading of the Equity Shares of the Company would be in dematerialized form only for all investors in the demat segment of the respective Stock Exchanges.

As this Issue comprises of Fresh Issue, investors are advised to instruct their Depository Participants to accept the Equity Shares that may be allocated to them pursuant to this Issue.

In case of pre issue or post issue related problems such as non-receipt of letters of allotment/ refund orders etc., the investors can contact the Compliance Officer.

Communications

All future communications in connection with Bids made in this Issue should be addressed to the Registrar to the Issue quoting the full name of the sole or first Bidder, Bid-cum-Application Form number, details of depository participant, number of Equity Shares applied for, date of bid cum application Form, name and address of the member of the syndicate where the bid was submitted and cheque or draft number and issuing bank thereof.

PRE-ISSUE AND POST ISSUE RELATED PROBLEMS

We have appointed Ch. Bhavani, Company Secretary, as the Compliance Officer and he may be contacted in case of any pre-Issue or post-Issue-related problems. He can be contacted at the following address:

Ch. Bhavani

335, Chandralok Complex,
111 Sarojini Devi Road,
Secunderabad – 500 003
Tel: +91-40-2772 0002
Fax: +91-40-2784 0081
Email: chbhavani@xltelecom.net

Disposal of Applications and Applications Money

We shall ensure dispatch of allotment advice, transfer advice or refund orders and give benefit to the beneficiary account with Depository Participants and submit the documents pertaining to the allotment to the Stock Exchanges within two working days of date of finalisation of allotment of Equity Shares. We shall dispatch refund above Rs. 1,500, if any, by registered post or speed post at the sole or first Bidder's sole risk, except for Bidders who have opted to receive refunds through the ECS facility or RTGS or Direct Credit.

We shall use best efforts to ensure that all steps for completion of the necessary formalities for allotment and trading at all the Stock Exchanges where the Equity Shares are proposed to be listed, are taken within seven working days of finalisation of the basis of allotment.



In accordance with the Companies Act, the requirements of the Stock Exchanges and SEBI Guidelines, we further undertake that:

- allot Equity Shares only in dematerialised form within 15 working days of the Bid/Issue Closing Date;
- dispatch refund orders, except for Bidders who have opted to receive refunds through the ECS facility, within 15 working days of the Bid/Issue Closing Date would be ensured; and
- **Interest in case of delay in dispatch of Allotment Letters/ Refund Orders in case of public issues** – we shall pay interest at 15% per annum (for any delay beyond the 15 day time period as mentioned above), if allotment is not made and refund orders are not dispatched and/or demat credits are not made to investors within the 15 working day time prescribed above.

We will provide adequate funds required for dispatch of refund orders or allotment advice to the Registrar to the Issue.

No separate receipts shall be issued for the money payable on the submission of Bid cum Application Form or Revision Form. However, the collection centre of the Syndicate Member will acknowledge the receipt of the Bid-cum-Application Forms or Revision Forms by stamping and returning to the Bidder the acknowledgement slip. This acknowledgement slip will serve as the duplicate of the Bid cum Application Form for the records of the Bidder.

Mode of making refunds

Bidders should note that on the basis of name of the Bidders, Depository Participant's name, Depository Participant-Identification number and Beneficiary Account Number provided by them in the Bid cum Application Form, the Registrar to the Issue will obtain from the Depository the Bidders bank account details including nine digit MICR code. Hence, Bidders are advised to immediately update their bank account details as appearing on the records of the depository participant. Please note that failure to do so could result in delays in credit of refunds to Bidders at the Bidders sole risk and neither the BRLMs nor the Bank shall have any responsibility and undertake any liability for the same.

The payment of refund, if any, would be done through various modes in the following order of preference

- I. Direct Credit – For investors having their Bank Account with the Escrow Bankers, i.e. HSBC Bank, the refund amount would be credited directly to their Bank Account with the Escrow Banker.
- II. RTGS – Investors desirous of taking direct credit of refund through RTGS, will have to provide the IFSC code in the Bid cum Application form.
- III. ECS - Payment of refund would be done through ECS for applicants residing at one of the 15 centres, namely Ahmedabad, Bangalore, Bhubaneshwar, Kolkata, Chandigarh, Chennai, Guwahati, Hyderabad, Jaipur, Kanpur, Mumbai, Nagpur, New Delhi, Patna and Thiruvananthapuram, where clearing houses for ECS are managed by Reserve Bank of India. This would be subject to availability of complete Bank Account Details including MICR code from the depository.

For all the other applicants excepts for whom payment of refund is possible through I, II and III, the refund orders would be dispatched “Under Certificate of Posting” for refund orders less than Rs. 1500 and through Speed Post/Registered Post for refund orders exceeding Rs. 1500.

Impersonation

Attention of the applicants is specifically drawn to the provisions of sub-section (1) of Section 68 A of the Companies Act, which is reproduced below:

“Any person who:

- (a) makes in a fictitious name, an application to a company for acquiring or subscribing for, any shares therein, or**
- (b) otherwise induces a company to allot, or register any transfer of shares therein to him, or any other person in a fictitious name,**

shall be punishable with imprisonment for a term which may extend to five years.”

Interest on Refund of excess Bid Amount

The Company shall pay interest at the rate of 15% per annum on the excess Bid Amount received if refund orders are not dispatched within 15 days from the Bid/Issue Closing Date as per the Guidelines issued by the GoI, Ministry of Finance pursuant to their letter No.F/8/S/79 dated July 31, 1983, as amended by their letter No. F/14/SE/85 dated September 27, 1985, addressed to the stock exchanges, and as further modified by SEBI's Clarification XXI dated October 27, 1997, with respect to the SEBI Guidelines.



Basis of Allotment or Allocation

A. For Retail Individual Bidders

- Bids received from the Retail Individual Bidders at or above the Issue Price shall be grouped together to determine the total demand under this category. The allocation to all the successful Retail Individual Bidders will be made at the Issue Price.
- The Net Issue to Public less allocation to Non-Institutional and QIB Bidders shall be available for allocation to Retail Individual Bidders who have bid in the Issue at a price, which is equal to or greater than the Issue Price.
- If the aggregate demand in this category is less than or equal to 13,23,000 Equity Shares at or above the Issue Price, full allocation shall be made to the Retail Individual Bidders to the extent of their demand.
- If the aggregate demand in this category is greater than 13,23,000 Equity Shares at or above the Issue Price, the allocation shall be made on a proportionate basis up to a minimum of 45 Equity Shares and multiples of 1 Equity Shares thereafter. For the method of proportionate basis of allotment, refer below.

B. For Non-Institutional Bidders

- Bids received from Non Institutional Bidders at or above the Issue Price shall be grouped together to determine the total demand under this category. The allocation to all successful Non-Institutional Bidders will be made at the Issue Price.
- The Net Issue to Public less allocation to QIBs and Retail Portion shall be available for allocation to Non-Institutional Bidders who have bid in the Issue at a price, which is equal to or greater than the Issue Price.
- If the aggregate demand in this category is less than or equal to 5,67,000 Equity Shares at or above the Issue Price, full allocation shall be made to Non-Institutional Bidders to the extent of their demand.
- In case the aggregate demand in this category is greater than 5,67,000 Equity Shares at or above the Issue Price, allocation shall be made on a proportionate basis up to a minimum of 45 Equity Shares and in multiples of 1 Equity Share thereafter. For the method of proportionate basis of allotment, refer below.

C. For QIB Bidders

- Bids received from the QIB Bidders at or above the Issue Price shall be grouped together to determine the total demand under this portion. The allocation to all the QIB Bidders will be made at the Issue Price.
- The Net Issue to Public less allocation to Non-Institutional Portion and Retail Portion shall be available for allocation to QIB Bidders who have bid in the Issue at a price, which is equal to or greater than the Issue Price.
- Allotment shall be undertaken in the following manner:
 - (a) In the first instance allocation to Mutual Funds for upto 5% of the QIB Portion shall be determined as follows;
 - (i) In the event that Mutual Fund Bids exceeds 5% of the QIB Portion, allocation to Mutual Funds shall be done on a proportionate basis for upto 5% of the QIB Portion.
 - (ii) In the event that the aggregate demand for Mutual Funds is less than 5% of the QIB Portion then all Mutual Funds shall get full allotment to the extent of valid Bids received above the Issue Price.
 - (iii) Equity Shares remaining unsubscribed, if any, not allocated to Mutual Funds shall be available to all QIB Bidders as set out in (b) below;
 - (b) In the second instance allocation to all QIBs shall be determined as follows:
 - (i) In the event of the over-subscription in the QIB Portion, all QIB Bidders who have submitted Bids above the Issue Price shall be allotted Equity Shares on a proportionate basis for up to 95% of the QIB Portion.
 - (ii) Mutual Funds, who have received allocation as per (a) above, for less than the number of Equity Shares Bid for by them, are eligible to receive Equity Shares on a proportionate basis along with other QIB Bidders.
 - (iii) Under-subscription below 5% of the QIB Portion, if any, from Mutual Funds, would be included for allocation to the remaining QIB Bidders on a proportionate basis.
 - (c) The aggregate allocation to QIB Bidders shall not be more than 18,90,000 Equity Shares.

Under-subscription, if any, in the Non-Institutional and Retail Individual categories would be allowed to be met with spill over from any other category at the sole discretion of the Company and the BRLMs.



D. For our Eligible Employees

- In case of under-subscription in the Net Issue, spillover to the extent of under-subscription shall be permitted from the Employee Reservation Portion.
- Bids received from the Employees at or above the Issue Price shall be grouped together to determine the total demand under this category. The allocation to all the successful Employees will be made at the Issue Price.
- If the aggregate demand in this category is less than or equal to 1,56,808 Equity Shares at or above the Issue Price, full allocation shall be made to the Employees to the extent of their demand.
- If the aggregate demand in this category is greater than 1,56,808 Equity Shares at or above the Issue Price, the allocation shall be made on a proportionate basis up to a minimum of 45 Equity Shares. For the method of proportionate basis of allocation, refer below.
- Only Eligible Employees are eligible to apply under the Employee Reservation Portion.

Procedure and Time Schedule for Transfer of Equity Shares

The Company has a right to reject Bids on technical grounds only. In case a Bid is rejected in full, the whole of the Bid Amount will be refunded to the Bidder within 15 days of the Bid/Issue Closing Date. In case a Bid is rejected in part, the excess Bid Amount will be refunded to the Bidder within 15 days of the Bid/Issue Closing Date. The Company will ensure allotment of the Equity Shares within 15 days from the Bid/Issue Closing Date, and the Company shall pay interest at the rate of 15% per annum (for any delay beyond the periods as mentioned above), if Equity Shares are not allotted, refund orders are not dispatched and/or demat credits are not made to investors within two working days from the date of allotment.

Method of Proportionate Basis of Allotment

In the event the Issue is over-subscribed, the basis of allotment shall be finalised by the Company in consultation with the Designated Stock Exchange. The Executive Director or Managing Director (or any other senior official nominated by them) of the Designated Stock Exchange along with the BRLMS and the Registrar to the Issue shall be responsible for ensuring that basis of allotment is finalised in a fair and proper manner. Allotment to Bidders shall be as per the basis of allocation as set out in this Prospectus under "Issue Structure".

- a) Bidders will be categorised according to the number of Equity Shares applied for.
- b) The total number of Equity Shares to be allotted to each category, as a whole shall be arrived at on a proportionate basis, which is the total number of Equity Shares applied for in that category (number of bidders in the category multiplied by number of Equity Shares applied for) multiplied by the inverse of the over-subscription ratio.
- c) Number of Equity Shares to be allotted to the successful Bidders will be arrived at on a proportionate basis which is total number of Equity Shares applied for by each Bidder in that category multiplied by the inverse of the over-subscription ratio in that category subject to minimum allotment of 45 Equity Shares. The minimum allotment lot shall be the same as the minimum application lot irrespective of any revisions to the Price Band.
- d) In case the proportionate allotment to any Bidders is in fractions, then the same would be rounded off to nearest integer.
- e) In all bids where the proportionate allotment is less than 45 per Bidder, the allotment shall be made as follows:
 - Each successful Bidder shall be allotted a minimum of 45 Equity Shares; and
 - The successful Bidders out of the total Bidders for a category shall be determined by draw of lots in a manner such that the total number of Equity Shares allotted in that category is equal to the number of Equity Shares calculated in accordance with (b) above.

If the Equity Shares allocated on a proportionate basis to any category are more than the Equity Shares allotted to the Bidders in that category, the remaining Equity Shares available for allotment shall be first adjusted against any other category, where the allotted Equity Shares are not sufficient for proportionate allotment to the successful bidders in that category. The balance Equity Shares, if any, remaining after such adjustment will be added to the category comprising of bidders applying for minimum number of Equity Shares.

Letters of Allotment or Refund Orders

We shall give credit of Equity Share allotted to the beneficiary account with Depository Participants within 15 working days of the Bid Closing Date / Issue Closing Date. Applicants residing at 15 centres where clearing houses are managed by the Reserve Bank of India (RBI) will get refunds through ECS only (subject to availability of all information for crediting the refund through



ECS) except where applicant is otherwise disclosed as eligible to get refunds through direct credit and RTGS. In case of other applicants, the Bank shall ensure dispatch of refund orders, if any, of value up to Rs. 1,500 by “Under Certificate of Posting”, and shall dispatch refund orders above Rs. 1,500, if any, by registered post or speed post, except for Bidders who have opted to receive refunds through the ECS facility. Applicants to whom refunds are made through Electronic transfer of funds will be send a letter through ordinary post intimating them about the mode of credit of refund within 15 working days of closure of Issue.

We shall ensure dispatch of refund orders, if any, by “Under Certificate of Posting” or registered post or speed post or Electronic Clearing Service or Direct Credit or RTGS, as applicable, only at the sole or First Bidder’s sole risk within 15 days of the Bid Closing Date/Issue Closing Date, and adequate funds for making refunds to unsuccessful applicants as per the mode(s) disclosed shall be made available to the Registrar to the Issue by the issuer.

In accordance with the Companies Act, the requirements of the Stock Exchanges and the SEBI Guidelines, we further undertake that:

- Allotment of Equity Shares will be made only in dematerialised form within 15 working days from the Bid/Issue Closing Date;
- Dispatch of refund orders will be done within 15 working days from the Bid/Issue Closing Date;
- We shall pay interest at 15% per annum (for any delay beyond the 15 day time period as mentioned above), if allotment is not made, refund orders are not dispatched and/or demat credits are not made to investors within the 15 working day time prescribed above as per the guidelines issued by the Government of India, Ministry of Finance pursuant to their letter No.F/8/S/79 dated July 31, 1983, as amended by their letter No.F/14/SE/85 dated September 27, 1985, addressed to the Stock Exchanges and as further modified by SEBI’s clarification XXI dated October 27, 1997, with respect to the SEBI Guidelines.

We will provide adequate funds required for dispatch of refund orders or allotment advice to the Registrar to the Issue. Refunds will be made by cheques, pay-orders or demand drafts drawn on a bank appointed by us, as an Escrow Collection Bank and payable at par at places where Bids are received, except for Bidders who have opted to receive refunds through the ECS facility. Bank charges, if any, for encashing such cheques, pay orders or demand drafts at other centres will be payable by the Bidders.

Undertaking by our Company

We undertake as follows:

- that the complaints received in respect of this Issue shall be attended to by us expeditiously and satisfactorily;
- that all steps will be taken for the completion of the necessary formalities for listing and commencement of trading at all the Stock Exchanges where the Equity Shares are proposed to be listed within seven working days of finalisation of the basis of Allotment;
- that funds required for making refunds to unsuccessful applicants as per the mode(s) disclosed shall be made available to the Registrar to the Issue by us;
- that where refunds are made through electronic transfer of funds, a suitable communication shall be sent to the applicant within 15 working days of closure of the issue, giving details of the bank where refunds shall be credited along with amount and expected date of electronic credit of refund. That the refund orders or allotment advice to the successful bidders shall be dispatched within specified time;
- that the refund orders or allotment advice to the Non Residents shall be dispatched within specified time; and
- that no further issue of Equity Shares shall be made till the Equity Shares offered through this Red Herring Prospectus are listed or until the Bid monies are refunded on account of non-listing, under-subscription etc.

Utilisation of Issue proceeds

Our Board of Directors certify that:

- o All monies received out of the Issue shall be transferred to a separate bank account other than the bank account referred to in sub-section (3) of Section 73 of the Companies Act;
- o Details of all monies utilized out of the Issue referred above shall be disclosed under an appropriate separate head in the balance sheet of the Company indicating the purpose for which such monies have been utilized;
- o Details of all unutilized monies out of the Issue, if any, shall be disclosed under the appropriate separate head in the balance sheet of the Company indicating the form in which such unutilized monies have been invested.



- o The Company shall not have recourse to the Issue proceeds until the approval for trading of the Equity Shares from all the Stock Exchanges where listing is sought has been received.
- o The utilisation of monies received under Promoters' contribution shall be disclosed under an appropriate head in the balance sheet of the Company indicating the purpose for which such monies have been utilized; and
- o The details of all unutilised monies out of the funds received under Promoters' contribution shall be disclosed under a separate head in the balance sheet of the Company indicating the form in which such unutilised monies have been invested..

Restrictions on Foreign Ownership of Indian Securities

Foreign investment in Indian securities is regulated through the industrial policy of Government of India, or the Industrial Policy and FEMA. While the Industrial Policy prescribes the limits and the conditions subject to which foreign investment can be made in different sectors of the Indian economy, FEMA regulates the precise manner in which such investment may be made. Under the Industrial Policy, unless specifically restricted, foreign investment is freely permitted in all sectors of Indian economy to any extent and without any prior approvals, but the foreign investor is required to follow certain prescribed procedures for making such investment. The government bodies responsible for granting foreign investment approvals are the Foreign Investment Promotion Board of the Government of India ("FIPB") and the RBI. Under present regulations, the maximum permissible FII investment in our Company is restricted to 24% of our total issued capital. This can be raised to 100% by adoption of a Board resolution and special resolution by our shareholders; however, as of the date hereof, no such resolution has been recommended to Board or our shareholders for adoption.

By way of Circular No. 53 dated December 17, 2003, the RBI has permitted FIIs to subscribe to shares of an Indian company in a public Issue without prior RBI approval, so long as the price of Equity Shares to be issued is not less than the price at which Equity Shares are issued to residents.

The transfer of Equity Shares of NRIs, FIIs, and Foreign Venture Capital Investors registered with SEBI and Multilateral and Bilateral Development Financial institutions shall be subject to the conditions as may be prescribed by the government of India or RBI while granting such approvals.

RIGHTS OF MEMBERS

The Equity Shareholders shall have the following rights:

- Right to receive dividend, if declared;
- Right to attend general meetings and exercise voting powers, unless prohibited by law;
- Right to vote on a poll either in person or by proxy;
- Right to receive offers for rights shares and be allotted bonus shares, if announced;
- Right to receive surplus on liquidation;
- Right of free transferability; and
- Such other rights, as may be available to a shareholder of a listed public company under the Companies Act and our Memorandum and Articles.

For a detailed description of the main provisions of the Articles relating to, among other things, voting rights, dividend, forfeiture and lien, transfer and transmission see the section titled "Main Provisions of the Articles of Association" on page 151 of this Red Herring Prospectus.



SECTION XI - MAIN PROVISIONS OF ARTICLES OF ASSOCIATION

MAIN PROVISIONS OF ARTICLES OF ASSOCIATION OF XL TELECOM LIMITED Pursuant to Schedule II of the Companies Act, 1956 and the SEBI guidelines, the important provisions of the Articles of Association of our Company relating to members voting rights, lien on Equity Shares and process for modification of such rights, forfeiture of Equity Shares, restrictions on transfer and transmission of Equity Shares and debentures and on their consolidation and splitting are detailed below.

3. Amount of Capital.	The Authorised Share Capital of the Company is Rs. 20,00,00,000/- (Rupees Twenty Crores only) divided into 2,00,00,000 (Two Crores only) Equity shares of Rs. 10/- (Rupees Ten) each.
4. Increase of capital by the Company and how carried into effect.	The Company in General Meeting may, from time to time, increase the capital by the creation of new shares. Subject to the provisions of the Act, any shares of the original or increased capital shall be issued upon such terms and conditions as the General Meeting resolving upon creation thereof shall direct, and if no direction be given, as the Directors shall determine and, in particular, such shares may be issued with a preferential or qualified right to dividend and the distribution of assets of the Company, and with a right of voting at General Meetings of the Company in conformity with Sections 87 and 88 of the Act. Whenever the Capital of the Company has been increased under the provisions of this Article, the Directors shall comply with the provisions of Section 97 of act.
5. New capital same as existing capital.	Except so far as otherwise provided by the conditions of issue or by those presents any capital raised by the creation of new shares shall be considered as part of the existing capital, and shall be subject to the provisions herein contained, with reference to the payment of calls and installments, forfeiture, lien, surrender, transfer and transmission, voting and otherwise.
6. Redeemable Preference Shares.	Subject to the provisions of Sections 80 and 80A of the Act the Company shall have the power to issue preference shares which are, or at the option of the Company are, liable to be redeemed and the resolution authorizing such issue shall prescribe the manner, terms and conditions of redemption.
7. Reduction of capital	The Company may (subject to the provisions of Sections 78, 80, 100 to 105 inclusive of the Act) from time to time by Special Resolution, reduce its capital, any Capital Redemption Reserve Account and Share Premium Account in any manner for the time being authorized by law, and in particular, capital may be paid off on the footing that it may be called up again or otherwise. This article is not to derogate from any power the Company would have if it were omitted.
8. Sub-division, consolidation and cancellation of shares.	Subject to the provisions of Section 94 of the Act, the Company in General Meeting may, from time to time, sub-divide or consolidate its shares, or any of them and the resolution whereby any share is sub-divided, may determine that, as between the holders of the shares resulting from such sub-division one or more of such shares shall have some preference or special advantage as regards dividend, capital or otherwise over or as compared with the others or other. Subject as aforesaid the Company in general meeting may also cancel shares which have not been taken or agreed to be taken by any person and diminish the amount of its share capital by the amount of the shares so cancelled.
9. Modification of rights	Whenever the capital, by reason of the issue of preference shares or otherwise, is divided into different classes shares, all or any of the rights and privileges attached to each class may, subject to the provisions of Sections 106 and 107 of the Act, be modified, commuted, affected or abrogated, or dealt with by Agreement between the Company and any person purporting to contract on behalf of that class, provided such agreement is ratified in writing by holders of at least three-fourths in nominal value of the issued shares of the class or is confirmed by a Special Resolution passed at a separate general meeting of the holders of shares of that class.

SHARES AND CERTIFICATES

10. Register and index of Members	The Company shall cause to be kept a Register of Members, an Index of Members, a register of Debenture holders, Index of Debenture holders in accordance with section 150, 151 and 152 of the Act.
-----------------------------------	--



Provided that nothing contained in this Article shall apply to the securities held with a Depository. In case of securities held by a Depository, the register of beneficial owner maintained by a depository under the Depositories Act, shall be deemed to be a register of shareholders or debenture holders as the case may be.

- 10A Company to recognize interest in securities other than that of registered holder, under the Depositories Act, 1996
- Power to company to dematerialize and rematerialize
- Options for Investors
- Intimation to Depository
- Service of documents on the Company
11. Shares to be numbered progressively and no share to be subdivided.
12. a) Declaration by persons not holding beneficial interest in any shares.
- (a) Either the Company or the investor may exercise an option to issue, deal in, hold the securities (including shares) with a depository in electronic form and the certificates in respect thereof shall be dematerialised, in which event the rights and obligations of the parties concerned and matters connected therewith or incidental thereto, shall be governed by the provisions of the Depositories Act, 1996, as amended from time to time or any statutory modification thereto or re-enactment thereof.
- (b) The Company shall be entitled to dematerialize its existing shares, debentures and other securities, rematerialize its shares, debentures and other securities held in the Depositories and / or offer its fresh shares and debentures and other securities in a dematerialized form pursuant to the Depositories Act, 1996 and the rules framed thereunder, if any.
- (c) Every person subscribing to or holding securities of the Company shall have the option to receive security certificates or to hold the securities with a depository. Such a person who is the beneficial owner of the securities can at any time opt out of a depository, if permitted by the law, in respect of any security in the manner provided by the Depositories Act, 1996, and the Company shall, in the manner and within the time prescribed, issue to the beneficial owner the required Certificates of Securities.
- (d)
- (i) Notwithstanding anything to the contrary contained in the Act or these Articles, a depository shall be deemed to be the registered owner for the purposes of effecting transfer of ownership of security on behalf of the beneficial owner.
- (ii) Save as otherwise provided in (a) above, the depository as the registered owner of the securities shall not have any voting rights or any other rights in respect of the securities held by it.
- (iii) Every person holding securities of the Company and whose name is entered as the beneficial owner in the records of the depository shall be deemed to be a member of the Company. The beneficial owner of the securities shall be entitled to all the rights and benefits and be subject to all the liabilities in respect of his securities which are held by a depository.
- (e) Notwithstanding anything contained in this clause, where securities are dealt with in a depository, the Company shall intimate the details of allotment of securities to depository immediately on allotment of such securities.
- (f) Where securities are held in a depository, the records of the beneficial ownership may be served by such depository on the Company by means of electronic mode or by delivery of floppies or discs.
- The shares in the capital shall be numbered progressively according to their several denominations and, except in the manner hereinbefore mentioned, no share shall be sub-divided. Every forfeited, or surrendered share shall continue to bear the number by which the same was originally distinguished.
- Notwithstanding anything herein contained, a person whose name is at any time entered into the Register of Members of the Company as the holder of a share in the Company, but who does not hold the beneficial interest in such share, shall within such time and in such form as may be prescribed, make a declaration to the Company specifying the name and other particulars of the person or persons who hold the beneficial interest in such share in the manner provided in Section 187-C of the Act.



- b) A person who holds a beneficial interest in a share or a class of shares of the Company shall, within the time prescribed, after his becoming such beneficial owner, make a declaration to the Company specifying the name and other particulars of the person or persons who hold the beneficial interest in such share in the manner provided in Section 187-C of the Act.
 - c) Whenever there is a change in the beneficial interest in a share referred to above, the beneficial owner shall, within the time prescribed from the date of such change make a declaration to the Company in such form and containing such particulars as may be prescribed as provided in Section 187-C of the Act.
 - d) Notwithstanding anything contained in Section 153 of the Act and this Article, where any declaration referred to above is made to the Company, the Company shall make a note of such declaration in the Register of Members and file within the time prescribed from the date of receipt of the declaration a return in the prescribed form with the Register with regard to such declaration.
13. a) Further issue of Capital Where at any time after expiry of two years from the formation of the Company or at any time allotment of shares in the Company made for the first time after its formation, whichever is earlier, it is proposed to increase the subscribed capital of the company by allotment of further shares, whether out of unissued share capital or out of increased share capital, then such further shares shall be offered to the persons who at the date of the offer, are holders of the equity shares of the company, in proportion, as nearly as circumstances admit, to the capital paid up on these shares at that date. Such offer shall be made by a notice specifying the number of shares offered and limiting a time not being less than fifteen days from the date of the offer within which the offer, if not accepted, will be deemed to have been declined. After the expiry of the time specified in the notice aforesaid or on receipt of earlier information from the person to whom such notice is given that he declines to accept the shares offered, the Board may dispose off them in such manner as they think most beneficial to the Company.
- b) Notwithstanding anything contained in the preceding sub-clause, the Company may : i) by a special resolution; or ii) Where no such special resolution is passed, if the votes cast (whether on a show of hands or on a poll, as the case may be) in favour of the proposal contained in the resolution moved in that general meeting (including the casting vote, if any, of the Chairman) by Members who, being entitled so to do, vote in person, or where proxies are allowed, by proxy, exceed the votes, if any, cast against the proposal by Members so entitled and voting and the Central Government is satisfied, on an application made by the Board of Directors in this behalf, that the proposal is most beneficial to the Company. Offer further shares to any person or persons, and such person or persons may or may not include the persons who at the date of the offer, are the holders of the equity shares of the Company.
 - c) Notwithstanding anything contained in sub-clause (a) above, but subject, however, to Section 81 (3) of the Act, the Company may increase its subscribed capital on exercise of an option attached to the debentures or loans into shares, or to subscribe for shares in the company.
14. Shares under control of Directors Subject to the provisions of these Articles and of the Act, the shares (including any shares forming part of any increased capital of the company) shall be under the control of the Directors, who may allot or otherwise dispose off the same to such persons in such proportion on such terms and conditions and at such times as the Directors think fit and, subject to the sanction of the Company in General Meeting, to give any person the option to call for or be allotted shares of any class of the company either (subject to the provision of Sections 78 and 79 of the Act) at a premium or at par or at a discount and such option being exercisable for such time and for such consideration as the Directors think fit. The Board shall cause to be filed the returns as to allotment provided for in Section 75 of the Act.



15. Acceptance of shares. Any application signed by or on behalf of an applicant for shares in the company, followed by an allotment of any shares therein, shall be an acceptance of shares within the meaning of these Articles, and every person who thus or otherwise accepts any shares and whose name is on the Register shall for the purposes of these Articles, be a Member.
16. Deposit and call etc., to be a debt payable immediately. The money (if any) which the Board shall, on the allotment of any shares being made by them, require or direct to be paid by way of deposit, call or otherwise in respect of any shares allotted by them, shall immediately on the insertion of the name of the allottee in the Register of Members as the name of the holder of such shares, become a debt due to and recoverable by the Company from the allotted thereof, and shall be paid by him accordingly.
17. Liability of Members. Every Member, or his heirs, executors or administrators shall pay to the Company the portion of the capital represented by his share or shares which may, for the time being, remain unpaid thereon, in such amounts, at such time or times, and in such manner as the Board shall, in accordance with the Company's regulations, require or fix for the payment thereof.
18. a) Share certificates. Every member or allottee of shares, shall be entitled, without payment, to Certificate specifying the name of the person in whose favour it is issued, the shares to which it relates and the amount paid up thereon. Such certificate shall be issued only in pursuance of a resolution passed by the Board and on surrender to the Company of the Letter of Allotment or the fractional coupons of requisite value, save in cases of issues against letters of acceptance or of renunciation or in cases of issue of bonus shares. Every such certificate shall be issued under the seal of the company, which shall be affixed in the presence of two Directors one of whom shall be a Managing Director, if any, or persons acting on behalf of the Directors under a duly registered power of attorney and the Secretary or other authorized person shall sign the Share Certificate. Particulars of every Share Certificate issued shall be entered in the Register of Members against the name of the person to whom it has been issued, indicating the date of issue. The Company shall comply with the provisions of Section 113 of the Act.
- b) Any two or more joint allottees on a share shall, for the purposes of these Articles, be treated as a single Member, and the Certificate of any share, which may be subject to joint ownership may be delivered to anyone of such joint owners on behalf of all of them.
- c) A director may sign a Share Certificate by affixing his signature thereon by means of any machine, equipment or other mechanical means such as engraving in metal or lithography, but not by means of a rubber stamp, provided that the Director shall be responsible for the safe custody of such machine, equipment or other material used for the purpose.
19. a) Renewal of Share Certificate. No Certificate of any share or shares shall be issued either in exchange for those which are sub-divided or consolidated or in replacement of those which are defaced, torn or old, decrepit, worn out, or where the reverse for recording transfers have been duly utilized, unless the certificate, in lieu of which it is issued, is surrendered to the Company.
- b) When a new Share Certificate has been issued in pursuance of clause (a) of this Article, it shall state on the face of it and against the stub or counterfoil to the effect that it is "issued in lieu of share certificate No. sub-divided / replaced / on consolidation of shares".
- c) If a Share Certificate is lost or destroyed, a new certificate in lieu thereof shall be issued only with the prior consent of the Board and on such terms, if any, as to evidence and indemnify and as to the payment of out-of-pocket expenses incurred by the Company in investigating title as the Board think fit.
- d) When a new Share Certificate has been issued in pursuance of clause (c) of this article, it shall state on the face of it and against the stub or counterfoil to the effect that it is "Duplicate" issued in lieu of Share Certificate No. The Word "Duplicate" shall be stamped or punched in bold letters across the face of the Share Certificate.
- e) Where a new share Certificate has been issued in pursuance of clause (a) or clause (c) of this Article, particulars of every such share Certificate shall be entered in a Register of Renewed and Duplicate Certificates indicating against the names of the persons to whom



the certificates is issued, the number and date of the share Certificate in lieu of which the new Certificate is issued and the necessary changes indicated in the Register of Members by suitable cross reference in the "Remarks" column.

- f) All blank forms to be used for issue of Share Certificates shall be printed and the printing shall be done only on the authority of a resolution of the Board. The blank forms shall be consecutively machine – numbered and the forms and blocks, engravings, facsimiles and hues relating to the printing of such forms shall be kept in the custody of the Secretary or such other person as the Board may appoint for the purpose, and the Secretary or the other person aforesaid shall be responsible for rendering an account of these forms to the board.
20. The first name of joint holder deemed sole holder. If any share stands in the names of two or more persons, the person first named in the register shall, as regards receipt of dividends on bonus or serving of notices and all or any other matter connected with the Company, except voting at meetings and the transfer of the shares, be deemed the sole holder thereof; but the joint – holders of a share shall be severally as well as jointly liable for the payment of all installments thereof according to the Company's regulations.
21. Company not bound to recognize any interest in shares other than that of registered holder. Except as ordered by a Court of competent jurisdiction or as by law required, the company shall not be bound to recognize any equitable, contingent, future, or partial interest in any share, or (except only as is otherwise expressly provided by these Articles) any right in respect of a share other than an absolute right thereto, in accordance with these Articles, in the person from time to time registered as the holder thereof; but the board shall be at liberty at their sole discretion to register any share in the joint names of any two or more persons or the survivor or survivors of them.
22. Funds of Company may not be applied in purchase of shares of the company. None of the funds of the Company shall be applied in the purchase of any shares of the Company, and it shall not give any financial assistance for or in connection with the purchase of subscription of any shares in the company or in its holding company save as provided by Section 77 of the Act.
- 22A
- a) Every holder of Shares in, or holder of Debentures of the Company may, at any time nominate, in the prescribed manner under Section 109A of the Act, a person to whom his Shares in, or Debentures of, the Company shall vest in the event of his death.
 - b) Any person who becomes a nominee by virtue of the provision of the Section 109A of the Act, upon the production of such evidence as may be required by the Board and subject as hereinafter provided, elect, either.
 - (i) To be registered himself as holder of the Share or Debenture, as the case may be; or
 - (ii) To make such transfer of the Share or Debenture, as the case may be, as the deceased Shareholder or Debenture holder, as the case may be, could have made as required under Section 109B of the Companies Act, 1956."

UNDERWRITING AND BROKERAGE

23. Commission may be paid. Subject to the provisions of Section 76 of Act, the Company may at any time pay a commission to any person in consideration of his subscribing or agreeing to subscribe (whether absolutely or conditionally) for any shares in or debentures of the company, or procuring, or agreeing to procure subscriptions (whether absolute or conditional) for any shares in or debentures of the company, but so that the commission shall not exceed in the case of shares, five percent of the price at which the shares are issued and, in the case of debentures are issued. Such commission may be satisfied by payment of cash or by allotment of fully or partly paid shares or partly in one way and partly in the other.
24. Brokerage. The Company may pay a reasonable sum for brokerage.



INTEREST OUT OF CAPITAL

25. Where any shares are issued for the purpose of raising money to defray the expenses of the construction of any work or building, or the provision of any plant which cannot be made profitable for a lengthy period, the company may pay interest on so much of that share capital as is for the time being paid up, for the period, at the rate and subject to the conditions and restrictions provided by section 208 of the Act, and may charge the same capital as part of the cost of construction of the work or building, or the provision of plant.

CALLS

26. The board may, from time to time, subject to the terms on which any shares may have been issued and subject to the conditions of allotment, by a resolution passed at a meeting of the Board (and not by circular resolution) make such call or calls as it thinks fit upon the Members in respect of all monies unpaid on the shares held by them respectively; and each member shall pay the amount of every call so made on him to the person or persons and the times and places appointed by the Board. A call may be made payable by installments.
27. Notice of calls. Fourteen days notice in writing of any call shall be given by the company specifying the time and place of payment, and the person or persons to whom such calls shall be paid.
28. Call to date from resolution. A call shall be deemed to have been made at the time when the resolution authorizing such call was passed at a meeting of the Board.
29. Call may be revoked or postponed. A call may be revoked or postponed at the discretion of the Board.
30. Liability of joint holders. The joint holders of a share shall be jointly and severally liable to pay all calls in respect thereof.
31. Directors may extend time. The board may, from time to time, at its discretion extend the time fixed for the payment of any call.
32. Calls to carry interest. If any member fails to pay any call due from him on the day appointed for payment thereof or any such extension thereof as aforesaid, he shall be liable to pay interest on the same from the day appointed for the payment thereof to the time of actual payment at such rate as shall, from time to time, be fixed by the Board not exceeding 18 percent per annum but nothing in this Article shall render it obligatory for the Board to demand or recover any interest from any such member.
33. Sums deemed to be calls. Any sum, which by the terms of issue of a share becomes payable on allotment or at any fixed rate, whether on account of the nominal value of the share or by way of premium, shall for the purposes of these articles be deemed to be a call duly made and payable on the date on which by the terms of issue the same becomes payable; and in case of non-payment all the relevant provisions of these Articles as to payment of interest and expenses, forfeiture or otherwise shall apply as if such sum had become payable by virtue of a call duly made and notified.
34. Partial payment not to preclude for forfeiture. Neither the receipt by the Company of a portion of any money which shall from time to time be due from any Member to the Company in respect of his shares, either by way of principal or interest, nor any indulgence granted by the company in respect of the payment of any such money, shall preclude the company from thereafter proceeding to enforce a forfeiture of such shares as herein after provided.
35. a) Payment in anticipation of calls may carry interest. The board may, if it thinks fit, agree to and receive from any Member willing to advance the same, all or any part of the amounts of his shares beyond the sums actually upon and upon the monies so paid in advance or upon so much thereof, from time to time and at any time thereafter as exceeds the amount of the calls then made upon and due in respect of the shares on account of which such advances are made, the Board may pay or allow interest at such rate (not exceeding without the sanction of the company in General Meeting 18 percent per annum) as the Member paying the sum in advance and the Board agree upon. The Board may agree to repay at any time any amount so advanced or may at any time repay the same upon giving to the Member three months



notice in writing. Provided that money paid in advance of calls shall not confer a right to dividend or to participate in profit.

- b) No member paying any such sum in advance shall entitled to voting rights in respect of the monies so paid by him until the monies so paid by him would, but for such payment, become presently payable.
36. Company's lien on shares Subject to the provision hereinafter contained, the Company shall have a first and paramount lien upon all the Shares registered in the name of each Member (whether solely or jointly with others) and upon the proceeds of sale thereof, for his debts, liabilities and engagements solely or jointly with any other person to or with the company whether the period for the payment, fulfillment or discharge thereof shall have actually arrived or not and no equitable interest in any share shall be created except upon the footing and condition that Article 37 is to have full effect, provided that fully paid shares shall be free from such lien and in the case of partly paid shares, the Company shall have a lien only for money called or payable at a fixed time in respect of such shares and such lien shall extend to all dividends from time to time declared in respect of such shares. Unless otherwise agreed the registration of a transfer of shares shall operate as a waiver of the company's lien, if any, on such shares.
37. As to enforcing lien by sale. For the purpose of enforcing such lien the board may sell the share subject thereto in such manner as they shall think fit, and for that purpose may cause to be issued a duplicate certificate in respect of such shares and may authorize one of their number to execute a transfer thereof on behalf of and in the name of such Member. No sale shall be made until such period as aforesaid have arrived, and until notice in writing of the intention to sell shall have been served on such Member or his representatives and default shall have been made by him or them in payment, fulfillment, or discharge of such debts, liabilities or engagements for fourteen days after such notice.
38. The net proceeds of any such sale shall be received by the company and applied in or towards payments of such part of the amount in respect of which the lien exists as is presently payable and the residue, if any, shall (subject to a like lien for sums not presently payable as existed upon the shares before the sale) be paid to the persons entitled to the shares at the date of the sale.

FORFEITURE OF SHARES

39. If money payable on share not paid, notice to be given to Member. If any Member fails to pay any call to installment of a call on or before the day appointed for the payment of the same or any such extension thereof as aforesaid, the Board may at any time thereafter, during such time as the call or installment remains unpaid, give notice to him requiring him to pay the same together with any interest that may have accrued and all expenses that may have been incurred by the Company by reason of such non-payment.
40. Terms of notice. The notice shall name a day (not being less than fourteen days from the date of the notice) and a place or places on and at which such call or installment and such interest thereon at such rate not exceeding 18 percent per annum as the Directors shall determine from the day on which such call or installment ought to have been paid and expenses as aforesaid are to be paid. The notice shall also state that, in the event of non-payment at or before the time and at the place appointed, the shares in respect of which the call was made or installments is payable will be liable to be forfeited.
41. If notice not complied with shares to be forfeited. If the requirements of any such notice as aforesaid shall not be complied with, every or any share in respect of which such notice has been given may at any time thereafter before payment of all calls or installments interest, and expenses due in respect thereof, be forfeited by a resolution of the Board to that effect. Such forfeiture shall include all dividends declared or any other monies payable in respect of the forfeited shares and not actually paid before the forfeiture.
42. Notice of forfeiture to a Member. When any share shall been so forfeited notice of the forfeiture shall be given to the Member in whose name it stood immediately prior to the forfeiture, and an entry of the forfeiture, with the date thereof, shall forthwith be made in the Register of Members, but



no forfeiture shall be in any manner invalidated by any omission or neglect to give such notice or to make any such entry as aforesaid.

43. Forfeited shares to be property of the company and may be sold etc., Any shares so forfeited shall be deemed to be the property of the Company, and may be sold, reallocated or otherwise disposed off either to the original holder, thereof or to any other person, upon such terms and in such manner as the Board shall think fit.
44. Member still liable to pay money owing at time of forfeiture and interest. Any member whose shares have been forfeited shall notwithstanding the forfeiture be liable to pay and shall forthwith pay to the company on demand all monies owing upon or in respect of such shares at the time of the forfeiture, but his liability shall cease it and when the company receives payment in full of the normal amount of shares.
45. Evidence of forfeiture A declaration in writing that the declarant is a Director or Secretary of the company and that a share in the company has been duly forfeited in accordance with these Articles on a date stated in the declaration, shall be conclusive evidence of the facts therein stated as against all persons claiming to be entitled to the shares.
46. Power to annual forfeiture. The Board may, at any time before any share so forfeited shall have been sold, re-allotted or otherwise disposed off annul the forfeiture thereof upon such conditions as it thinks fit.

TRANSFER AND TRANSMISSION OF SHARES

- 47 a) Register of Transfers. The company shall keep a "Register of Transfers" and therein shall be fairly and distinctly entered particulars of every transfer or transmission of any share.
- b) Transfer Books and Register of Members when closed. The board shall alter giving not less than seven days' previous notice by advertisement in some newspaper circulating in the state of A.P. Close the Transfer Books, the Register of Members or Register of Debenture-holders at such time or times and for such period or periods, not exceeding thirty days at a time and not exceeding in the aggregate forty five days in each year.
48. Form transfer. The instrument of transfer shall be in writing and all the provisions of Section 108 of the Companies Act and of any statutory modification thereof for the time being shall be duly complied with in respect of all transfers of shares and registration thereof.
49. Transfer form to be completed and presented to the Company. The instrument of Transfer duly stamped and executed by the Transferor and the Transferee shall be delivered to the company in accordance with the provisions of the Act. The Transferor shall be deemed to be the holder of such shares until the name of the transferee shall have been entered in the Register of Members in respect thereof. Before the registration of a transfer the certificates of the shares must be delivered to the company.
50. Directors may refuse to register the transfers. Subject to the provisions of Section 111 of the Act, the board may, at its own absolute and uncontrolled discretion and without assigning any reason, decline to register or acknowledge any transfer of shares, whether fully paid or not, (notwithstanding that the proposed transferee be already a member), but in such cases it shall within two months from the date on which the instrument of transfer was lodged with the company, send to the transferee and the transferor notice of the refusal to register such transfer; provided that the registration of a transfer shall not be refused on the ground of the transferor being, either alone or jointly with any person or persons indebted to the Company on any account whatsoever except a lien.
51. Notice of application when to be given. Where, in the case of partly paid shares, an application for registration is made by the transferor, the company shall give notice of the application to the transferee in accordance with the provisions of Section 110 of the Act.
52. Death of one or more joint holders of shares. In case of the death of any one or more of the persons named in the Register of Members as the joint-holders of any shares, the survivor or survivors shall be the only persons recognized by the company as having any title to or interest in such shares but nothing herein contained shall be taken to release the estate of a deceased joint holder from any liability on shares held by him jointly with any other persons.
53. Title to shares of deceased Member. The executors or administrators or holders of a Succession Certificate or the legal representatives of a deceased member (not being one or two or more joint-holders) shall



be the only person recognized by the Company as having any title to the shares registered in the name of such Member, and the Company shall not be bound to recognize such executors or administrators or holders of a succession certificate, as the case may be, from a duly constituted Court in the Union of India; provided that in any case where the Board in its absolute discretion thinks fit, the Board may dispense with production of Probate or Letters of Administration or Succession Certificate, upon terms as to indemnify or otherwise as the board in its absolute discretion may think necessary and under Article 55 register the name of any person who claims to be absolutely entitled to the shares standing in the name of a deceased member, as a member.

54. No transfer to minor etc. No share shall in any circumstance be transferred to any minor, insolvent, or person of unsound mind.
55. If quorum not present, meeting to be dissolved or adjourned. Subject to the provisions of the Act and Articles 52 and 53 any person becoming entitled to shares in consequence of the death, lunacy, bankruptcy or insolvency of any member; or by any lawful means other than by transfer in accordance with these Articles, may, with the consent of the Board (which it shall not be under any obligation to give), upon producing such evidence that he sustains the character in respect of which he proposes to act under this article or of such title as the Board thinks sufficient, either be registered himself as the holder of the shares or elect to have some person nominated by him and approved by the Board registered as such holder; provided nevertheless, that if such person shall elect to have his nominee an instrument of transfer in accordance with the provisions herein contained, and until he does so, he shall not be freed from any liability in respect of the shares
56. Persons entitled may receive dividend without being registered as Member. A person entitled to a share by transmission shall, subject to the right of the directors to retain such dividends, or money as hereinafter provided, be entitled to receive, and may give a discharge for, any dividends or other monies payable in respect of the share.
57. Fee on transfer or transmission. No fee shall be payable to the Company, in respect of the transfer or transmission of any shares.
58. Company not liable for disregard of a notice prohibitions registrations of a transfer. The Company shall incur no liability or responsibility whatsoever in consequence of its registering or giving effect to any transfer of shares made proportion to be made by any apparent legal owner thereof (as shown or appearing in the Register of Members) to the prejudice or persons having or claiming any equitable right, title or interest to or in the said shares, notwithstanding that the Company may have had notice of such equitable, right, title or interest or notice prohibiting registration of such transfer, and may have entered such notice, or referred thereto in any book of the Company and the Company shall not be bound or required to regard or attend or give effect to any notice which may be given to it of any equitable right, title or interest or be under any liability whatsoever for refusing or neglecting so to do, though it may have been entered or referred to in some book of the company, but the company shall nevertheless be at liberty to regard and attend to any such notice and give effect thereto if the Board shall so think fit.

COPIES OF MEMORANDUM AND ARTICLE TO BE SENT TO MEMBERS

59. Copies of Memorandum and Articles of Association to be sent by the company. Copies of the Memorandum and Articles or Association of the Company and other documents referred to in Section 39 of the Act shall be sent by the Company to every member at his request within seven days of the request on payment of the sum of Rupee one for each copy.

BORROWING POWERS

60. Power to borrow. Subject to the provisions of Section 292 and 293 of the Act the Board may from time to time at its discretion by a resolution passed at a meeting of the Board, accept, deposits from members either in advance of calls or otherwise and generally raise or borrow or secure the payment of any sum or sums of money for the purposes of the company, provided, however, that where the moneys to be borrowed together with the moneys already borrowed (apart from temporary loans obtained from the Company's bankers in the ordinary course of business; exceed the aggregate of the paid up capital of the Company and its free reserves (not being reserves set apart for any specific purpose; the Board shall not borrow such moneys without the consent of the Company in general Meeting.



63. Register of Mortgages etc. to be kept. The Board shall cause a proper Register to be kept in accordance with the provisions of Section 143 of the Act of all mortgages, debentures and charges specifically affecting the property of the Company; and shall cause the requirements of Section 118, 125 and 127 to 144 (both inclusive) of the Act in that behalf to be duly complied with, so far as they fall to be complied with by the Board.

MEETINGS OF MEMBERS

65. Annual General Meeting – Annual Summary. The Company shall in each year hold an Annual General Meeting in addition to any other meetings in that year. All General Meeting sother than Annual General Meeting shall be called Extraordinary General Meetings. The First Annual General Meeting shall be held in accordance with Section 166 of the Act. Every Annual General Meeting shall be called for a time during business hours, on a day that is not a public holiday, and shall be held at the office of the Company or at some other place within the city in which the office of the Company is situated as the Board may determine and the Notices calling the Meeting shall specify it as the Annul General Meeting. Every member of the company shall be entitled to attend either in person or by proxy and the Auditor of the Company shall have the right to attend and to be heard at any General Meeting which he attend on any part of the business which concerns him as Auditor. At every Annual General Meeting of the Company there shall be laid on the table the Directors' Report and Audited Statement of Accounts, Auditors' Report (if not already incorporated in the Audited Statement of Accounts), the Proxy Register with proxies and the Register of Directors' share holdings which shall remain open and accessible during the continuance of the meeting.
66. Extraordinary General Meeting. The Board may, whenever it thinks fit, call an Extraordinary General Meeting and it shall do so upon a requisition in writing by any member or members as provided by Section 169 of the act.
67. Twenty one days notice of meeting to be given. Twenty-one days' notice at the lease of every General Meeting, Annual or Extra-ordinary and by whomsoever called specifying the day, place and hour of meeting, and the general nature of the business to be transacted thereat shall be given in the manner hereinafter provided to such persons as are under these Articles entitled to receive notice from the Company. Provided that in the case of any Annual general meeting with the consent in writing of all the members entitled to vote thereat and in case of any other meeting, with the consent of members holding not less that 95 per cent of such part of the paid-up share capital of the Company as gives a right to vote at the meeting, a meeting may be convened by a shorter notice. In the case of an Annual General Meeting, if any business other than (i) the consideration of the Accounts, Balance Sheets and reports of the Board of directors and Auditors (ii) the declaration of dividend, (iii) the appointment of Directors in place of those retiring, (iv) the appointment of, and fixing of the remuneration of, the Auditors, is to be transacted, and in the case of any other meeting in any event, there shall be annexed to the notice of the Meeting a statement setting out all material facts concerning each such item of business, including in particular the nature of the concern or interest, if any, therein of every Director, and Manager (if any) where other Company, the extent of share holding interest in the other company of every Director and the Manager, if any, of the Company shall also be set out in the statement if the extent of such share-holding interest is not less than 20 percent of the paid-up share capital of that other company. Where any item of business consists of the according of approval to any document by the meeting, the time and place where the document can be inspected shall be specified in the statement aforesaid.
68. Omission to give not to invalidate a resolution passed. The accidental omission to give any such notice as aforesaid to any of the members, or the non-receipt thereof, shall not invalidate any resolution passed at any such meeting.
69. Meeting not to transact business not mentioned in notice. No General Meeting, Annual or Extra-ordinary, shall be competent to enter upon discuss or transact any business which has not been mentioned in the notice or notices upon which it was convened.
70. Quorum at General Meeting. Five members present in person shall be a quorum for a General Meeting.
71. Body corporate deemed to be personally present. A body corporate being a member shall be deemed dot personally present if it is represented in accordance with Section 187 of the Act.



72. If quorum not present, meeting to be dissolved, or adjourned. If, at the expiration of half an hour from the time appointed for holding a meeting of the company, a quorum shall not be present, the meeting, if convened by or upon the requisition of members, shall stand dissolved, but in any other case the meeting shall stand adjourned to the same day in the next week or if that is a public holiday until the next succeeding day which is not a public holiday at the same time and place or to such other day and at such other time place in the City or town which the Office of the company is for the time being situated, as the Board may determine, and if at such adjourned meeting a quorum is not present at the expiration of half an hour form the time appointed for holding meeting, the members present shall be a quorum, and may transact the business for which the meeting was called.
73. Chairman of General Meeting. The Chairman (if any) of the Directors shall be entitled to take the chair at every general meeting, whether annual or Extra-ordinary. If there be no such Chairman or the Directors, or if at any meeting he shall not be present within fifteen minutes from the time appointed for holding such meeting or if he shall be unable or unwilling to take the chair then the members present shall elect another Director as Chairman, and if no Director be present or if all the Directors present decline to take the Chair, then the members present shall elect one of their number to be Chairman.
74. Business confined to election of Chairman whilst Chair vacant. No business shall be discussed at any General Meeting except the election of a Chairman, whilst the chair is vacant.
75. Chairman with consent may adjourn meeting. The Chairman with the consent of the Members may adjourn any meeting from time to time and from place to place but no business shall be transacted at any adjourned meeting other than the business left unfinished at the meeting which the adjournment took place.
76. Questions at General Meeting how decided. At any General meeting a resolution put to the vote of the meeting shall be decided on a show of hands, unless a poll is (before or on the declaration of the result of the show of hands) demanded as provided in Article 78 hereof.
77. Chairman's casting vote. In the case of an equality of votes, the Chairman shall both on a show of hand and at a poll (if any) have a casting vote in addition to the vote or votes to which he may be entitled as a member.
78. Demand for poll. Before or on the declaration of the result of the voting on any resolution on a show of hands, a poll may be ordered to be taken by the Chairman of the Meeting of his own motion and shall be ordered to be taken by him on a demand made in that behalf by any member or members present in person or by proxy and holding shares in the Company which confer a power to vote on the resolution not being less than one-tenth of the total voting power in respect of the resolution, or on which an aggregate sum of not less than fifty thousand rupees has been paid up. The demand for a poll may be withdrawn at any time by the person or persons who make the demand.
79. Poll to be taken if demanded. If a poll is demanded as aforesaid the same shall subject to Article 78 be taken at such time (not later than forty-eight hours form the time when the demand was made) and place within the City or town in which the office of the Company is for the time being situated, and either by open voting or by vallot, as the Chairman shall direct, and the result of the poll shall be deemed to be the resolution of the meeting at which the poll was demanded. The demand is for a poll may be withdrawn at any time by the persons or person who made the demand.
80. Scrutineers at poll. Where a poll is to be taken, the Chairman of the meeting shall appoint two scrutinees to scrutinize the votes given on the poll and to report thereon to him. One of the scrutineers so appointed shall always be a member (not being an officer or employee of the Company) present at the meeting, provided such a member is available and willing to be appointed. The Chairman shall have power at any time before the result of the poll is declared to remove a scrutineer form office and till vacancies in the office of scrutineers arising from such removal or from any other cause.
81. In what case poll taken without adjournment. Any poll duly demanded on the election of a chairman of a meeting or on any question of adjournment shall be taken at the meeting forthwith.



82. Demand for poll not prevent, transaction of other business. The demand for a poll except on the question of the election of the Chairman and of an adjournment shall not prevent the continuance of meeting for the transaction of any business other than the question on which the poll has been demanded.

VOTES OF MEMBERS

83. Members in arrears not to vote. No member shall be entitled to vote either personally or by proxy at any General Meeting or Meeting of a class of share-holders either upon a show of hands or upon a poll in respect of any shares registered in his name for which any calls or other sums presently payable by him have not been paid or in regard to which the Company has, and has exercised, any right to lien.
84. Number of votes to which Member entitled. Subject to the provisions of these Articles and without prejudice to any special privileges or restrictions as to voting for the time being attached to any class of shares for the time being forming apart of the capital of the Company, every member, not disqualified by the last preceding Article shall be entitled to be present, and to speak and vote at such meeting, and on a show of hands, every member present in person shall have one vote and upon a poll the voting right of every member present in person or by proxy shall be in proportion to his share of the paid-up equity share capital of the Company. Provided, however, if any preference shareholder be present at any meeting of the company, save as provided in clause (b) of sub-section (2) of Section 87, he shall have a right to vote only on resolutions placed before the meeting which directly affect the rights attached to his preference shares.
85. How members of unsound mind may vote. A member of unsound mind or in respect of whom an order has been made by any Court having jurisdiction in lunacy, may vote, whether on a show of hands, or on a poll, by his committee or other legal guardian, and any such committee or guardian may vote by proxy.
86. Votes of joint-members. If there be a joint registered holders of any shares, any one of such persons may vote at any meeting or may appoint another person (whether a member or not) as his proxy in respect of such shares, then one of the said persons so present whose name stand higher on the Register shall alone be entitled to speak and to vote in respect of such shares.
87. Appointment of Proxy. Every proxy (whether a member or not) shall be appointed in writing under the hand of the appointer of his attorney, or if such appointed is a corporate under the common seal of such corporation, and be signed by an officer or any attorney duly authorized by it, and any Committee or guardian may appoint such proxy. The proxy so appointed shall not have any right to speak at the meeting.
88. Proxy either for specified meeting or for a period. An instrument of proxy may appoint a proxy either for the purpose of a particular meeting specified in the instrument and any adjournment thereof or it may appoint for the purpose of every meeting of the Company, or of every meeting to be held before a date specified in the instrument and every adjournment of any such meeting.
89. No proxy except for a body corporate to vote on a show of hands. No member present only by proxy shall be entitled to vote on a show of hands, unless such member is a body corporate present by a proxy who is not himself a Member, in which case, such proxy shall have a vote on the show of hands as if he were a member.
90. Deposit of instrument of appointment. The instrument appointing a proxy shall be deposited at the office not later than forty-eight hours before the time for holding the meeting at which the person named in the instrument proposes to vote, and in default the instrument or proxy shall not be treated as valid.
91. Form of proxy. Every instrument of proxy whether for a specified meeting or otherwise, shall, as nearly as circumstances will admit, be in any of the forms set out in Schedule IX of the Act.
92. (1) Minutes of General Meeting and inspection, thereof by Members. The Company shall cause minutes of all proceedings of every General meeting to be kept by mailing within thirty days of the conclusion of every such meeting concerned, entries thereof in books kept for the purpose with their pages consecutively numbered.
- (2) Each page of every such book shall be initialized or signed and the last page of the record of proceedings of each meeting in such book shall be dated and signed by the Chairman



of the same meeting within the aforesaid period of thirty days or in the event of the death or inability of the Chairman within that period, by a Director duly authorized by the Board for the purpose.

- (3) In no case the minutes of proceedings of a meeting shall be attached to any such book as aforesaid by pasting or otherwise.
- (4) The minutes of each meeting shall contain a fair and correct summary of the proceeding thereat.
- (5) All appointments of officers made at any meeting aforesaid shall be included in the minutes of the meeting.
- (6) Nothing herein contained shall require or be deemed to require the inclusion in any such minutes of any matter which in the opinion of the Chairman of the meeting (a) is or could reasonably be regarded as defamatory of any reason or (b) is irrelevant or immaterial to the proceedings or (c) is detrimental to the interest of the Company.
- (7) Minutes of meetings shall be evidence of the proceedings therein.

DIVIDENDS

135.

- 1) The Company in General Meeting may declare dividends but no dividends shall executed the recommended by the Board.
- 2) The Company can declare or pay dividend for any financial year only out of the profits of the Company after providing for depreciation in accordance with Section 205 (2) of the Act and after transferring to the General Reserve Account the prescribed percentage of profits of that year.
- 3) In the event of inadequacy or absence of profits for purpose of declaration of dividend the Company may transfer any amount from its accumulated profits of the earlier years provided the amount so transferred is in accordance with the rules made by the Central Government for that purpose. That Company may transfer more amount also with the prior approval of the Central Government.

136. Interim dividend.

The Board may, from time to time, pay to the Members such interim dividends as in their judgment the position of the Company justifies.

137. Capital paid up in advance at interest not to earn dividend.

Where capital is paid in advance of calls, such capital may carry interest but shall not in respect thereof, confer a right to dividend or participate in profits.

138. Dividends in proportion to amount paid-up.

All dividends shall be apportioned and paid proportionately to the amounts paid or credited as paid on the shares during any portion or portions of the period in respect of which the dividend is paid; but if any share is issued on terms providing that it shall rank for dividend as from a particular date, such share shall rank for dividend accordingly.

139. Retention of dividend in certain cases.

The board may retain the dividends payable upon shares in respect of which any person is, under Article 55 receipts for all dividends or bonus and payment son account of dividends or bonus or other moneys payable in respect of such shares.

140. Dividend etc. to joint holders.

Anyone of several persons who are registered as the joint-holders of any share may give effectual receipts for all dividends or bonus and apyaments on account of dividends or bonus or other moneys payable in respect of such shares.

141. No member to receive dividend whilst indebted to the company and company's right of reimbursement thereof.

No member shall be entitled to receive a payment of any interest or dividend in respect of his share or shares, whilst any money may be due or owing from him to the company in respect of such share or shares or otherwise however, either alone or jointly with any other person or persons; and the Board may deduct from the interest or dividend payable to any member all sums of money so due from him to the company.

142. Transfer of shares must be registered.

A transfer of shares shall not pass the right to any dividend declared thereon before the registration of the transfer.



143. Dividends how remitted. Unless otherwise directed any dividend may be paid by cheque or warrant or by a pay slip or receipt having the force of a cheque or warrant sent through the post to the registered address of the Member or person entitled or in case of joint holders to that one of them first named in the Register of Members in respect of joint holding. The company shall not be liable or responsible for any cheque or warrant or pay-slip or receipt lost in transmission or for any dividend lost to the Member or person entitled thereto by the forged endorsement of any cheque or warrant or the forged signature on any pay-slip or receipt or the fraudulent recovery of the dividend by any other means. If two or more persons are registered as joint-holders of any share or shares any one of them can give effectual receipts for any monies payable in respect thereof. Several executors or administrators of a deceased member in whose sole name any share stands, shall for the purposes of this clause be deemed to be joint-holders thereof.
144. a) If the company has declared a dividend but which has not been paid or a dividend warrant in respect thereof has not been paid within 30 days from the date of declaration to any shareholder entitled to the payment of the dividend the company shall within 7 days from the date of the expiry of the said period of 30 days open a special account in that behalf in any scheduled bank called "the unpaid dividend account of "XL TELECOM LIMITED".
- b) Any money transferred to the unpaid dividend account of the Company which remains unpaid or unclaimed for a period of 7 years from the date of such transfer, shall be transferred by the Company to a Fund established under Section 205C of the Act and no claim shall lie on the amount transferred to the said Fund.
145. No interest on dividends. Subject to the provisions of the Act no unpaid dividend shall bear interest as against the company, and no unclaimed dividend shall be forfeited by the Board before the claim thereto becomes barred by law.
146. Right to dividend, rights shares and bonus shares to be held in abeyance pending registration of transfer. Where an instrument of transfer of shares has been delivered to the company for registration and the transfer of such shares has not been registered by the company, it shall, notwithstanding anything contained in these Articles -
- a) Transfer the dividend in relation to such shares to the special account referred to in Article 144 unless the company is authorized by the registered holder of such shares in writing to pay such dividends to the transferee specified in such instrument of transfer and
- b) Keep in abeyance in relation to such shares any offer of right shares under Article 13 and any issue of fully paid bonus shares in pursuance of Article 147 hereof.
147. a) The company in General Meeting may resolve that any monies, investments, or other assets forming part of the undivided profits of the company or standing to the credit of the General Reserve or and Reserve Fund or any other Fund of the company, the Capital Redemption Reserve Account or in the hands of the company and available for dividend, or representing premiums received on the issue of shares and standing to the credit of the Share Premium Account, be capitalized and distributed amongst such of the shareholders of any class shareholders as would be entitled to receive the same if distributed by way of dividend in accordance with their respective rights and interests and in proportion to the amount of capital paid up on shares held by them respectively, on the footing that they become entitled thereto as capital and that all or any part of such capitalized fund be applied on behalf of such shareholders in paying up in full either at part or at such premium as the resolution may provide, any unissued shares of the company or debentures of the company which shall be distributed accordingly, or in towards payments of the whole or part of the uncalled liability on any issued shares and that such distribution or payment shall be accepted by such shareholders in full satisfaction of their interest in the said capitalized sum. Provided that a Share Premium Account and a Capital Redemption Reserve Account may, for the purposes of this Article only be applied in the paying up of unissued shares to be issued to Members of the Company as fully paid bonus shares.
- b) A General Meeting may resolve that any surplus moneys arising from the realization of any capital assets of the company, or any investments representing the same, or any



other undistributed profits of the company not subject to charge for income-tax be distributed among the members on the footing that they receive the same as capital.

- c) For the purpose of giving effect to resolution under the preceeding paragraphs of this article the Board may settle any difficulty which may arise in regard to the distribution as it thinks expedient and in particular may issue fractional certificates, and may fix the value for distribution of any specific assets, and may determine that such cash payment shall be made to any members upon the footing of the value so fixed or that fraction of less than Rs. 100/- may be disregarded in order to adjust the rights of all parties, and may vest any such cash or specific assets in trustees upon such trusts for the person entitled to the dividend or capitalized fund as may seem expedient to the Board. Where requisite, a proper contract shall be delivered to the Registrar for registration in accordance with Section 75 of the Companies Act, 1956 and the Board may appoint any person to sign such contract on behalf of the persons entitled to the dividend or capitalized fund, and such appointment shall be effective.

ACCOUNTS

148. a) The company shall keep at its office or at such other place in India as the Board thinks proper Books of Account in accordance with Section 209 of the Act with respect to –
- (i) All sums of money received and expended by the company and the matters in respect of which the receipts and expenditure takes place ;
 - (ii) All sales and purchases of goods by the company ;
 - (iii) The assets and liabilities of the company.
- b) Where the board decides to keep all or any of the books of account at any place other than the office of the company, the company shall within seven days of the decision file with the Registrar a notice in writing giving the full address of that other place.
- c) The company shall preserve in good order the Books of Account relating to a period of not less than eight years preceding the current year together with the vouchers relevant to any entry in such books of account.
- d) Where the company has a branch office, whether in or outside India, the company shall be deemed to have complied with this Article if proper books of Account relating to the transactions effected at the branch office are kept at the branch office and proper summarized returns, made up to dates at intervals of not more than three months, are sent by the branch office to the company at this office or other place in India at which the company's Books of Accounts are kept as aforesaid.
- e) The Books of Account shall give a true and fair view of the state of the affairs of the company or branch office, as the case may be, and explain its transactions. The books of account and other books papers shall be open to inspection by any Director during business hours.
149. A copy of every such profit and loss account and balance sheet (including the Auditor's Report and every other document required by law to be annexed or attached to the Balance sheet), shall at least twenty-one days before the meeting at which the same to be laid before the members, be sent to the members of the company, to every trustee for the holders of any debentures issued by the company (whether such member or trustee is or is not entitled to have notices of general meetings of the company sent to him), and to all persons other than such members or trustees, being persons so entitled. Provided that the documents aforesaid shall not be required to be sent if the copies thereof are made available for inspection at the company's Registered Office during working hours for a period of twenty-one days before the date of the aforesaid meeting and a statement containing the salient features of such documents in the prescribed form or copies of the documents is sent to every member of the company and to every trustee for the holders of any debentures issued by the company, not less than twenty-one days before the date of the said meeting.



150. Any member or holder of debentures of the company and any person from whom the company has accepted a sum of money by way of deposit, shall on demand, be entitled to be furnished, free of cost, with a copy of the last balance sheet of the company and for every document required bylaw to be annexed or attached thereto, including the profit and loss account and the Auditor's Report.

DOCUMENTS AND NOTICES

155. 1) A document or notice may be served or given by the company o any member either personally or by sending it by post to him to his registered address or (if he has no registered address in India) to the address, if any, in India supplied by him to the company for serving documents or notices on him.
- 2) Service of documents or notices on members by company. Where a document or notice is sent by post, service of the document or notice shall be deemed to be effected by properly addressing, prepaying and posting a letter containing the document or notice, provided that where a member has intimated to the company in advance that documents or notices should be sent to him under certificate of posting or by registered post with or without acknowledgement due and has deposited with the company a sum sufficient to defray the expenses of doing so; servicing of the document or notice shall not be deemed to be effected unless it is sent in the manner intimated by the member and, such servicing shall be deemed to have been effected in the case of a Notice of a meeting, at the expiration of forty-eight hours after the letter containing the document or notice is posted and in any other case, at the time at which the letter would be delivered in the ordinary course of post.
156. By advertisement. A document or notice advertised in a newspaper circulating in their neighbourhood office shall be deemed to be duly served or sent on the day on which the advertisement appears, to every member who has no registered address in India and has not supplied to the company an address within India for the serving documents, on the sending of notices to him.
157. On joint-holders. A document or notice may be served or given by the company on or to the joint holders of a share by serving or giving the document or notice on or to the joint-holder named first in the Register of Members in respect of the share.
158. A document or notice may be served or given by the company on or to the persons entitled to a share in consequence of the death or insolvency of a member by sending it through the post in a prepaid letter addressed to them by name or by the titled or representatives of the deceased, or assignee of the insolvent or by any like description, at the address (if any) in India supplied for the purpose by the persons claiming to be entitled, or (until such an address has been so supplied) by serving the document or notice in any manner in which the same might have been given if the death or insolvency had not occurred.
159. To whom documents or notice must be served or given. Documents or notices of every General Meeting shall be served or given in same manner hereinbefore authorized on or to (a) every member, (b) every person entitled to a share in consequence of the death or insolvency of a member, and (c) the Auditor or Auditors for the time being of the company.
- 160 To whom documents or notice must be served or given. Every person who, by operation of law, transfer or other means whatsoever, shall become entitled to any share, shall be bound by every document or notice in respect of such shares, which previous to his name and address being entered on the Register of members, shall have been duly served on or given to the person who he derives his titles to such share.
161. Members bound by documents or notices served or given to previous holders. Every person who, by operation of law, transfer or other means whatsoever, shall become entitled to any share, shall be bound by every document or notice in respect of such shares, which previous to his name and address being entered on the Register of members, shall have been duly served on or given to the person from whom he derives his title to such share.
161. Document or notice by company and signature thereto. Any documents or notice to be served or given by the company may be signed by a Director or the Secretary or some person duly authorized by the Board of Directors for such purpose and the signature thereto may be written, printed to lithographed.
162. Service of the document or notice by Member. All documents or notices to be served or given by members on or to the company or any officer thereof shall be served or given by sending it to the company or officer at the office by post under a certificate of posting or by registered post, or by leaving it at the office.



SECTION XII

MATERIAL CONTRACTS AND DOCUMENTS FOR INSPECTION

The following contracts (not being contracts entered into in the ordinary course of business carried on by the Company or contracts entered into more than two years before the date of filing of this Red Herring Prospectus) which are or may be deemed material have been entered or to be entered into by the Company. These contracts, copies of which have been attached to the copy of the Red Herring Prospectus have been delivered to the Registrar of Companies, Andhra Pradesh at Hyderabad for registration and also the documents for inspection referred to hereunder, may be inspected at the Corporate Office of our Company located at 335, Chandralok Complex, S.D. Road, Secunderabad – 500 003 from 10.00 a.m. to 4.00 p.m. on working days from the date of filing of this Red Herring Prospectus until the Bid Closing Date / Issue Closing Date of this Issue.

Material Contracts for Inspection

1. Letters of Engagement dated March 1, 2006 from Anand Rathi Securities Private Limited and Centrum Capital Limited offering their services to act as BRLMS and Company's acceptance thereto.
2. Memorandum of Understanding dated May 10th 2006 between the Company and the BRLMS to this Issue.
3. Memorandum of Understanding dated April 13th 2006 between the Company and Bighshare Services Private Limited as Registrars.
4. Escrow Agreement dated November 21, 2006 between the Company, the BRLMS, Escrow Collection Bank and the Registrar to this Issue.
5. Underwriting Agreement dated [●] between the Company, BRLMS and the Syndicate Member.
6. Syndicate Agreement dated November 21, 2006 between the Company, BRLMS and the Syndicate Member.

Material Documents for Inspection

1. Certified true copies of the Memorandum and Articles of Association of the Company, as amended from time to time.
2. Second Certificate of Incorporation of the Company dated 20th February, 2002 obtained from the Registrar of Companies, Andhra Pradesh
3. Fresh Certificate of Incorporation consequent to conversion of the Company from Private Limited to Public Limited dated December 31st, 1990.
4. Copy of the resolution passed at the meeting of the Board of Directors held on January 27th, 2006 approving the Public Issue.
5. Copy of Resolution of the Members of the Company passed at the Annual General Meeting held on February 23rd 2006 pursuant to Section 81(1A) of the Companies Act.
6. Copies of the Annual Reports of the Company for the years ended June 30, 2001; June 30, 2002; March June 30, 2003; June 30, 2004, June 30, 2005 and June 30, 2006.
7. Copy of the Statement of Tax Benefits report dated November 5th 2006 issued by the Statutory Auditors, M/s. Satyanarayana & Co., Chartered Accountants.
8. Copies of Annual Reports of the Associate Company for the year ended March 31, 2004, March 31, 2003 and March 31, 2002.
9. Reports of the Statutory Auditors, M/s. Satyanarayana & Co, Chartered Accountants dated November 6th, 2006 as per Indian GAAP and included in this Red Herring Prospectus.
10. Consents letters of the (a) Directors, (b) Company Secretary and Compliance Officer, (c) Book Running Lead Managers to this Issue, (d) Legal Advisors, (e) Bankers to the Company, (f) Bankers to this Issue and (g) Registrars to this Issue, Escrow Collection Bank(s), Syndicate members to include their names in the Red Herring Prospectus to act in their respective capacities.
11. Consent letters dated April 5th, 2006 from M/s. Satyanarayana & Co, Chartered Accountants, for inclusion of their names as the Statutory Auditors and of their reports on accounts in the form and context in which they appear in the Red Herring Prospectus.
12. Certified true copies of the resolution for the appointment of Managing Director and Wholetime Directors.



13. Share Subscription and Shareholders Agreement dated 2nd May, 2006 between M/s. XL Telecom Limited, Mr. Dinesh Kumar, M/s. Snehlata Lal Family Welfare Trust and M/s. 2i Capital PCC.
14. General Power of Attorney (s) dated 1st February, 2006 & 28th March, 2006 executed by Directors of the Company in favour of Mr. Dinesh Kumar for signing and making necessary changes to the Red Herring Prospectus.
15. Memorandum of Understanding dated 31st March, 2003 as amended from the Kyocera Corporation, Japan for manufacture and deal in the CDMA handsets in India.
16. Title deeds for Mallapur plant bearing Shed No. 30,31,32, IDA, Mallapur, Hyderabad – 500 076
17. Title deeds for cherlapally plant bearing Plot No. 198/A & 198B IDA, Cherlapally, Hyderabad – 500 051
18. Lease deed dated 22nd March, 2004 for Ethanol Plant located at Nanded in the state of Maharashtra executed with Maharashtra Industrial Development Corporation for lease of Plot Nos. B. 8-8,9,20, 21 & B – 10, 18, 19. M.I.D.C, Kushnoor Industrial Area, Nanded, Maharashtra.
19. Purchase order copies received from Oil Companies i.e. HPCL, BPCL and IOCL for supply of Ethanol
20. Purchase order received from BSNL for supply of FWP's worth Rs. 96.60 Crores
21. MOU dated September 15, 2005 with Axsetel Inc., California for manufacture and deal in the FWP with CDMA technology in Indian Market.
22. Exclusive Distribution Contract with Forta Import-Export, SL Spain for supply of Solar Photovoltaic Modules.
23. Understanding with Mr. Stefan Giselbrecht Austria for development of Telecom Power Plant ranging from 25-200 A.
24. Tripartite agreement dated October 06, 2005 between the NSDL, XL Telecom Limited and Bighshare Services Private Limited, Registrar to the Issue
25. Tripartite agreement dated September 19, 2005 between the CDSL, XL Telecom Limited and Bighshare Services Private Limited, Registrar to the Issue.
26. Licence Agreement with RXS Shrumftechnik Garnituren GmbH 19th October, 1987 with amendment thereto.
27. Purchase Orders Placed by the Company for Switch Mode Transmission Lines
28. Purchase Orders Placed by the Company for Solar Photovoltaic Systems
29. Resolution of the Meeting of the Board of Directors held on 1st March, 2006 for the formation of the Company's Audit Committee, Investor Grievances Committee and Remuneration Committee.
30. Due diligence Certificate dated May 11, 2006 to SEBI from Anand Rathi Securities Private Limited and Centrum Capital Limited, the BRLMs to this Issue.
31. Legal Advisor's Due Diligence Certificate dated May 11, 2006.
32. Listing application dated November 14, 2006 filed with the BSE and the NSE.
33. In-principle listing approvals dated July 3, 2006 from BSE and July 24, 2006 and November 3, 2006 from NSE.
34. SEBI observation letter no. CFD/DIL/ISSUES/V/79212/2006 dated November 2, 2006

Any of the contracts or documents mentioned in this Red Herring Prospectus may be amended or modified at any time if so required in the interest of the Company or if required by the other parties, without reference to the shareholders subject to compliance of the provisions contained in the Companies Act and other relevant statutes.



DECLARATION

We, the Directors of our Company, hereby declare that, all the relevant provisions of the Companies Act, 1956, and the guidelines issued by the Government of India or the guidelines issued by the Securities and Exchange Board of India, as the case may be, have been complied with and no statement made in this Red Herring Prospectus is contrary to the provisions of the Companies Act, 1956, the Securities and Exchange Board of India Act, 1992 or rules made there under or guidelines issued, as the case may be. We further certify that all the disclosures and statements made in this Red Herring Prospectus are true and correct.

SIGNED BY ALL THE DIRECTORS OF XL TELECOM LIMITED

(Dr. R. Srinivasan)*
Chairman

(Dinesh Kumar)
Managing Director

(K. Vasudeva Rao)
Executive Director

(Aneesh Mittal)
Whole-Time Director

(Pramod Kumar Jain)
Whole-Time Director

(Ritu Lal Kumar)
Non-Executive Director

(Rajiv Garg)*
Independent Director

(Ashok Kumar Goyal)*
Independent Director

(Wolfgang Knop)*
Independent Director

(V.Visweswara Rao)
Sr. Vice President (Finance & Corporate)

Ch. Bhavani
Company Secretary &
Compliance Officer

* signed through Specific Power of Attorney holder Mr. Dinesh Kumar, Managing Director

Date: November 21, 2006

Place: Secundrabad



THIS PAGE IS INTENTIONALLY LEFT BLANK



THIS PAGE IS INTENTIONALLY LEFT BLANK



THIS PAGE IS INTENTIONALLY LEFT BLANK